

This document downloaded from
vulcanhammer.net vulcanhammer.info
Chet Aero Marine



Don't forget to visit our companion site
<http://www.vulcanhammer.org>

Use subject to the terms and conditions of the respective websites.

Bridge Scour and Stream Instability Countermeasures: Experience, Selection, and Design Guidance-Third Edition

Volume 1

Bridge Scour and Stream Instability Countermeasures
Experience, Selection, and Design Guidance
Third Edition
Volume 1

TABLE OF CONTENTS

LIST OF FIGURES.....	vii
LIST OF TABLES.....	xi
DESIGN GUIDELINES (Volume 2).....	xiii
ACKNOWLEDGMENTS AND DISCLAIMER.....	xv
GLOSSARY.....	xvii
CHAPTER 1. INTRODUCTION.....	1.1
1.1 PURPOSE.....	1.1
1.2 BACKGROUND.....	1.1
1.3 MANUAL ORGANIZATION.....	1.2
1.4 COMPREHENSIVE ANALYSIS.....	1.3
1.5 PLAN OF ACTION.....	1.5
1.6 DUAL SYSTEM OF UNITS.....	1.6
CHAPTER 2. PLAN OF ACTION AND THE COUNTERMEASURES MATRIX.....	2.1
2.1 STRATEGIES FOR PROTECTING SCOUR CRITICAL BRIDGES.....	2.1
2.1.1 Technical Advisories.....	2.1
2.1.2 Additional Guidance and Requirements.....	2.2
2.1.3 Management Strategies for a Plan of Action.....	2.2
2.1.4 Inspection Strategies in a Plan of Action.....	2.3
2.1.5 Closure Instructions.....	2.4
2.1.6 Countermeasure Alternatives and Schedule.....	2.5
2.1.7 Other Information Necessary in a Plan of Action.....	2.5
2.1.8 Development and Implementation of a POA.....	2.5
2.2 STANDARD TEMPLATE FOR A PLAN OF ACTION.....	2.6
2.2.1 Overview.....	2.6
2.2.2 Executive Summary.....	2.7
2.3 THE COUNTERMEASURE MATRIX.....	2.7
2.4 COUNTERMEASURE GROUPS.....	2.8
2.4.1 Group 1. Hydraulic Countermeasures.....	2.8
2.4.2 Group 2. Structural Countermeasures.....	2.13
2.4.3 Group 3. Biotechnical Countermeasures.....	2.13
2.4.4 Group 4. Monitoring.....	2.14

2.5	COUNTERMEASURE CHARACTERISTICS.....	2.15
2.5.1	Functional Applications.....	2.15
2.5.2	Suitable River Environment	2.16
2.5.3	Maintenance.....	2.16
2.5.4	Installation/Experience by State Departments of Transportation	2.17
2.5.5	Design Guideline Reference.....	2.17
2.5.6	Summary.....	2.17
CHAPTER 3. CONSIDERATIONS FOR SELECTING COUNTERMEASURES.....		3.1
3.1	INTRODUCTION.....	3.1
3.2	CRITERIA FOR THE SELECTION OF COUNTERMEASURES.....	3.2
3.2.1	Erosion Mechanism	3.2
3.2.2	Stream Characteristics	3.2
3.2.3	Construction and Maintenance Requirements	3.4
3.2.4	Vandalism	3.4
3.2.5	Countermeasure Selection Based on Cost.....	3.4
3.2.6	Countermeasure Selection Based on Risk	3.8
3.3	COUNTERMEASURES FOR MEANDER MIGRATION.....	3.9
3.4	COUNTERMEASURES FOR CHANNEL BRAIDING AND ANABRANCHING.....	3.11
3.5	COUNTERMEASURES FOR DEGRADATION AND AGGRADATION.....	3.12
3.5.1	Countermeasures to Control Degradation	3.12
3.5.2	Countermeasures to Control Aggradation	3.13
3.6	SELECTION OF COUNTERMEASURES FOR SCOUR AT BRIDGES	3.14
3.6.1	Countermeasures for Contraction Scour	3.15
3.6.2	Countermeasures for Local Scour	3.16
3.6.3	Monitoring	3.18
CHAPTER 4. COUNTERMEASURE DESIGN CONCEPTS.....		4.1
4.1	COUNTERMEASURE DESIGN APPROACH.....	4.1
4.1.1	Investment in Countermeasures.....	4.1
4.1.2	Service Life and Safety.....	4.1
4.1.3	Design Approach.....	4.2
4.2	ENVIRONMENTAL PERMITTING.....	4.3
4.3	HYDRAULIC ANALYSIS	4.4
4.3.1	Overview	4.4
4.3.2	Physical Models.....	4.4
4.3.3	Scour at Transverse Structures	4.6
4.3.4	Scour at Longitudinal Structures.....	4.7
4.3.5	Scour at Protected Bendways	4.10
4.3.6	Hydraulic Stress on a Bendway.....	4.11

CHAPTER 5. RIPRAP DESIGN, FILTERS, FAILURE MODES, AND ALTERNATIVES	5.1
5.1 OVERVIEW	5.1
5.2 RIPRAP DESIGN	5.2
5.2.1 Introduction	5.2
5.2.2 Riprap Revetment	5.2
5.2.3 Riprap for Bridge Piers	5.3
5.2.4 Riprap for Bridge Abutments	5.4
5.2.5 Riprap Protection for Countermeasures	5.4
5.2.6 Riprap for Special Applications	5.4
5.2.7 Termination Details	5.5
5.2.8 Riprap Size, Shape, and Gradation	5.5
5.3 FILTER REQUIREMENTS	5.7
5.3.1 Overview	5.7
5.3.2 Placing Geotextiles Under Water	5.8
5.4 RIPRAP FAILURE MODES	5.10
5.4.1 Riprap Revetment Failure Modes	5.12
5.4.2 Pier Riprap Failure Modes	5.17
5.4.3 Pier Riprap Failure Modes – Schoharie Creek Case Study	5.18
5.5 RIPRAP INSPECTION GUIDANCE	5.21
5.5.1 General	5.21
5.5.2 Guidance for Recording Riprap Condition	5.22
5.5.3 Performance Evaluation	5.22
5.6 GROUTED AND PARTIALLY GROUTED RIPRAP	5.22
5.7 CONCRETE ARMOR UNITS	5.25
CHAPTER 6. BIOTECHNICAL ENGINEERING	6.1
6.1 OVERVIEW	6.1
6.2 CURRENT PRACTICE	6.1
6.3 GENERAL CONCEPTS	6.2
6.4 ADVANTAGES AND LIMITATIONS OF BIOTECHNICAL ENGINEERING	6.3
6.5 DESIGN CONSIDERATIONS FOR BIOTECHNICAL COUNTERMEASURES	6.4
6.6 COMMONLY USED VEGETATIVE METHODS	6.6
6.7 ENVIRONMENTAL CONSIDERATIONS AND BENEFITS	6.6
6.8 APPLICATION GUIDANCE FOR BIOTECHNICAL COUNTERMEASURES	6.10
6.8.1 Streambank Zones	6.10
6.8.2 Biotechnical Engineering Treatments	6.11
6.9 SUMMARY	6.13

CHAPTER 7. COUNTERMEASURE DESIGN GUIDELINES	7.1
7.1 INTRODUCTION.....	7.1
7.2 DESIGN GUIDELINES.....	7.2
7.2.1 Countermeasures for Stream Instability.....	7.2
7.2.2 Countermeasures for Streambank and Roadway Embankment Protection	7.2
7.2.3 Countermeasures for Bridge Pier Protection	7.3
7.2.4 Countermeasures for Abutment Protection.....	7.4
7.2.5 Filter Design	7.4
7.2.6 Special Applications	7.4
CHAPTER 8. OTHER COUNTERMEASURES AND CASE HISTORIES OF PERFORMANCE	8.1
8.1 INTRODUCTION.....	8.1
8.2 HARDPOINTS.....	8.1
8.3 RETARDER STRUCTURES	8.1
8.3.1 Jacks and Tetrahedrons.....	8.2
8.3.2 Fence Retarder Structures	8.4
8.3.3 Timber Pile	8.4
8.3.4 Wood Fence.....	8.4
8.4 LONGITUDINAL DIKES	8.5
8.4.1 Earth or Rock Embankments.....	8.5
8.4.2 Rock Toe-Dikes.....	8.7
8.4.3 Crib Dikes.....	8.8
8.4.4 Bulkheads	8.8
8.5 CHANNEL RELOCATION	8.11
8.6 CASE HISTORIES OF COUNTERMEASURE PERFORMANCE	8.13
8.6.1 Flexible Revetment.....	8.13
8.6.2 Rigid Revetments	8.15
8.6.3 Bulkheads	8.16
8.6.4 Spurs.....	8.16
8.6.5 Retardance Structures.....	8.17
8.6.6 Dikes	8.17
8.6.7 Guide Banks.....	8.17
8.6.8 Check Dams.....	8.18
8.6.9 Jack or Tetrahedron Fields.....	8.19
8.6.10 Special Devices for Protection of Piers.....	8.19
8.6.11 Channel Alterations	8.20
8.6.12 Modification of Bridge Length and Relief Structures	8.20
8.6.13 Investment in Countermeasures.....	8.20
CHAPTER 9. SCOUR MONITORING AND INSTRUMENTATION.....	9.1
9.1 INTRODUCTION.....	9.1
9.2 PORTABLE INSTRUMENTATION	9.2

9.2.1	Components of a Portable Instrument System	9.2
9.2.2	Instrument for Making the Measurement	9.2
9.2.3	System for Deploying the Instrument.....	9.7
9.2.4	Positioning Information.....	9.10
9.2.5	Data Storage Devices.....	9.11
9.3	FIXED INSTRUMENTATION.....	9.11
9.3.1	NCHRP Project 21-3	9.11
9.3.2	Scour Measurement	9.12
9.3.3	Summary of NCHRP Project 21-3 Results	9.13
9.3.4	Operational Fixed Instrument Systems.....	9.14
9.3.5	NCHRP Project 20-5	9.22
9.3.6	Application Guidelines	9.23
9.4	SELECTING INSTRUMENTATION	9.24
9.4.1	Portable Instruments	9.25
9.4.2	Fixed Instruments.....	9.26
9.5	FIXED INSTRUMENT CASE HISTORIES.....	9.30
9.5.1	Introduction	9.30
9.5.2	Typical Field Installations.....	9.30
CHAPTER 10.	REFERENCES	10.1
APPENDIX A –	Metric System, Conversion Factors, and Water Properties	A.1
APPENDIX B –	Standard Template for a Plan of Action.....	B.1
APPENDIX C –	Pier Scour Countermeasure Selection Methodology	C.1
APPENDIX D –	Riprap Inspection Recording Guidance.....	D.1

(page intentionally left blank)

LIST OF FIGURES

Figure 1.1	Flow chart for scour and stream stability analysis and evaluation.....	1.4
Figure 3.1	Risk-based approach using NBI data	3.8
Figure 3.2	Comparison of channel bend cross sections for natural conditions and for stabilized bend	3.10
Figure 3.3	Meander migration in a natural channel and a channel with stabilized bend	3.11
Figure 3.4	Typical guide bank layout	3.17
Figure 4.1	BAW laboratory, Karlsruhe, Germany, pier scour model of railway bridge over Rhine River near Mannheim	4.6
Figure 4.2	Scour along a vertical wall as a function of unconstrained valley width	4.9
Figure 4.3	Definition sketch of width and mean water depth at the crossing upstream of the bend and maximum water depth in the bend	4.11
Figure 4.4	Shear stress multiplier K_b for bends	4.12
Figure 5.1	Riprap shape described by three axes	5.5
Figure 5.2	Close-up photo of SandMat™ geocomposite blanket	5.9
Figure 5.3	SandMat™ geocomposite blanket being unrolled	5.9
Figure 5.4	Sand-filled geotextile containers.....	5.10
Figure 5.5	Filling 1.0 metric tonne geotextile container with sand.....	5.11
Figure 5.6	Handling a 1.0 metric tonne sand-filled geotextile container.....	5.11
Figure 5.7	Two hundred lb (91 kg) sand-filled geotextile containers.....	5.12
Figure 5.8	Riprap failure by particle erosion	5.12
Figure 5.9	Damaged riprap on left bank of Pinole Creek at Pinole, CA	5.13
Figure 5.10	Riprap failure by translational slide	5.14
Figure 5.11	Riprap on Cosumnes River at Site 2 near Sloughouse, CA	5.14
Figure 5.12	Riprap failure by modified slump	5.15
Figure 5.13	Riprap on Cosumnes River at Site 3 near Sloughouse, CA	5.15

Figure 5.14	Riprap failure due to slump.....	5.16
Figure 5.15	Riprap on left bank Consumnes River at Site 1 near Sloughhouse, CA.....	5.16
Figure 5.16	South elevation – Schoharie Creek Bridge showing key structural features and a schematic geological section	5.18
Figure 5.17	Pier scour holes at Schoharie Creek Bridge in 1987	5.19
Figure 5.18	Photograph of riprap at pier 2, October 1956	5.20
Figure 5.19	Photograph of riprap at pier 2, August 1977	5.20
Figure 5.20	Close-up view of partially grouted riprap.....	5.24
Figure 5.21	"Conglomerate" of partially grouted riprap	5.24
Figure 5.22	Concrete armor units.....	5.25
Figure 5.23	Laboratory study of Toskanes for pier scour protection	5.28
Figure 5.24	Installation of A-Jacks® modular units installed by Kentucky DOT	5.28
Figure 6.1	Details of brush mattress technique with stone toe protection	6.5
Figure 6.2	Details of root wad and boulder revetment technique.....	6.5
Figure 6.3	Vegetated riprap – willow bundle method	6.7
Figure 6.4	Vegetated riprap – bent pole method	6.7
Figure 6.5	Vegetated riprap – brush layering with pole planting	6.8
Figure 6.6	Vegetated riprap – construction techniques	6.8
Figure 6.7	Vegetated riprap with joint planting.....	6.9
Figure 6.8	Bank zones defined for slope protection.....	6.11
Figure 8.1	Perspective view of hardpoint installation with section detail	8.2
Figure 8.2	Typical tetrahedron design	8.3
Figure 8.3	Typical jack unit.....	8.3
Figure 8.4	Retarder field schematic.....	8.4
Figure 8.5	Timber pile bent retarder structure	8.5
Figure 8.6	Typical wood fence retarder structure	8.6
Figure 8.7	Light double row wire fence retarder structure.....	8.6

Figure 8.8	Heavy timber-pile and wire fence retarder structures	8.7
Figure 8.9	Typical longitudinal rock toe-dike geometries	8.9
Figure 8.10	Longitudinal rock toe-dike tiebacks.....	8.9
Figure 8.11	Timber pile, wire mesh crib dike with tiebacks	8.10
Figure 8.12	Anchorage schemes for a sheetpile bulkhead	8.10
Figure 8.13	Encroachments on meandering streams	8.11
Figure 9.1	Sounding pole measurement.....	9.4
Figure 9.2	Lead-line sounding weight.....	9.4
Figure 9.3	Portable sonar in use	9.5
Figure 9.4	Kneeboard float.....	9.5
Figure 9.5	Pontoon float.....	9.6
Figure 9.6	AIDI system.....	9.6
Figure 9.7	FHWA articulated arm in use	9.8
Figure 9.8	NCHRP 21-3 articulated arm truck	9.8
Figure 9.9	Sonar instrument deployed from articulated arm truck	9.9
Figure 9.10	Unmanned, remote control boat	9.10
Figure 9.11	Master station with data logger for use with any of the fixed instruments	9.14
Figure 9.12	Above-water serviceable low-cost fathometer system	9.15
Figure 9.13	Sonar scour monitor installation including remote station	9.16
Figure 9.14	Manual read out magnetic sliding collar device	9.17
Figure 9.15	Automated read out magnetic sliding collar system.....	9.18
Figure 9.16	Detail of magnetic sliding collar on the streambed.....	9.19
Figure 9.17	Float-out devices prior to installation	9.19
Figure 9.18	Tilt meter on California bridge	9.20
Figure 9.19	Detail of tilt meter	9.20
Figure 9.20	Time domain reflectometry probe.....	9.21

Figure 9.21	Brisco Monitor sounding rods installed at a bridge pier in New York.....	9.21
Figure 9.22	Active streambed scour monitoring locations in Alaska	9.31
Figure 9.23	Oblique aerial photograph of the Knik River Old Glenn Highway.....	9.32
Figure 9.24	Conduit to sonar scour monitor at Wantagh Parkway over Goose Creek	9.33
Figure 9.25	Solar panel, remote station and (inset) conduit to sonar monitor	9.34
Figure 9.26	Adjustable stainless steel sonar mounting bracket	9.34
Figure 9.27	Installation of a sonar scour monitor on Salinas River Bridge.....	9.35
Figure 9.28	Close-up of sonar scour monitor on Salinas River Bridge.....	9.36
Figure 9.29	CALTRANS drilling with hollow stem auger for installation of float out devices at Salinas River Bridge	9.37
Figure 9.30	Installation of float out device on Salinas River Bridge	9.37
Figure 9.31	Typical instrument shelter with data logger, cell-phone telemetry.....	9.38
Figure 9.32	Installation of a float out device by Nevada DOT to monitor riprap	9.38

LIST OF TABLES

Table 1.1	Commonly Used Engineering Terms in SI and English Units	1.6
Table 2.1	Stream Instability and Bridge Scour Countermeasures Matrix	2.9
Table 5.1	Minimum and Maximum Allowable Particle Size in Inches	5.7
Table 5.2	Minimum and Maximum Allowable Particle Weight in Pounds	5.7
Table 9.1	Instrumentation Summary by Category	9.25
Table 9.2	Portable Instrumentation Summary	9.25
Table 9.3	Positioning System Summary	9.25
Table 9.4	Estimated Cost Information for Portable Instruments	9.26
Table 9.5	Fixed Instrumentation Summary	9.26
Table 9.6	Fixed Instrumentation Selection Matrix	9.28
Table 9.7	Estimated Cost Information for Fixed Instruments	9.29

(page intentionally left blank)

Bridge Scour and Stream Instability Countermeasures
Experience, Selection, and Design Guidance
Third Edition
Volume 2

DESIGN GUIDELINES

SECTION 1 - COUNTERMEASURES FOR STREAM INSTABILITY

Design Guideline 1 – Bendway Weirs/Stream Barbs.....	DG1.1
Design Guideline 2 – Spurs.....	DG2.1
Design Guideline 3 – Check Dams/Drop Structures.....	DG3.1

**SECTION 2 - COUNTERMEASURES FOR STREAMBANK AND ROADWAY
EMBANKMENT PROTECTION**

Design Guideline 4 – Riprap Revetment.....	DG4.1
Design Guideline 5 – Riprap Design for Embankment Overtopping	DG5.1
Design Guideline 6 – Wire Enclosed Riprap Mattress	DG6.1
Design Guideline 7 – Soil Cement.....	DG7.1
Design Guideline 8 – Articulating Concrete Block Systems	DG8.1
Design Guideline 9 – Grout-Filled Mattresses	DG9.1
Design Guideline 10 – Gabion Mattresses	DG10.1

SECTION 3 - COUNTERMEASURES FOR BRIDGE PIER PROTECTION

Design Guideline 8 – Articulating Concrete Block Systems at Bridge Piers.....	DG8.21
Design Guideline 9 – Grout-Filled Mattresses at Bridge Piers	DG9.14
Design Guideline 10 – Gabion Mattresses at Bridge Piers	DG10.13
Design Guideline 11 – Rock Riprap at Bridge Piers	DG11.1
Design Guideline 12 – Partially Grouted Riprap at Bridge Piers	DG12.1

SECTION 4 - COUNTERMEASURES FOR ABUTMENT PROTECTION

Design Guideline 13 – Grout/Cement Filled Bags	DG13.1
Design Guideline 14 – Rock Riprap at Bridge Abutments	DG14.1
Design Guideline 15 – Guide Banks.....	DG15.1

SECTION 5 - FILTER DESIGN

Design Guideline 16 – Filter Design	DG16.1
---	--------

SECTION 6 – SPECIAL APPLICATIONS

Design Guideline 17 – Riprap Design for Wave Attack	DG17.1
Design Guideline 18 – Riprap Protection for Bottomless Culverts	DG18.1
Design Guideline 19 – Concrete Armor Units.....	DG19.1

(page intentionally left blank)

ACKNOWLEDGMENTS

This manual is a major revision of the second edition of HEC-23 which was published in 2001. The writers wish to acknowledge the contributions made by Morgan S. Byars (formerly Ayres Associates) as a co-author of the first edition (1997). Technical assistance for the second edition was provided by J. Sterling Jones (FHWA) and A. Firenzi, J.L. Morris, E.V. Richardson, W.J. Spitz, and A. Waddoups (Ayres Associates).

DISCLAIMER

Mention of a manufacturer, registered or trade name does not constitute a guarantee or warranty of the product by the U.S. Department of Transportation or the Federal Highway Administration and does not imply their approval and/or endorsement to the exclusion of other products and/or manufacturers that may also be suitable.

(page intentionally left blank)

GLOSSARY

abrasion:	Removal of streambank material due to entrained sediment, ice, or debris rubbing against the bank.
aggradation:	General and progressive buildup of the longitudinal profile of a channel bed due to sediment deposition.
alluvial channel:	Channel wholly in alluvium; no bedrock is exposed in channel at low flow or likely to be exposed by erosion.
alluvial fan:	Fan-shaped deposit of material at the place where a stream issues from a narrow valley of high slope onto a plain or broad valley of low slope. An alluvial cone is made up of the finer materials suspended in flow while a debris cone is a mixture of all sizes and kinds of materials.
alluvial stream:	Stream which has formed its channel in cohesive or noncohesive materials that have been and can be transported by the stream.
alluvium:	Unconsolidated material deposited by a stream in a channel, floodplain, alluvial fan, or delta.
alternating bars:	Elongated deposits found alternately near the right and left banks of a channel.
ambient bed elevation:	Initial (unscoured) bed elevation.
anabranch:	Individual channel of an anabranching stream.
anabranching stream:	Stream whose flow is divided at normal and lower stages by large islands or, more rarely, by large bars; individual islands or bars are wider than about three times water width; channels are more widely and distinctly separated than in a braided stream.
anastomosing stream:	An anabranching stream.
angle of repose:	Maximum angle (as measured from the horizontal) at which gravel or sand particles can stand.
annual flood:	Maximum flow in 1 year (may be daily or instantaneous).
apron:	Protective material placed on a streambed to resist scour.
apron, launching:	Apron designed to settle and protect the side slopes of a scour hole after settlement.
armor (armoring):	Surfacing of channel bed, banks, or embankment slope to resist erosion and scour. (A) Natural process whereby an erosion-resistant layer of relatively large particles is formed on a streambed due to the removal of finer particles by streamflow; (B) placement of a covering to resist erosion.

articulated concrete mattress:	Rigid concrete slabs which can move without separating as scour occurs; usually hinged together with corrosion-resistant cable fasteners; primarily placed for lower bank protection.
average velocity:	Velocity at a given cross section determined by dividing discharge by cross sectional area.
avulsion:	Sudden change in the channel course that usually occurs when a stream breaks through its banks; usually associated with a flood or a catastrophic event.
backfill:	Material used to refill a ditch or other excavation, or the process of doing so.
backwater:	Increase in water surface elevation relative to elevation occurring under natural channel and floodplain conditions. It is induced by a bridge or other structure that obstructs or constricts the free flow of water in a channel.
backwater area:	Low-lying lands adjacent to a stream that may become flooded due to backwater.
bank:	Sides of a channel between which the flow is normally confined.
bank, left (right):	Sides of a channel as viewed in a downstream direction.
bankfull discharge:	Discharge that, on average, fills a channel to the point of overflowing.
bank protection:	Engineering works for the purpose of protecting streambanks from erosion.
bank revetment:	Erosion-resistant materials placed directly on a streambank to protect the bank from erosion.
bar:	Elongated deposit of alluvium within a channel, not permanently vegetated.
base floodplain:	Floodplain associated with the flood with a 100-year recurrence interval.
bed:	Bottom of a channel bounded by banks.
bed form:	Recognizable relief feature on the bed of a channel, such as a ripple, dune, plane bed, antidune, or bar. Bed forms are a consequence of the interaction between hydraulic forces (boundary shear stress) and the bed sediment.
bed layer:	Flow layer, several grain diameters thick (usually two) immediately above the bed.

bed load:	Sediment that is transported in a stream by rolling, sliding, or skipping along the bed or very close to it; considered to be within the bed layer (contact load).
bed load discharge (or bed load):	Quantity of bed load passing a cross section of a stream in a unit of time.
bed material:	Material found in and on the bed of a stream (May be transported as bed load or in suspension).
bedrock:	Solid rock exposed at the surface of the earth or overlain by soils and unconsolidated material.
bed sediment discharge:	Part of the total sediment discharge that is composed of grain sizes found in the bed and is equal to the transport capability of the flow.
bed shear stationary (tractive force):	Force per unit area exerted by a fluid flowing past a boundary.
bed slope:	Inclination of the channel bottom.
biotechnical engineering:	Countermeasure techniques that combine the use of vegetation with structural (hard) elements.
blanket:	Material covering all or a portion of a streambank to prevent erosion.
boulder:	Rock fragment whose diameter is greater than 250 mm.
braid:	Subordinate channel of a braided stream.
braided stream:	Stream whose flow is divided at normal stage by small mid-channel bars or small islands; the individual width of bars and islands is less than about three times water width; a braided stream has the aspect of a single large channel within which are subordinate channels.
bridge opening:	Cross-sectional area beneath a bridge that is available for conveyance of water.
bridge owner:	Any Federal, State, Local agency, or other entity responsible for a structure defined as a highway bridge by the National Bridge Inspection Standards (NBIS).
bridge waterway:	Area of a bridge opening available for flow, as measured below a specified stage and normal to the principal direction of flow.
bulk density:	Density of the water sediment mixture (mass per unit volume), including both water and sediment.

bulkhead:	Vertical, or near vertical, wall that supports a bank or an embankment; also may serve to protect against erosion.
bulking:	Increasing the water discharge to account for high concentrations of sediment in the flow.
catchment:	See drainage basin.
causeway:	Rock or earth embankment carrying a roadway across water.
caving:	Collapse of a bank caused by undermining due to the action of flowing water.
cellular-block mattress:	Interconnected concrete blocks with regular cavities placed directly on a streambank or filter to resist erosion. The cavities can permit bank drainage and the growth of vegetation where synthetic filter fabric is not used between the bank and mattress.
channel:	Bed and banks that confine surface flow of a stream.
channelization:	Straightening or deepening of a natural channel by artificial cutoffs, grading, flow-control measures, or diversion of flow into an engineered channel.
channel diversion:	Removal of flows by natural or artificial means from a natural length of channel.
channel pattern:	Aspect of a stream channel in plan view, with particular reference to the degree of sinuosity, braiding, and anabranching.
channel process:	Behavior of a channel with respect to shifting, erosion and sedimentation.
check dam:	Low dam or weir across a channel used to control stage or degradation.
choking (of flow):	Excessive constriction of flow which may cause severe backwater effect.
clay (mineral):	Particle whose diameter is in the range of 0.00024 to 0.004 mm.
clay plug:	Cutoff meander bend filled with fine grained cohesive sediments.
clear-water scour:	Scour at a pier or abutment (or contraction scour) when there is no movement of the bed material upstream of the bridge crossing at the flow causing bridge scour.
cobble:	Fragment of rock whose diameter is in the range of 64 to 250 mm.

concrete revetment:	Unreinforced or reinforced concrete slabs placed on the channel bed or banks to protect it from erosion.
confluence:	Junction of two or more streams.
constriction:	Natural or artificial control section, such as a bridge crossing, channel reach or dam, with limited flow capacity in which the upstream water surface elevation is related to discharge.
contact load:	Sediment particles that roll or slide along in almost continuous contact with the streambed (bed load).
contraction:	Effect of channel or bridge constriction on flow streamlines.
contraction scour:	Contraction scour, in a natural channel or at a bridge crossing, involves the removal of material from the bed and banks across all or most of the channel width. This component of scour results from a contraction of the flow area at the bridge which causes an increase in velocity and shear stress on the bed at the bridge. The contraction can be caused by the bridge or from a natural narrowing of the stream channel.
Coriolis force:	Inertial force caused by the Earth's rotation that deflects a moving body to the right in the Northern Hemisphere.
countermeasure:	Measure intended to prevent, delay or reduce the severity of hydraulic problems.
crib:	Frame structure filled with earth or stone ballast, designed to reduce energy and to deflect streamflow away from a bank or embankment.
critical shear stress:	Minimum amount of shear stress required to initiate soil particle motion.
crossing:	Relatively short and shallow reach of a stream between bends; also crossover or riffle.
cross section:	Section normal to the trend of a channel or flow.
current:	Water flowing through a channel.
current meter:	Instrument used to measure flow velocity.
cut bank:	Concave wall of a meandering stream.
cutoff:	(A) Direct channel, either natural or artificial, connecting two points on a stream, thereby shortening the original length of the channel and increasing its slope; (B) natural or artificial channel which develops across the neck of a meander loop (neck cutoff) or across a point bar (chute cutoff).

cutoff wall:	Wall, usually of sheet piling or concrete, that extends down to scour-resistant material or below the expected scour depth.
daily discharge:	Discharge averaged over 1 day (24 hours).
debris:	Floating or submerged material, such as logs, vegetation, or trash, transported by a stream.
degradation (bed):	General and progressive (long-term) lowering of the channel bed due to erosion, over a relatively long channel length.
depth of scour:	Vertical distance a streambed is lowered by scour below a reference elevation.
design flow (design flood):	Discharge that is selected as the basis for the design or evaluation of a hydraulic structure.
dike:	An impermeable linear structure for the control or containment of overbank flow. A dike-trending parallel with a streambank differs from a levee in that it extends for a much shorter distance along the bank, and it may be surrounded by water during floods.
dike (groin, spur, jetty):	Structure extending from a bank into a channel that is designed to: (A) reduce the stream velocity as the current passes through the dike, thus encouraging sediment deposition along the bank (permeable dike); or (B) deflect erosive current away from the streambank (impermeable dike).
discharge:	Volume of water passing through a channel during a given time.
dominant discharge:	(A) Discharge of water which is of sufficient magnitude and frequency to have a dominating effect in determining the characteristics and size of the stream course, channel, and bed; (B) discharge which determines the principal dimensions and characteristics of a natural channel. Dominant formative discharge depends on the maximum and mean discharge, duration of flow, and flood frequency. For hydraulic geometry relationships, it is taken to be the bankfull discharge which has a return period of approximately 1.5 years in many natural channels.
drainage basin:	Area confined by drainage divides, often having only one outlet for discharge (catchment, watershed).
drift:	Alternate term for vegetative "debris."
eddy current:	Vortex-type motion of a fluid flowing contrary to the main current, such as the circular water movement that occurs when the main flow becomes separated from the bank.
entrenched stream:	Stream cut into bedrock or consolidated deposits.

ephemeral stream:	Stream or reach of stream that does not flow for parts of the year. As used here, the term includes intermittent streams with flow less than perennial.
equilibrium scour:	Scour depth in sand-bed stream with dune bed about which live bed pier scour level fluctuates due to variability in bed material transport in the approach flow.
erosion:	Displacement of soil particles due to water or wind action.
erosion control matting:	Fibrous matting (e.g., jute, paper, etc.) placed or sprayed on a streambank for the purpose of resisting erosion or providing temporary stabilization until vegetation is established.
fabric mattress:	Grout-filled mattress used for streambank protection.
fall velocity:	Velocity at which a sediment particle falls through a column of still water.
fascine:	Matrix of willow or other natural material woven in bundles and used as a filter. Also, a streambank protection technique consisting of wire mesh or timber attached to a series of posts, sometimes in double rows; the space between the rows may be filled with rock, brush, or other materials.
fetch:	Area in which waves are generated by wind having a rather constant direction and speed; sometimes used synonymously with fetch length.
fetch length:	Horizontal distance (in the direction of the wind) over which wind generates waves and wind setup.
fill slope:	Side or end slope of an earth-fill embankment. Where a fill-slope forms the streamward face of a spill-through abutment, it is regarded as part of the abutment.
filter:	Layer of fabric (geotextile) or granular material (sand, gravel, or graded rock) placed between bank revetment (or bed protection) and soil for the following purposes: (1) to prevent the soil from moving through the revetment by piping, extrusion, or erosion; (2) to prevent the revetment from sinking into the soil; and (3) to permit natural seepage from the streambank, thus preventing the buildup of excessive hydrostatic pressure.
filter blanket:	Layer of graded sand and gravel laid between fine-grained material and riprap to serve as a filter.
filter fabric (cloth):	Geosynthetic fabric that serves the same purpose as a granular filter blanket.

fine sediment load:	That part of the total sediment load that is composed of particle sizes finer than those represented in the bed (wash load). Normally, the fine-sediment load is finer than 0.062 mm for sand-bed channels. Silts, clays and sand could be considered wash load in coarse gravel and cobble-bed channels.
flanking:	Erosion around the landward end of a stream stabilization countermeasure.
flashy stream:	Stream characterized by rapidly rising and falling stages, as indicated by a sharply peaked hydrograph. Typically associated with mountain streams or highly disturbed urbanized catchments. Most flashy streams are ephemeral, but some are perennial.
flood-frequency curve:	Graph indicating the probability that the annual flood discharge will exceed a given magnitude, or the recurrence interval corresponding to a given magnitude.
floodplain:	Nearly flat, alluvial lowland bordering a stream, that is subject to frequent inundation by floods.
flow-control structure:	Structure either within or outside a channel that acts as a countermeasure by controlling the direction, depth, or velocity of flowing water.
flow hazard:	Flow characteristics (discharge, stage, velocity, or duration) that are associated with a hydraulic problem or that can reasonably be considered of sufficient magnitude to cause a hydraulic problem or to test the effectiveness of a countermeasure.
flow slide:	Saturated soil materials which behave more like a liquid than a solid. A flow slide on a channel bank can result in a bank failure.
fluvial geomorphology:	Science dealing with morphology (form) and dynamics of streams and rivers.
fluvial system:	Natural river system consisting of (1) the drainage basin, watershed, or sediment source area, (2) tributary and mainstem river channels or sediment transfer zone, and (3) alluvial fans, valley fills and deltas, or the sediment deposition zone.
freeboard:	Vertical distance above a design stage that is allowed for waves, surges, drift, and other contingencies.
Froude Number:	Dimensionless number that represents the ratio of inertial to gravitational forces in open channel flow.
gabion:	Basket or compartmented rectangular container made of wire mesh. When filled with cobbles or other rock of suitable size, the gabion becomes a flexible and permeable unit with which flow- and erosion-control structures can be built.

general scour:	General scour is a lowering of the streambed across the stream or waterway at the bridge. This lowering may be uniform across the bed or non-uniform. That is, the depth of scour may be deeper in some parts of the cross section. General scour may result from contraction of the flow or other general scour conditions such as flow around a bend.
geomorphology/ morphology:	That science that deals with the form of the Earth, the general configuration of its surface, and the changes that take place due to erosion and deposition.
grade-control structure (sill, check dam):	Structure placed bank to bank across a stream channel (usually with its central axis perpendicular to flow) for the purpose of controlling bed slope and preventing scour or headcutting.
graded stream:	Geomorphic term used for streams that have apparently achieved a state of equilibrium between the rate of sediment transport and the rate of sediment supply throughout long reaches.
gravel:	Rock fragment whose diameter ranges from 2 to 64 mm.
groin:	Structure built from the bank of a stream in a direction transverse to the current to redirect the flow or reduce flow velocity. Many names are given to this structure, the most common being "spur," "spur dike," "transverse dike," "jetty," etc. Groins may be permeable, semi-permeable, or impermeable.
grout:	Fluid mixture of cement and water or of cement, sand, and water used to fill joints and voids.
guide bank:	Dike extending upstream from the approach embankment at either or both sides of the bridge opening to direct the flow through the opening. Some guide banks extend downstream from the bridge (also spur dike).
hardpoint:	Streambank protection structure whereby "soft" or erodible materials are removed from a bank and replaced by stone or compacted clay. Some hard points protrude a short distance into the channel to direct erosive currents away from the bank. Hard points also occur naturally along streambanks as passing currents remove erodible materials leaving nonerodible materials exposed.
headcutting:	Channel degradation associated with abrupt changes in the bed elevation (headcut) that generally migrates in an upstream direction.
helical flow:	Three-dimensional movement of water particles along a spiral path in the general direction of flow. These secondary-type currents are of most significance as flow passes through a bend; their net effect is to remove soil particles from the cut bank and deposit this material on a point bar.

hydraulics:	Applied science concerned with behavior and flow of liquids, especially in pipes, channels, structures, and the ground.
hydraulic model:	Small-scale physical or mathematical representation of a flow situation.
hydraulic problem:	An effect of streamflow, tidal flow, or wave action such that the integrity of the highway facility is destroyed, damaged, or endangered.
hydraulic radius:	Cross-sectional area of a stream divided by its wetted perimeter.
hydraulic structures:	Facilities used to impound, accommodate, convey or control the flow of water, such as dams, weirs, intakes, culverts, channels, and bridges.
hydrograph:	The graph of stage or discharge against time.
hydrology:	Science concerned with the occurrence, distribution, and circulation of water on the earth.
imbricated:	Reference to stream bed sediment particles, having an overlapping or shingled pattern.
icing:	Masses or sheets of ice formed on the frozen surface of a river or floodplain. When shoals in the river are frozen to the bottom or otherwise dammed, water under hydrostatic pressure is forced to the surface where it freezes.
incised reach:	A stretch of stream with an incised channel that only rarely overflows its banks.
incised stream:	Stream which has deepened its channel through the bed of the valley floor, so that the floodplain is a terrace.
invert:	Lowest point in the channel cross section or at flow control devices such as weirs, culverts, or dams.
island:	A permanently vegetated area, emergent at normal stage, that divides the flow of a stream. Islands originate by establishment of vegetation on a bar, by channel avulsion, or at the junction of minor tributary with a larger stream.
jack:	Device for flow control and protection of banks against lateral erosion consisting of three mutually perpendicular arms rigidly fixed at the center. Kellner jacks are made of steel struts strung with wire, and concrete jacks are made of reinforced concrete beams.

jack field:	Rows of jacks tied together with cables, some rows generally parallel with the banks and some perpendicular thereto or at an angle. Jack fields may be placed outside or within a channel.
jetty:	(A) Obstruction built of piles, rock, or other material extending from a bank into a stream, so placed as to induce bank building, or to protect against erosion; (B) similar obstruction to influence stream, lake, or tidal currents, or to protect a harbor (also spur).
lateral erosion:	Erosion in which the removal of material is extended horizontally as contrasted with degradation and scour in a vertical direction.
launching:	Release of undercut material (stone riprap, rubble, slag, etc.) downslope or into a scoured area.
levee:	Embankment, generally landward of top bank, that confines flow during high-water periods, thus preventing overflow into lowlands.
live-bed scour:	Scour at a pier or abutment (or contraction scour) when the bed material in the channel upstream of the bridge is moving at the flow causing bridge scour.
load (or sediment load):	Amount of sediment being moved by a stream.
local scour:	Removal of material from around piers, abutments, spurs, and embankments caused by an acceleration of flow and resulting vortices induced by obstructions to the flow.
longitudinal profile:	Profile of a stream or channel drawn along the length of its centerline. In drawing the profile, elevations of the water surface or the thalweg are plotted against distance as measured from the mouth or from an arbitrary initial point.
lower bank:	That portion of a streambank having an elevation less than the mean water level of the stream.
mathematical model:	Numerical representation of a flow situation using mathematical equations (also computer model).
mattress:	Blanket or revetment of materials interwoven or otherwise lashed together and placed to cover an area subject to scour.
meander or full meander:	Meander in a river consists of two consecutive loops, one flowing clockwise and the other counter-clockwise.
meander amplitude:	Distance between points of maximum curvature of successive meanders of opposite phase in a direction normal to the general course of the meander belt, measured between center lines of channels.

meander belt:	Distance between lines drawn tangent to the extreme limits of successive fully developed meanders.
meander length:	Distance along a stream between corresponding points of successive meanders.
meander loop:	Individual loop of a meandering or sinuous stream lying between inflection points with adjoining loops.
meander ratio:	Ratio of meander width to meander length.
meander radius of curvature:	Radius of a circle inscribed on the centerline of a meander loop.
meander scrolls:	Low, concentric ridges and swales on a floodplain, marking the successive positions of former meander loops.
meander width:	Amplitude of a fully developed meander measured from midstream to midstream.
meandering stream:	Stream having a sinuosity greater than some arbitrary value. The term also implies a moderate degree of pattern symmetry, imparted by regularity of size and repetition of meander loops. The channel generally exhibits a characteristic process of bank erosion and point bar deposition associated with systematically shifting meanders.
median diameter:	Particle diameter of the 50th percentile point on a size distribution curve such that half of the particles (by weight, number, or volume) are larger and half are smaller (D_{50}).
mid-channel bar:	Bar lacking permanent vegetal cover that divides the flow in a channel at normal stage.
middle bank:	Portion of a streambank having an elevation approximately the same as that of the mean water level of the stream.
migration:	Change in position of a channel by lateral erosion of one bank and simultaneous accretion of the opposite bank.
mud:	A soft, saturated mixture mainly of silt and clay.
natural levee:	Low ridge that slopes gently away from the channel banks that is formed along streambanks during floods by deposition.
nominal diameter:	Equivalent spherical diameter of a hypothetical sphere of the same volume as a given sediment particle.
nonalluvial channel:	Channel whose boundary is in bedrock or non-erodible material.

normal stage:	Water stage prevailing during the greater part of the year.
overbank flow:	Water movement that overtops the bank either due to stream stage or to overland surface water runoff.
oxbow:	Abandoned former meander loop that remains after a stream cuts a new, shorter channel across the narrow neck of a meander. Often bow-shaped or horseshoe-shaped.
pavement:	Streambank surface covering, usually impermeable, designed to serve as protection against erosion. Common pavements used on streambanks are concrete, compacted asphalt, and soil-cement.
paving:	Covering of stones on a channel bed or bank (used with reference to natural covering).
peaked stone dike:	Riprap placed parallel to the toe of a streambank (at the natural angle of repose of the stone) to prevent erosion of the toe and induce sediment deposition behind the dike.
perennial stream:	Stream or reach of a stream that flows continuously for all or most of the year.
phreatic line:	Upper boundary of the seepage water surface landward of a streambank.
pile:	Elongated member, usually made of timber, concrete, or steel, that serves as a structural component of a river-training structure.
pile dike:	Type of permeable structure for the protection of banks against caving; consists of a cluster of piles driven into the stream, braced and lashed together.
piping:	Removal of soil material through subsurface flow of seepage water that develops channels or "pipes" within the soil bank.
point bar:	Alluvial deposit of sand or gravel lacking permanent vegetal cover occurring in a channel at the inside of a meander loop, usually somewhat downstream from the apex of the loop.
poised stream:	Stream which, as a whole, maintains its slope, depths, and channel dimensions without any noticeable raising or lowering of its bed (stable stream). Such condition may be temporary from a geological point of view, but for practical engineering purposes, the stream may be considered stable.
probable maximum flood:	Very rare flood discharge value computed by hydro-meteorological methods, usually in connection with major hydraulic structures.

quarry-run stone:	Stone as received from a quarry without regard to gradation requirements.
railbank protection:	Type of countermeasure composed of rock-filled wire fabric supported by steel rails or posts driven into streambed.
rapid drawdown:	Lowering the water against a bank more quickly than the bank can drain without becoming unstable.
reach:	Segment of stream length that is arbitrarily bounded for purposes of study.
recurrence interval:	Reciprocal of the annual probability of exceedance of a hydrologic event (also return period, exceedance interval).
regime:	Condition of a stream or its channel with regard to stability. A stream is in regime if its channel has reached an equilibrium form as a result of its flow characteristics. Also, the general pattern of variation around a mean condition, as in flow regime, tidal regime, channel regime, sediment regime, etc. (used also to mean a set of physical characteristics of a river).
regime change:	Change in channel characteristics resulting from such things as changes in imposed flows, sediment loads, or slope.
regime channel:	Alluvial channel that has attained, more or less, a state of equilibrium with respect to erosion and deposition.
regime formula:	Formula relating stable alluvial channel dimensions or slope to discharge and sediment characteristics.
reinforced-earth bulkhead:	Retaining structure consisting of vertical panels and attached to reinforcing elements embedded in compacted backfill for supporting a streambank.
reinforced revetment:	Streambank protection method consisting of a continuous stone toe-fill along the base of a bank slope with intermittent fillets of stone placed perpendicular to the toe and extending back into the natural bank.
relief bridge:	An opening in an embankment on a floodplain to permit passage of overbank flow.
retard (retarder structure):	Permeable or impermeable linear structure in a channel parallel with the bank and usually at the toe of the bank, intended to reduce flow velocity, induce deposition, or deflect flow from the bank.
revetment:	Rigid or flexible armor placed to inhibit scour and lateral erosion. (See bank revetment).

riffle:	Natural, shallow flow area extending across a streambed in which the surface of flowing water is broken by waves or ripples. Typically, riffles alternate with pools along the length of a stream channel.
riparian:	Pertaining to anything connected with or adjacent to the banks of a stream (corridor, vegetation, zone, etc.).
riprap:	Layer or facing of rock or broken concrete dumped or placed to protect a structure or embankment from erosion; also the rock or broken concrete suitable for such use. Riprap has also been applied to almost all kinds of armor, including wire-enclosed riprap, grouted riprap, partially grouted riprap, sacked concrete, and concrete slabs.
river training:	Engineering works with or without the construction of embankment, built along a stream or reach of stream to direct or to lead the flow into a prescribed channel. Also, any structure configuration constructed in a stream or placed on, adjacent to, or in the vicinity of a streambank that is intended to deflect currents, induce sediment deposition, induce scour, or in some other way alter the flow and sediment regimes of the stream.
rock-and-wire mattress:	Flat wire cage or basket filled with stone or other suitable material and placed as protection against erosion.
roughness coefficient:	Numerical measure of the frictional resistance to flow in a channel, as in the Manning's or Chezy's formulas.
rubble:	Rough, irregular fragments of materials of random size used to retard erosion. The fragments may consist of broken concrete slabs, masonry, or other suitable refuse.
runoff:	That part of precipitation which appears in surface streams of either perennial or intermittent form.
sack revetment:	Sacks (e.g., burlap, paper, or nylon) filled with mortar, concrete, sand, stone or other available material used as protection against erosion.
saltation load:	Sediment bounced along the streambed by energy and turbulence of flow, and by other moving particles.
sand:	Rock fragment whose diameter is in the range of 0.062 to 2.0 mm.
scour:	Erosion of streambed or bank material due to flowing water; often considered as being localized (see local scour, contraction scour, total scour).

sediment or fluvial sediment:	Fragmental material transported, suspended, or deposited by water.
sediment concentration:	Weight or volume of sediment relative to the quantity of transporting (or suspending) fluid.
sediment discharge:	Quantity of sediment that is carried past any cross section of a stream in a unit of time. Discharge may be limited to certain sizes of sediment or to a specific part of the cross section.
sediment load:	Amount of sediment being moved by a stream.
sediment yield:	Total sediment outflow from a watershed or a drainage area at a point of reference and in a specified time period. This outflow is equal to the sediment discharge from the drainage area.
seepage:	Slow movement of water through small cracks and pores of the bank material.
shear stress:	See unit shear force.
shoal:	A relatively shallow submerged bank or bar in a body of water.
sill:	(A) Structure built under water, across the deep pools of a stream with the aim of changing the depth of the stream; (B) low structure built across an effluent stream, diversion channel or outlet to reduce flow or prevent flow until the main stream stage reaches the crest of the structure.
silt:	Particle whose diameter is in the range of 0.004 to 0.062 mm.
sinuosity:	Ratio between the thalweg length and the valley length of a stream.
slope (of channel or stream):	Fall per unit length along the channel centerline or thalweg.
slope protection:	Any measure such as riprap, paving, vegetation, revetment, brush or other material intended to protect a slope from erosion, slipping or caving, or to withstand external hydraulic pressure.
sloughing:	Sliding or collapse of overlying material; same ultimate effect as caving, but usually occurs when a bank or an underlying stratum is saturated.
slope-area method:	Method of estimating unmeasured flood discharges in a uniform channel reach using observed high-water levels.
slump:	Sudden slip or collapse of a bank, generally in the vertical direction and confined to a short distance, probably due to the substratum being washed out or having become unable to bear the weight above it.

soil-cement:	A designed mixture of soil and Portland cement compacted at a proper water content to form a blanket or structure that can resist erosion.
sorting:	Progressive reduction of size (or weight) of particles of the sediment load carried down a stream.
spill-through abutment:	Bridge abutment having a fill slope on the streamward side. The term originally referred to the "spill-through" of fill at an open abutment but is now applied to any abutment having such a slope.
spread footing:	Pier or abutment footing that transfers load directly to the earth.
spur:	Permeable or impermeable linear structure that projects into a channel from the bank to alter flow direction, induce deposition, or reduce flow velocity along the bank.
spur dike:	See guide bank.
stability:	Condition of a channel when, though it may change slightly at different times of the year as the result of varying conditions of flow and sediment charge, there is no appreciable change from year to year; that is, accretion balances erosion over the years.
stable channel:	Condition that exists when a stream has a bed slope and cross section which allows its channel to transport the water and sediment delivered from the upstream watershed without aggradation, degradation, or bank erosion (a graded stream).
stage:	Water-surface elevation of a stream with respect to a reference elevation.
stone riprap:	Natural cobbles, boulders, or rock dumped or placed as protection against erosion.
stream:	Body of water that may range in size from a large river to a small rill flowing in a channel. By extension, the term is sometimes applied to a natural channel or drainage course formed by flowing water whether it is occupied by water or not.
streambank erosion:	Removal of soil particles or a mass of particles from a bank surface due primarily to water action. Other factors such as weathering, ice and debris abrasion, chemical reactions, and land use changes may also directly or indirectly lead to bank erosion.
streambank failure:	Sudden collapse of a bank due to an unstable condition such as removal of material at the toe of the bank by scour.
streambank protection:	Any technique used to prevent erosion or failure of a streambank.

suspended sediment discharge:	Quantity of sediment passing through a stream cross section above the bed layer in a unit of time suspended by the turbulence of flow (suspended load).
sub-bed material:	Material underlying that portion of the streambed which is subject to direct action of the flow. Also, substrate.
subcritical, supercritical flow:	Open channel flow conditions with Froude Number less than and greater than unity, respectively.
tetrahedron:	Component of river-training works made of six steel or concrete struts fabricated in the shape of a pyramid.
tetrapod:	Bank protection component of precast concrete consisting of four legs joined at a central joint, with each leg making an angle of 109.5° with the other three.
thalweg	Line extending down a channel that follows the lowest elevation of the bed.
tieback:	Structure placed between revetment and bank to prevent flanking.
timber or brush mattress:	Revetment made of brush, poles, logs, or lumber interwoven or otherwise lashed together. The completed mattress is then placed on the bank of a stream and weighted with ballast.
toe of bank:	That portion of a stream cross section where the lower bank terminates and the channel bottom or the opposite lower bank begins.
toe protection:	Loose stones laid or dumped at the toe of an embankment, groin, etc., or masonry or concrete wall built at the junction of the bank and the bed in channels or at extremities of hydraulic structures to counteract erosion.
total scour:	Sum of long-term degradation, general (contraction) scour, and local scour.
total sediment load:	Sum of suspended load and bed load or the sum of bed material load and wash load of a stream (total load).
tractive force:	Drag or shear on a streambed or bank caused by passing water which tends to move soil particles along with the streamflow.
trench-fill revetment:	Stone, concrete, or masonry material placed in a trench dug behind and parallel to an eroding streambank. When the erosive action of the stream reaches the trench, the material placed in the trench armors the bank and thus retards further erosion.

turbulence:	Motion of fluids in which local velocities and pressures fluctuate irregularly in a random manner as opposed to laminar flow where all particles of the fluid move in distinct and separate lines.
ultimate scour:	Maximum depth of scour attained for a given flow condition. May require multiple flow events and in cemented or cohesive soils may be achieved over a long time period.
uniform flow:	Flow of constant cross section and velocity through a reach of channel at a given time. Both the energy slope and the water slope are equal to the bed slope under conditions of uniform flow.
unit discharge:	Discharge per unit width (may be average over a cross section, or local at a point).
unit shear force (shear stress):	Force or drag developed at the channel bed by flowing water. For uniform flow, this force is equal to a component of the gravity force acting in a direction parallel to the channel bed on a unit wetted area. Usually in units of stress, Pa (N/m^2) or (lb/ft^2).
unsteady flow:	Flow of variable discharge and velocity through a cross section with respect to time.
upper bank:	Portion of a streambank having an elevation greater than the average water level of the stream.
velocity:	Time rate of flow usually expressed in m/s (ft/sec). Average velocity is the velocity at a given cross section determined by dividing discharge by cross-sectional area.
vertical abutment:	An abutment, usually with wingwalls, that has no fill slope on its streamward side.
vortex:	Turbulent eddy in the flow generally caused by an obstruction such as a bridge pier or abutment (e.g., horseshoe vortex).
wandering channel:	Channel exhibiting a more or less non-systematic process of channel shifting, erosion and deposition, with no definite meanders or braided pattern.
wandering thalweg:	Thalweg whose position in the channel shifts during floods and typically serves as an inset channel that conveys all or most of the stream flow at normal or lower stages.
wash load:	Suspended material of very small size (generally clays and colloids) originating primarily from erosion on the land slopes of the drainage area and present to a negligible degree in the bed itself.

watershed:	See drainage basin.
waterway opening width (area):	Width (area) of bridge opening at (below) a specified stage, measured normal to the principal direction of flow.
weephole:	A hole in an impermeable wall or revetment to relieve the neutral stress or pore pressure in the soil.
windrow revetment:	Row of stone placed landward of the top of an eroding streambank. As the windrow is undercut, the stone is launched downslope, thus armoring the bank.
wire mesh:	Wire woven to form a mesh; where used as an integral part of a countermeasure, openings are of suitable size and shape to enclose rock or broken concrete or to function on fence-like spurs and retards.

CHAPTER 1

INTRODUCTION

1.1 PURPOSE

The purpose of this document is to identify and provide design guidelines for bridge scour and stream instability countermeasures that have been implemented by various State departments of transportation (DOTs) in the United States. Countermeasure experience, selection, and design guidance are consolidated from other FHWA publications in this document to support a comprehensive analysis of scour and stream instability problems and provide a range of solutions to those problems. The results of recently completed National Cooperative Highway Research Program (NCHRP) projects are incorporated in the design guidance, including: countermeasures to protect bridge piers and abutments from scour; riprap design criteria, specifications, and quality control, and environmentally sensitive channel and bank protection measures. Selected innovative countermeasure concepts and guidance derived from practice outside the United States are introduced. In addition, guidance for the preparation of Plans of Action (POA) for scour critical bridges has been expanded to include a standard template for POA and instructions for its use.

1.2 BACKGROUND

Scour and stream instability problems have always threatened the safety of our nation's highway bridges. Countermeasures for these problems are defined as measures incorporated into a highway-stream crossing system to monitor, control, inhibit, change, delay, or minimize stream instability and bridge scour problems. A plan of action, which can include timely installation of stream instability and scour countermeasures, must be developed for each scour critical bridge. Monitoring structures during and/or after flood events as a part of a plan of action, can also be considered an appropriate countermeasure.

Numerous measures are available to counteract the actions of humans and nature which contribute to the instability of alluvial streams. These include measures installed in or near the stream to protect highways and bridges by stabilizing a local reach of the stream, and measures which can be incorporated into the highway design to ensure the structural integrity of the highway in an unstable stream environment. Countermeasures include river stabilizing works over a reach of the river up- and downstream of the crossing. Countermeasures may be installed at the time of highway construction or retrofitted to resolve scour and instability problems as they develop at existing crossings. The selection, location, and design of countermeasures are dependent on hydraulic and geomorphic factors that contribute to stream instability, as well as costs and construction and maintenance considerations.

While considerable research has been dedicated to design of countermeasures for scour and stream instability, many countermeasures have evolved through a trial and error process. In addition, some countermeasures have been applied successfully in one locale, state or region, but have failed when installations were attempted under different geomorphic or hydraulic conditions. In some cases, a countermeasure that has been used with success in one state or region is virtually unknown to highway design and maintenance personnel in another state or region. Thus, there is a significant need for information transfer regarding stream instability and bridge scour countermeasure design, installation, and maintenance.

1.3 MANUAL ORGANIZATION

This manual is presented in two volumes. Volume 1 is organized to:

- Provide strategies and general guidance for developing a Plan of Action for a scour critical bridge (Chapter 2)
- Highlight the various groups of countermeasures and identify their individual characteristics (Chapter 2)
- For a wide-range of countermeasures, list information on their functional applicability to a particular problem, their suitability to specific river environments, the general level of maintenance resources required, and which DOTs have experience with specific countermeasures (Chapter 2 and the Countermeasures Matrix).
- Provide general criteria for selection of countermeasures for bridge scour and stream instability problems (Chapter 3)
- Discuss countermeasure design concepts including design approach, hydraulic analysis, and environmental permitting (Chapter 4).
- Provide an overview of design considerations related to riprap: including filters; riprap specifications, testing and quality control; riprap failure modes, and inspection guidance (Chapter 5).
- Discuss biotechnical engineering approaches and provide conceptual guidelines (Chapter 6).
- Provide detailed design guidelines for specific bridge scour and stream instability countermeasures (Chapter 7 and Volume 2, Design Guidelines 1 through 19).
- Summarize general guidance for other countermeasures and case histories of countermeasure performance (Chapter 8).
- Provide criteria for selecting portable and fixed instrumentation for monitoring scour at bridges (Chapter 9).

Volume 2 presents detailed Design Guidelines for 16 stream instability and bridge scour countermeasures. Design Guidelines are presented for the following functional applications:

- Countermeasures for stream instability
- Countermeasures for streambank and roadway embankment protection
- Countermeasures for bridge pier protection
- Countermeasures for abutment protection
- Granular and geotextile filter requirements
- Special Applications

1.4 COMPREHENSIVE ANALYSIS

This manual is part of a set of Hydraulic Engineering Circulars (HEC) issued to provide guidance for bridge scour and stream stability analyses. The three manuals in this set are:

- HEC-18 Evaluating Scour at Bridges
- HEC-20 Stream Stability at Highway Structures
- HEC-23 Bridge Scour and Stream Instability Countermeasures

The Flow Chart shown in Figure 1.1 illustrates the interrelationship between these three documents and emphasizes that they should be used as a set. A comprehensive scour analysis or stability evaluation must be based on information presented in all three documents.

While the flow chart does not attempt to present every detail of a complete stream stability and scour evaluation, it has sufficient detail to show the major elements in a complete analysis, the logical flow of a typical analysis or evaluation, and the most common decision points and feedback loops. It clearly shows how the three documents tie together, and recognizes the differences between design of a new bridge and evaluation of an existing bridge.

The HEC-20 (Lagasse et al. 2001a) block of the flow chart outlines initial data collection and site reconnaissance activities leading to an understanding of the problem, evaluation of river system stability and potential future response. The HEC-20 procedures include both qualitative and quantitative geomorphic and engineering analysis techniques which help establish the level of analysis necessary to solve the stream instability and scour problem for design of a new bridge, or for the evaluation of an existing bridge that may require rehabilitation or countermeasures. The "Classify Stream," "Evaluate Stream Stability," and "Assess Stream Response" portions of the HEC-20 block are expanded in HEC-20 into a six-step Level 1 and an eight-step Level 2 analysis procedure. In some cases, the HEC-20 analysis may be sufficient to determine that stream instability and/or scour problems do not exist, i.e., the bridge has a "low risk of failure" regarding scour susceptibility.

In most cases, the analysis or evaluation will progress to the HEC-18 (Richardson and Davis 2001) block of the flow chart. Here more detailed hydrologic and hydraulic data are developed, with the specific approach determined by the level of complexity of the problem and waterway characteristics (e.g., tidal or riverine). The "Scour Analysis" portion of the HEC-18 block encompasses a seven-step specific design approach which includes evaluation of the components of total scour.

Since bridge scour evaluation requires multidisciplinary inputs, it is often advisable for the hydraulic engineer to involve structural and geotechnical engineers at this stage of the analysis. **Once the total scour prism is plotted, then all three disciplines must be involved in a determination of the structural stability of the bridge foundation.**

For a new bridge design, if the structure is stable the design process can proceed to consideration of environmental impacts, cost, constructability, and maintainability or if the bridge is unstable, revise the design and repeat the analysis. For an existing bridge, a finding of structural stability at this stage will result in a "low risk" evaluation, with no further action required. However, a Plan of Action must be developed for an unstable existing bridge (scour critical) to correct the problem as outlined in Sections 1.5 and 2.1.

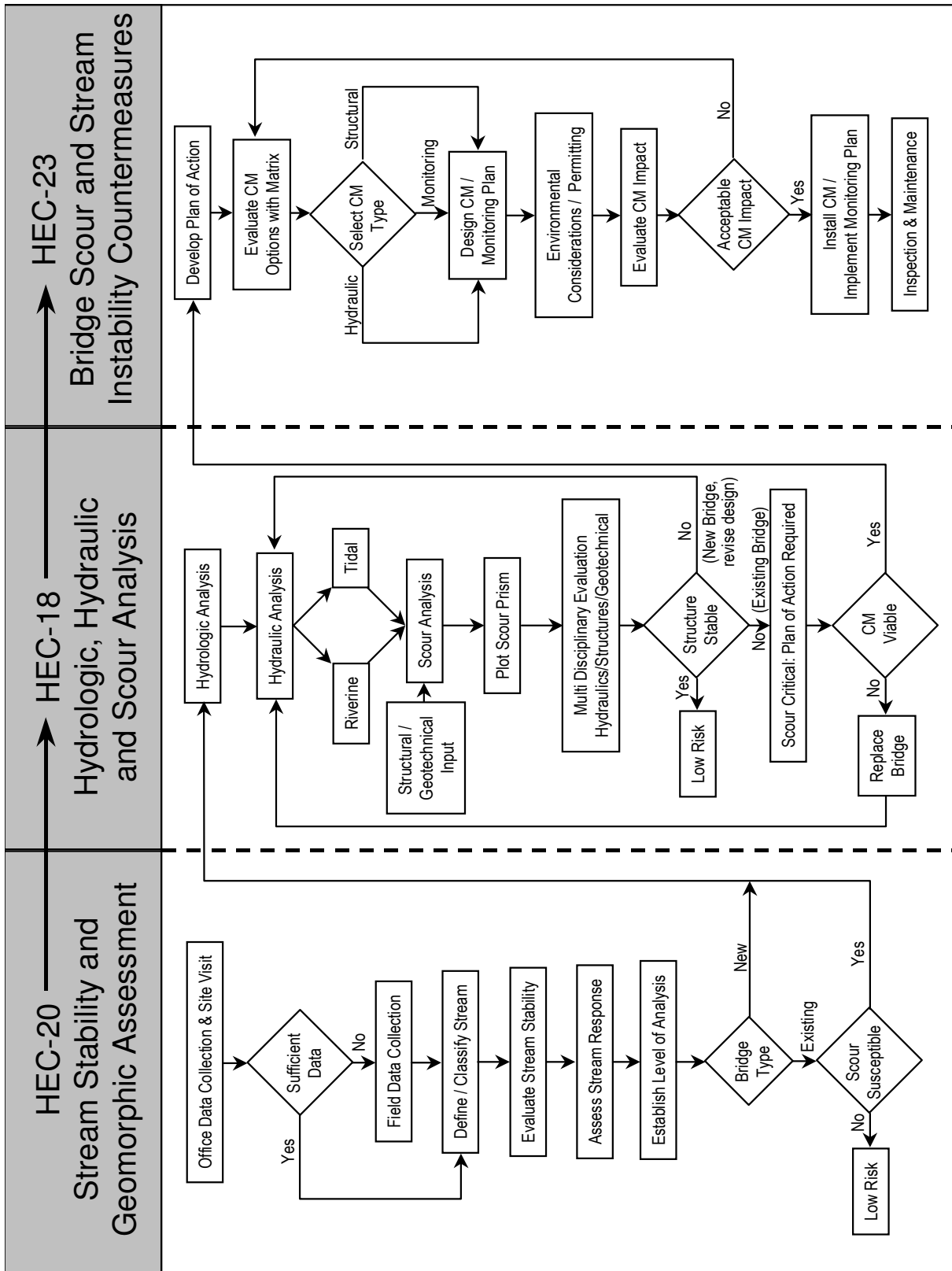

Figure 1.1. Flow chart for scour and stream stability analysis and evaluation.

The scour problem may be so serious that installing countermeasures would not provide a viable solution and a replacement or substantial bridge rehabilitation would be required. If countermeasures would correct the stream instability or scour problem at a reasonable cost and with acceptable environmental impacts, the analysis would progress to the HEC-23 block of the flow chart.

Hydraulic Engineering Circular 23 provides a range of resources to support bridge scour and stream instability countermeasure selection and design. A countermeasure matrix (Chapter 2) presents a variety of countermeasures that have been used to control scour and stream instability at bridges.

HEC-23 also includes specific Design Guidelines for the most common (and some uncommon) countermeasures used by DOTs, or references to sources of design guidance. Inherent in the design of any countermeasure are an evaluation of potential environmental impacts, permitting for countermeasure installation, and redesign, if necessary, to meet environmental requirements. As shown in the flow chart, to be effective most countermeasures will require a monitoring plan, inspection, and maintenance.

1.5 PLAN OF ACTION

Each bridge identified as scour critical in Item 113 of the National Bridge Inventory must have a plan of action as required by the National Bridge Inspection Standards (NBIS) regulation 23 CFR 650.313(e) describing what will be done to address the scour problem. The plan of action should include a monitoring program and a schedule for the timely design and construction of hydraulic or structural countermeasures, if any are warranted. The purpose of the plan of action is to provide for the safety of the traveling public, and to minimize the potential for bridge failure, by prescribing site-specific actions that will be taken at the bridge to correct the scour problem. The actions (or countermeasures) taken can be categorized as hydraulic countermeasures, structural countermeasures, biotechnical countermeasures, or a monitoring program (see Chapter 2).

Hydraulic countermeasures are primarily designed to modify the stream flow or resist erosive forces. Examples of hydraulic countermeasures include the installation of river training structures and the placement of riprap at piers or abutments. Structural countermeasures usually involve modification of the bridge substructure to increase bridge stability. Typical structural countermeasures are underpinning and pier modification.

A scour monitoring program as part of the plan of action includes two primary components:

1. The frequency and type of measurements to facilitate early identification of potential scour problems, and
2. Specific instructions describing precisely what must be done if a bridge is at risk due to scour.

Note that a monitoring program involves more than just instrumentation. It must describe specific actions to be taken once a scour problem has been identified. In some cases, a properly designed scour monitoring program can be an acceptable countermeasure by itself. However, monitoring does not fix the scour problem, and therefore, does not allow changing the Item 113 coding on a scour-critical bridge. In other cases, a monitoring program allows time to implement hydraulic or structural countermeasures. Information in Section 2.1 outlines how to develop a plan of action for a scour critical bridge, and provides specific strategies for deciding when and how to implement a monitoring program.

1.6 DUAL SYSTEM OF UNITS

This edition of HEC-23 uses dual units (English and SI metric). The "English" system of units as used throughout this manual refers to U.S. Customary units. **In Appendix A, the metric (SI) unit of measurement is explained. The conversion factors, physical properties of water in the SI and English systems of units, sediment particle size grade scale, and some common equivalent hydraulic units are also given.** This edition uses for the unit of length the meter (m) or foot (ft); of mass the kilogram (kg) or slug; of weight/force the newton (N) or pound (lb); of pressure the Pascal (Pa, N/m²) or (lb/ft²); and of temperature the degree Centigrade (°C) or Fahrenheit (°F). The unit of time is the same in SI as in English system (seconds, s). Sediment particle size is given in millimeters (mm), but in calculations the decimal equivalent of millimeters in meters is used (1 mm = 0.001 m) or for the English system feet (ft). The values of some hydraulic engineering terms used in the text in SI units and their equivalent English units are given in Table 1.1.

Table 1.1. Commonly Used Engineering Terms in SI and English Units.		
Term	English Units	SI Units
Length	3.28 ft	1 m
Volume	35.31 ft ³	1 m ³
Discharge	35.31 ft ³ /s	1 m ³ /s
Acceleration of Gravity	32.2 ft/s ²	9.81 m/s ²
Unit Weight of Water	62.4 lb/ft ³	9800 N/m ³
Density of Water	1.94 slugs/ft ³	1000 kg/m ³
Density of Quartz	5.14 slugs/ft ³	2647 kg/m ³
Specific Gravity of Quartz	2.65	2.65
Specific Gravity of Water	1	1
Temperature	°F	°C = 5/9 (°F - 32)

CHAPTER 2

PLAN OF ACTION AND THE COUNTERMEASURES MATRIX

2.1 STRATEGIES FOR PROTECTING SCOUR CRITICAL BRIDGES

2.1.1 Technical Advisories

The National Bridge Inspection Standards (23 CFR 650, Subpart C) requires bridge owners to maintain a bridge inspection program that includes procedures for underwater inspection. A national scour evaluation program as an integral part of the National Bridge Inspection standards was established in 1988 by Technical Advisory T5140.20 (USDOT 1988).

Technical Advisory T5140.20 was superseded in 1991 by Technical Advisory T5140.23, to provide more guidance on the development and implementation of procedures for evaluating bridge scour to meet the requirements of 23 CFR 650, Subpart C). Specifically, Technical Advisory T5140.23 provides guidance on:

1. Developing and implementing a scour evaluation for designing new bridges
2. Evaluating existing bridges for scour vulnerability
3. Using scour countermeasures
4. Improving the state-of-practice for estimating scour at bridges

The Technical Advisory suggests that scour evaluations of both new and existing bridges should be conducted by an interdisciplinary team comprised of hydraulic, geotechnical and structural engineers. The recommendation for new bridges is to design the bridge foundation for potential scour by assuming that all streambed material in the computed scour prism has been removed and is not available for bearing or lateral support. Bridge foundations should be designed to withstand scour during floods equal to or less than the 100-year flood, and should be checked to ensure they will not fail during a superflood (on the order of the 500-year event). The procedures for computing the scour prism, which represents calculated scour conditions, are detailed in HEC-18 (Richardson and Davis 2001).

The recommendation for existing bridges is to evaluate every bridge over a waterway for scour to determine if it is scour critical or low risk. For a scour critical bridge, prudent measures should be taken for its protection. A scour critical bridge is one with abutment or pier foundations that are coded as unstable due to (1) observed scour at the bridge site, or (2) scour potential as determined from a scour evaluation study. A bridge that is not scour critical was defined as low risk, generally considered to have little potential for scour or stream instability problems. Results of the scour evaluation study for existing bridges are coded in Item 113 of the 1995 Recording and Coding Guide for the Structure Inventory and Appraisal of the Nations Bridges - FHWA Report PD-96-001 (more commonly known as the Coding Guide) (FHWA 1995, 2001).

Technical Advisory T5140.23 specifies that a plan of action should be developed for each existing bridge found to be scour critical. **The two primary components of the plan of action are instructions regarding the type and frequency of inspections to be made at the bridge, and a schedule for the timely design and construction of scour countermeasures.** The Technical Advisory further recommends appropriate training and instruction for bridge inspectors in scour issues. These include issues such as collection

and comparison of cross section data, identification of conditions indicative of potential scour problems, and effective notification procedures when an actual or potential problem is identified at or in the vicinity of the bridge.

Information in this chapter provides direction for developing a plan of action. A "standard" template for preparing a plan of action is referenced and discussed. Issues related to the type and frequency of inspections are described, followed by the range of scour countermeasures available that could be incorporated in the plan of action. Finally, the countermeasures matrix is introduced, which provides a concise summary of the available countermeasures in categories classified as hydraulic, structural, biotechnical, and monitoring. The remainder of HEC-23 details the various scour countermeasures available in each category, which might be implemented through a plan of action.

2.1.2 Additional Guidance and Requirements

Revisions to the Coding Guide for Item 113 (FHWA 2001) provide new guidance for coding bridges for **observed** and **assessed** scour conditions. HEC-23 is referenced for guidance on countermeasures for the protection of bridge foundations. These revisions to Item 113 codes allow bridge owners to consider countermeasures when coding (or re-coding) a bridge as stable, low risk, or scour critical based on the results of a bridge inspection and/or a scour evaluation.

As noted, responsibility for the National Bridge Inspection Standards (NBIS) is established in the Code of Federal Regulations (23 CFR 650, Sub-part C). **Updates to 23 CFR 650, Sub-part C, underscore actions required for bridges that are determined to be scour critical.** These include preparation of a plan of action to monitor known and potential deficiencies and to address critical findings, and monitoring of bridges in accordance with the plan for bridges that are scour critical (USDOT 2004, effective January 2005).

Inspection procedures for bridge owners are delineated in the CFR (650.313). Regarding follow-up on critical findings, the regulation requires that: (1) a state- or federal agency-wide procedure be established to assure that critical findings are addressed in a timely manner, and (2) FHWA be notified periodically of the actions taken to resolve or monitor critical findings.

2.1.3 Management Strategies for a Plan of Action

As described above, when a bridge is found to be scour critical, either by inspection or by evaluation (i.e., assessed or calculated), a plan of action must be developed and implemented for that bridge. While many bridges may be found to be scour critical, the severity of the problem and the risk involved to the traveling public can vary dramatically. As a result, the management strategy for the plan of action, including factors such as the urgency of the response, the type and frequency of the inspection work, the redundancy in the plan, and amount of money and resources allocated to countermeasures (including monitoring), can vary from one scour critical bridge to the next.

For example, a bridge found to be scour critical by inspection, such as during an underwater inspection that finds a substantial scour hole undermining the foundation, would obviously be a greater concern than a bridge that is currently stable, but rated scour critical based on calculations of conditions that might develop during the 100-year flood. In the first case, the bridge has already experienced scour and is at risk of failure, whereas in the second case

the bridge is not presently at risk, but might develop a scour problem in the future when it is subjected to the 100-year flood. The resulting management strategy for developing and implementing the plan of action would be much more urgent in the first case.

The management strategy may also vary according to the importance of the roadway to the transportation network and may require a risk-based analysis. For example, a bridge with high average daily traffic (ADT), or one that provides the only access in and out of a given area would be a greater concern than a low ADT bridge, or one for which alternate routes or detours were available. Similarly, a bridge that provides access for a hospital or fire station would be very important and might justify more resources or concern in developing and implementing a plan of action. A bridge that is along an evacuation route or provides access to an airport might also require a different level of response in developing a plan of action.

The management strategy might vary as a result of other repair or replacement plans. For example, a bridge found to be scour critical but already programmed for replacement in the near future might be treated differently from another bridge that was newer, or not considered for replacement for many years. In the first case, the use of monitoring as a countermeasure until replacement can occur might be reasonable, whereas in the second case, a structural countermeasure, at substantially greater cost, would probably be necessary.

As noted in Section 2.1.2, updates to Item 113 codes allow bridge owners to consider countermeasures when coding a bridge as stable, low risk, or scour critical, based on the results of a bridge inspection and/or a scour evaluation. Hydraulic or structural countermeasures that have been selected and designed by the interdisciplinary team, and properly installed can change a scour critical coding under Item 113 to a low risk code. Also, the updates allow bridge owners to consider mitigation measures installed during and/or immediately after a flood event in determining the appropriate Item 113 code. For this case, a plan of action must include specific instructions for monitoring the countermeasures to reduce the risk to the public users from a bridge failure.

2.1.4 Inspection Strategies in a Plan of Action

The type and frequency of inspection work called for in the plan of action can also vary dramatically based on the management strategy. Bridges that are more important, or at higher risk, may justify more intense inspection efforts. Factors such as when to begin the inspection work, how often to visit the bridge during a flood, and when monitoring is no longer necessary must be addressed in the plan of action.

If a bridge foundation is determined to be unstable for the assessed or calculated stream stability or scour condition, and field inspection shows no evidence of a scour problem, the inspection requirements may not be any more than those required by the NBIS. For example, a bridge that is rated scour critical by calculations, but has a relatively deep piles in an erosion-resistant material and has been in place for many years with no sign of scour, might adequately be addressed through the regular inspection cycle and after major flood events.

If more frequent inspections are required, the plan of action should to describe when to begin monitoring efforts. Initiation of inspection work can be based on discharge or stage measurements. While discharge is used to define or analyze scour conditions (e.g. scour during the 100-year flood), it is typically not the best criteria for triggering flood monitoring and inspection work. The primary limitation of a discharge based criteria is that the inspector

often does not have a way of determining the discharge in the river, such as gaging station or flood forecasting results.

A more viable approach to define when to begin scour measurements has been to use the stage data corresponding to a critical discharge condition. However, even stage data must be specified in a manner that is easily understood and measurable by bridge inspection crews. For example, defining the initiation of scour measurements based on flood stage is only practical if stage information is readily available, and/or a gaging station is located at or near the bridge. Alternatively, if the critical water surface elevation is defined based on the distance from the guard rail or curb line of the bridge, the inspector could measure that distance and know when to begin data collection. An even more direct approach is to mark a line on a pier or abutment that defines when data collection or monitoring should be initiated.

On a basin wide basis, it may be possible to define flood watch requirements based on flood forecasting information. A simplistic approach is to implement monitoring after a given amount of rain has occurred. For example, the criteria might be to begin monitoring after a cumulative rainfall of 10 inches (25 cm) in 24 hours. A general criteria such as this might require the bridge inspection crews to immediately begin monitoring all scour critical bridges in that basin. Alternatively, in a more instrumented watershed with extensive flood warning systems, the use of GIS data and flood forecasting models could define in advance which bridges will need to be monitored at what times during the flood.

Once the flood inspection program is underway, the inspector needs to know exactly what constitutes a critical scour condition, and what to do when this condition has been detected. Specifically, a scour critical water surface elevation should be defined in the plan of action for each pier or abutment to be monitored. Information on who to call and what action to take once that elevation has been reached should also be detailed in the plan of action. This could extend as far as discussion of emergency repair measures and/or bridge closure instructions.

2.1.5 Closure Instructions

Closure instructions can range from load restrictions, lane closures or complete bridge closure, again depending on the severity of the problem and the risk involved. The method of closure should also be described. In some cases barricades may be adequate, while in other cases it may require, or justify based on the risk involved, the posting of a law enforcement officer at the bridge to insure that no one attempts to cross the structure. The availability and description of detour routes should be included in the plan of action, so when a bridge is closed an alternative route has already been defined to minimize traffic disruption. The scour vulnerability of bridges along the detour route should be known and evaluated when developing detour alternatives.

Instructions on the criteria for re-opening the bridge or traffic lane, or removing the load restriction, should also be provided. In many cases, the act of closing is easier than re-opening. Virtually anyone who detects a problem, such as an inspector, law enforcement officer, or bridge owner could make the decision to close a bridge, but the decision about when it is safe to re-open may require more information and engineering analysis by the interdisciplinary team. The person authorized to make the decision to re-open should be identified in the plan of action.

2.1.6 Countermeasure Alternatives and Schedule

The two primary components of the plan of action are instructions regarding the type and frequency of inspections to be made at the bridge, and a schedule for the timely design and construction of scour countermeasures. Developing a schedule for the timely construction of countermeasures first requires defining the preferred countermeasure alternative. It is typical that several different alternatives might be appropriate countermeasures for a given scour or stream stability problem at a bridge. A comprehensive plan of action should provide enough information that an independent reviewer could arrive at the same conclusion regarding the preferred alternative.

In order to evaluate alternatives a conceptual design should be developed for various alternatives. This facilitates evaluation of the engineering feasibility of the alternative, and allows developing preliminary cost estimates. The various alternatives developed should be presented in the plan of action, and a narrative provided describing why the preferred alternative was chosen.

Once the preferred alternative is selected, a schedule should be developed for the timely design and construction of the preferred alternative. It may be that a more intense monitoring alternative is recommended as a measure to reduce the risk from scour, prior to design and construction of countermeasures to make the bridge safe from scour.

2.1.7 Other Information Necessary in a Plan of Action

The plan of action can include other information to the inspector, including special conditions to watch for such as debris build-up and associated problems. It might include instructions on communications with the media, such as who is authorized to make statements and what information should be provided. Actions such as bridge closures and/or bridge failures generate a lot of interest and concern from both the media and the public. Developing a communications plan ahead of time can minimize confusion and mis-communication. The plan of action might also describe emergency action countermeasures, such as what type of riprap is adequate, local sources, and installation methods during a flood situation.

2.1.8 Development and Implementation of a POA

The development of a POA means that bridge owners have held meetings involving the appropriate personnel from internal units within their corresponding agency (design, construction, inspection and maintenance, districts, and others as applicable) and with external entities (local authorities such as a commissioner, police department, fire department, and others as needed) to identify and document:

- General information about the bridge responsibility for POA
- Scour vulnerability
- Recommended countermeasure(s) or alternatives
- NBI coding information
- Countermeasure selection(s) including priority ranking and cost
- Bridge closure plan
- Detour route
- Any other supportive information

Additional guidance on developing a POA is presented in Section 2.2 and **Appendix B**.

The implementation of a POA means that bridge owners have completed disseminating POAs to the appropriate personnel within their internal offices/units and external entities and have met with these offices/units and with external entities to communicate:

- General information and instructions contained in each POA
- Individuals responsible for the POA implementation
- Detour routes
- When to close/open a bridge
- Countermeasure selection
- Design and installation schedules

Bridge owners should make sure that responsible parties identified in the POA understand their roles and responsibilities that they are provided with periodic training on the implementation of selected components of a POA such as bridge closure/opening procedures. Implementation also includes establishing the frequency to conduct periodic reviews and updates of the information presented in a POA.

2.2 STANDARD TEMPLATE FOR A PLAN OF ACTION

2.2.1 Overview

In order to facilitate the development of a POA, the FHWA has created a "standard" template for bridges that are scour critical. The standard template and instructions for completing a POA are provided in Appendix B. This template includes the minimum information recommended by FHWA for a POA.

The template is intended to be a guide and tool for bridge owners to use in developing their POAs. The template provides the program manager with a summary of the type of information that should be part of a plan of action for a bridge identified as scour critical. Bridge owners may also want to consider using the POA standard template for bridges which have unknown foundations (i.e., foundation characteristics such as width, depth, and length may be unknown).

All the fields in the template may be modified so that local terminology is employed, unique information may be added regarding local and site-specific scour and stream stability concerns, and local sources of information may be included. The electronic Microsoft Word document template can be downloaded from the FHWA website:

<http://www.fhwa.dot.gov/engineering/hydraulics/bridgehyd/poa.cfm>

All blocks in this template will expand automatically to allow additional space. Where check boxes are provided, they can be checked by double-clicking on the box and selecting the "checked" option.

To provide guidance and training on preparation of POA for scour critical bridges, the FHWA developed an on-line module which includes the POA standard template and illustrates its application to field case studies. This training module which is referenced as NHI Course No. 135085 is offered by NHI and can be accessed at:

http://fhwa.acrobat.com/n135085_seminar

A state's Bridge Management System is a useful source of data for developing a POA. Many DOT's are now using information technology (IT) systems that provide immediate access via the bridge engineer's desktop computer to an integrated system of bridge management information and data bases. Much of the information outlined in the template may be obtained from these systems.

2.2.2 Executive Summary

The standard template contains ten sections. Sections 1 through 4 are intended as an executive summary for the busy reviewer/manager who may not need the details of Sections 5 through 10, and show:

- Section 1: General information
- Section 2: Who prepared the POA
- Section 3: The source of the problem
- Section 4: What actions are recommended and their status

To assist in completing a POA using the template, Appendix B contains general guidance for each section of the template. An abbreviated set of instructions is also appended to the template.

2.3 THE COUNTERMEASURE MATRIX

Selecting the countermeasures to be included in the plan of action requires evaluating a number of alternatives. These alternatives could include hydraulic countermeasures, structural countermeasures or monitoring, either individually or in some combination. **To facilitate selection of alternatives to be considered in the plan of action, a matrix describing the various countermeasures and their attributes has been developed. This countermeasure matrix is introduced and described in this section.**

A wide variety of countermeasures have been used to control channel instability and scour at bridge foundations. The countermeasure matrix, presented in Table 2.1, is organized to highlight the various groups of countermeasures and to identify their individual characteristics. The left column of the matrix lists types of countermeasures in groups. In each row of the matrix, distinctive characteristics of a particular countermeasure are identified. The matrix identifies most countermeasures used by DOTs and lists information on their functional applicability to a particular problem, their suitability to specific river environments, the general level of maintenance resources required, and which states have experience with specific countermeasures. Finally, a reference source for design guidelines is noted, where available.

Countermeasures have been organized into groups based on their functionality with respect to scour and stream instability. The four main groups of countermeasures are: **hydraulic countermeasures, structural countermeasures, biotechnical countermeasures, and monitoring.** The following outline identifies the countermeasure groups in the matrix:

Group 1. Hydraulic Countermeasures

- Group 1.A: River training structures
 - Transverse structures
 - Longitudinal structures
 - Areal structures
- Group 1.B: Armoring countermeasures
 - Revetments and bed armor
 - Rigid
 - Flexible/articulating
 - Local scour armoring

Group 2. Structural Countermeasures

- Foundation strengthening
- Pier geometry modification

Group 3. Biotechnical Countermeasures

Group 4. Monitoring

- Fixed instrumentation
- Portable instrumentation
- Visual monitoring

2.4 COUNTERMEASURE GROUPS

2.4.1 Group 1. Hydraulic Countermeasures

Hydraulic countermeasures are those which are primarily designed either to modify the flow or resist erosive forces caused by the flow. Hydraulic countermeasures are organized into two groups: **river training structures and armoring countermeasures**. The performance of hydraulic countermeasures is dependent on design considerations such as edge treatment and filter requirements, which are discussed in Sections 5.2 and 5.4, respectively.

Group 1.A River Training Structures. River training structures are those which modify the flow. River training structures are distinctive in that they alter hydraulics to mitigate undesirable erosional and/or depositional conditions at a particular location or in a river reach. River training structures can be constructed of various material types and are not distinguished by their construction material, but rather, by their orientation to flow. River training structures are described as **transverse, longitudinal** or **areal** depending on their orientation to the stream flow.

- **Transverse river training structures** are countermeasures which project into the flow field at an angle or perpendicular to the direction of flow.
- **Longitudinal river training structures** are countermeasures which are oriented parallel to the flow field or along a bankline.
- **Areal river training structures** are countermeasures which cannot be described as transverse or longitudinal when acting as a system. This group also includes countermeasure "treatments" which have areal characteristics such as channelization, flow relief, and sediment detention.

Table 2.1 STREAM INSTABILITY AND BRIDGE SCOUR COUNTERMEASURES MATRIX

Countermeasure Group	Countermeasure Characteristics																INSTALLATION EXPERIENCE BY STATE	DESIGN GUIDELINE REFERENCE*
	FUNCTIONAL APPLICATIONS						SUITABLE RIVER ENVIRONMENT							MAINTENANCE				
	Local Scour		Contraction Scour	Stream Instability		Overtopping Flow	River Type	Stream Size	Bend Radius	Velocity	Bed Material	Ice/Debris Load	Bank Slope	Floodplain	Estimated Allocation of Resources			
	Abutments	Piers ⁴	Floodplain and Channel	Vertical	Lateral	Approach Embankments	B = braided M = meandering S = straight	W = wide M = moderate S = small	L = long M = moderate S = short	F = fast M = moderate S = slow	C = coarse bed S = sand bed F = fine bed	H = high M = moderate L = low	V = very steep S = steep M = mild	W = wide M = moderate N = narrow/none	H = high M = moderate L = low			
GROUP 1. HYDRAULIC COUNTERMEASURES																		
GROUP 1.A. RIVER TRAINING STRUCTURES																		
TRANSVERSE STRUCTURES																		
Impermeable spurs (jetties, groins, wing dams)	▶	▶	○	○	●	○	B, M	W, M	L, M	✓	✓	✓	✓	✓	M - L	Widely Used	DG 2	
Permeable spurs (fences, netting)	▶	○	○	○	●	○	B, M	W, M	L, M	M, S	S, F	L	✓	✓	H - M	Widely Used	DG 2	
Transverse dikes	○	○	○	○	●	○	B, M	W, M	✓	✓	✓	✓	✓	✓	M - L	NE		
Bendway weirs/Stream barbs ¹	▶	▶	○	○	●	○	M	✓	M, S	✓	✓	✓	✓	✓	L	CO, ID, IL, MO, MT, OR, WA	DG 1	
Hardpoints	○	○	○	○	●	○	✓	✓	✓	✓	✓	✓	✓	✓	L	CA, ND, NE, SD	CH 8	
Drop structures (check dams, grade control)	▶	▶	▶	●	○	○	✓	✓	✓	✓	✓	✓	✓	✓	M	Widely Used	DG 3	
Embankment Spurs	▶	○	▶	○	○	○	✓	✓	✓	✓	✓	✓	✓	W	L	AK, OK		
LONGITUDINAL STRUCTURES																		
Longitudinal dikes (crib/rock toe/embankments)	▶	○	○	○	●	▶	✓	✓	L, M	✓	✓	M, L	✓	✓	M - L	AK, AZ, CA, OK, OR, MS	CH 8	
Retards	▶	○	○	○	●	○	✓	✓	L, M	✓	S, F	L	✓	✓	H - M	Widely Used	CH 8	
Bulkheads	●	○	○	○	●	○	✓	✓	✓	✓	✓	✓	V, S	✓	M	Widely Used	CH 8	
Guide banks	●	▶	▶	○	▶	▶	✓	W, M	✓	✓	✓	✓	✓	W, M	M - L	Widely Used	DG 15	
AREAL STRUCTURES/TREATMENTS																		
Jacks/tetrahedron jetty fields	○	○	○	○	●	○	B, M	W, M	L	M, S	S, F	M, L	✓	W, M	M	Widely Used	CH 8	
Vanes	○	▶	○	○	●	○	B, M	W, M	L, M	M, S	S, F	L	✓	✓	H - M	IA		
Channelization	▶	▶	○	○	●	○	B, M	✓	✓	✓	✓	✓	✓	✓	M	MS, MO, MT, TX	CH 8	
Flow relief (overflow, relief bridge)	▶	▶	●	○	○	●	✓	✓	✓	✓	✓	✓	✓	W	M	Widely Used		
Sediment detention basin	○	○	○	●	○	○	✓	✓	✓	✓	C, S	✓	✓	✓	H - M	Widely Used		
GROUP 1.B. ARMORING COUNTERMEASURES																		
REVTMENTS AND BED ARMOR																		
Rigid																		
Soil cement	●	●	▶	▶	●	●	✓	✓	✓	✓	S, F	✓	✓	✓	L	AZ, CO, NM	DG 7	
Roller compacted concrete	●	▶	●	●	●	●	✓	✓	✓	✓	S, F	✓	✓	✓	L	Widely Used		
Concrete pavement	▶	○	●	▶	●	▶	✓	✓	✓	✓	✓	✓	S, M	✓	M	Widely Used		
Rigid grout filled mattress/concrete fabric mat	▶	○	▶	▶	●	▶	✓	✓	✓	✓	✓	✓	S, M	✓	M	GA, MA, MD, ME, SD, WA		
Fully grouted riprap	○	○	○	○	▶	○	✓	✓	✓	✓	✓	✓	S, M	✓	M	AZ, CA, CT, ME, MI, TN	CH 5	
Flexible/articulating																		
Riprap	●	●	▶	▶	●	▶	✓	✓	✓	✓	✓	✓	S, M	✓	M	Widely Used	DG 4	
Self launching riprap (windrow)	○	○	○	○	▶	○	✓	✓	✓	✓	C, S	✓	V, S	✓	H - M	GA, CA, IL, PA	DG 4	
Riprap fill-trench	▶	○	○	○	●	○	✓	✓	✓	✓	✓	✓	✓	✓	M	Widely Used	DG 4	
Gabions/gabion mattress ²	●	●	▶	▶	●	▶	✓	✓	✓	✓	S, F	M, L	✓	✓	M	Widely Used	DG 11	
Wire enclosed riprap mattress (rail bank/sausage)	●	○	○	○	●	○	✓	✓	✓	M, S	S, F	M, L	S, M	✓	M	AZ, CO, NM	DG 6	
Articulated blocks (interlocking and/or cable tied)	●	●	●	▶	●	●	✓	✓	✓	✓	✓	✓	S, M	✓	M - L	Widely Used	DG 9	
Concrete/grout mattress (fabric-formed)	●	▶	●	▶	●	▶	✓	✓	✓	M, S	✓	✓	S, M	✓	M - L	OR, CA, IA, IL, AZ	DG 10	
Partially grouted riprap	●	●	▶	▶	●	○	✓	✓	✓	✓	✓	✓	S, M	✓	L	European practice	DG 12	
LOCAL SCOUR ARMORING																		
Riprap (fill/apron)	●	●	N/A	N/A	N/A	N/A	✓	✓	✓	✓	✓	✓	S, M	✓	H - M	Widely Used	DG 8, DG 14	
Fully grouted riprap	▶	○	N/A	N/A	N/A	N/A	✓	✓	✓	✓	✓	✓	S, M	✓	H - M	Widely Used	CH 5	
Concrete armor units (Toskanes, tetrapods, etc.) ³	▶	▶	N/A	N/A	N/A	N/A	✓	✓	✓	✓	✓	✓	M	✓	M - L	AZ, PA, NY, VA	CH 5	
Grout filled bags/sand cement bags	●	▶	N/A	N/A	N/A	N/A	✓	✓	✓	✓	✓	✓	M, L	M	H - M	Widely Used	DG 13	
Gabions/gabion mattress ²	●	●	N/A	N/A	N/A	N/A	✓	✓	✓	✓	S, F	M, L	S, M	✓	M	FL, WA, TN, OR	DG 11	
Articulated blocks (interlocking and/or cable tied)	●	●	N/A	N/A	N/A	N/A	✓	✓	✓	✓	✓	✓	S, M	✓	M - L	Widely Used	DG 9	
Sheet pile/cofferdam	▶	▶	N/A	N/A	N/A	N/A	✓	✓	✓	✓	✓	✓	✓	✓	M - L	CA, CT, FL, NH, WA		
Partially grouted riprap	●	●	N/A	N/A	N/A	N/A	✓	✓	✓	✓	✓	✓	S, M	✓	L	European practice	DG 12	

- well suited/primary use
- ▶ possible application/secondary use
- unsuitable/rarely used
- N/A not applicable

✓ suitable for the full range of the characteristic

DG# HEC-23 Design Guideline
CH# HEC-23 Chapter

Table 2.1 STREAM INSTABILITY AND BRIDGE SCOUR COUNTERMEASURES MATRIX (continued).

Countermeasure Group	Countermeasure Characteristics																
	FUNCTIONAL APPLICATIONS						SUITABLE RIVER ENVIRONMENT							MAINTENANCE	INSTALLATION EXPERIENCE BY STATE	DESIGN GUIDELINE REFERENCE*	
	Local Scour		Contraction Scour	Stream Instability		Overtopping Flow	River Type	Stream Size	Bend Radius	Velocity	Bed Material ⁵	Ice/Debris Load	Bank Slope	Floodplain			Estimated Allocation of Resources
	Abutments	Piers ⁴	Floodplain and Channel	Vertical	Lateral	Approach Embankments	B = braided M = meandering S = straight	W = wide M = moderate S = small	L = long M = moderate S = short	F = fast M = moderate S = slow	C = coarse bed S = sand bed F = fine bed	H = high M = moderate L = low	V = very steep S = steep M = mild	W = wide M = moderate N = narrow/none			H = high M = moderate L = low
GROUP 2. STRUCTURAL COUNTERMEASURES																	
FOUNDATION STRENGTHENING																	
Crutch bents/Underpinning	○	●	●	●	◐	N/A	✓	✓	✓	✓	✓	✓	✓	✓	L	FL, NC, OR, TX	
Cross bracing	○	●	●	●	○	N/A	✓	✓	✓	✓	✓	✓	✓	✓	L	NC, FL, LA	
Continuous spans	○	●	●	●	○	N/A	✓	✓	✓	✓	✓	✓	✓	✓	L	NC	
Pumped concrete/grout under footing	●	●	◐	◐	◐	N/A	✓	✓	✓	✓	✓	✓	✓	✓	M	Widely Used	DG 13
Lower foundation	●	●	●	●	●	N/A	✓	✓	✓	✓	✓	✓	✓	✓	L	CA, OR, TX	
PIER GEOMETRY MODIFICATION																	
Extended footings	N/A	●	N/A	N/A	N/A	N/A	✓	✓	✓	✓	✓	✓	✓	✓	L	Widely Used	
Pier shape modifications	N/A	●	N/A	N/A	N/A	N/A	✓	✓	✓	✓	✓	✓	✓	✓	M	FL	
Debris deflectors	N/A	●	N/A	N/A	N/A	N/A	✓	✓	✓	✓	✓	✓	✓	✓	H - M	CA, FL, NM, OR	
Sacrificial piles/dolphins	N/A	●	N/A	N/A	N/A	N/A	✓	✓	✓	✓	✓	✓	✓	✓	H - M		
GROUP 3. BIOTECHNICAL COUNTERMEASURES⁵																	
Vegetated geosynthetic products	○	○	○	○	●	◐	M, S	M, S	✓	M, S	✓	M, L	M, S	✓	H - M	Widely Used	CH 6
Fascines/woody mats	○	○	○	○	●	○	✓	M, S	✓	M, S	✓	L	M, S	✓	H - M	Widely Used	CH 6
Vegetated riprap	○	○	○	○	●	◐	✓	✓	✓	✓	✓	✓	M, S	✓	M - L	Widely Used	CH 6
Root wads	○	○	○	○	●	○	✓	M, S	✓	M, S	✓	L	M	✓	H - M	Widely Used	CH 6
Live staking	○	○	○	○	●	○	✓	M, S	✓	M, S	✓	M, L	M, S	✓	H - M	Widely Used	CH 6
GROUP 4. MONITORING																	
FIXED INSTRUMENTATION																	
Sonar scour monitor	◐	●	●	●	◐	○	✓	✓	✓	✓	✓	L	✓	✓	M	CO, FL, IN, NY, VA, TX	CH 9
Magnetic sliding collar	●	●	●	●	◐	○	✓	✓	✓	✓	S, F	✓	✓	✓	M	Widely Used	CH 9
Float out device	●	●	●	●	●	●	✓	✓	✓	✓	S, F	✓	✓	✓	L	AZ, CA, NV	CH 9
Sounding rods	◐	●	●	●	◐	○	✓	✓	✓	M, S	C	M, L	✓	✓	H	AR, IA, NY	CH 9
PORTABLE INSTRUMENTATION																	
Physical probes	●	●	●	●	●	○	✓	✓	✓	M, S	✓	M, L	✓	✓	L	Widely Used	CH 9
Sonar probes	●	●	●	●	●	○	✓	✓	✓	M, S	✓	L	✓	✓	L	Widely Used	CH 9
VISUAL MONITORING																	
Periodic Inspection	●	●	●	●	●	●	✓	✓	✓	✓	✓	M, L	✓	✓	H	Widely Used	CH 2
Flood watch	●	●	●	●	●	●	✓	✓	✓	✓	✓	M, L	✓	✓	H	Widely Used	CH 2

- well suited/primary use
- ◐ possible application/secondary use
- unsuitable/rarely used
- N/A not applicable

✓ suitable for the full range of the characteristic

DG# HEC-23 Design Guideline
CH# HEC-23 Chapter

NOTES:

1. There is limited but successful field experience using bendway weirs/stream bars as stream instability countermeasures.
2. Performance of welded vs. twisted wire, and PVC coated vs. uncoated wire gabions is not distinguished in the matrix.
3. There is limited but successful field experience using concrete armor units for scour protection at bridge piers.
4. Piers at new bridges cannot rely on countermeasures to reduce the design depths of foundation elements (Federal guidance).
5. Biotechnical countermeasures are only intended for stream banks, not stream beds. This matrix assumes that any biotechnical treatments are fully grown, with well-established root systems. The toe of any streambank treatment should be reinforced with rock riprap or other armor material, as discussed in Chapter 6 of this document.
6. See Chapter 3 for discussion of selection criteria for countermeasures.
7. See Chapter 6 for discussion of biotechnical engineering countermeasures.
8. See Chapter 8 for discussion of other countermeasures and case histories of performance.

Group 1.B Armoring Countermeasures. Armoring countermeasures are distinctive because they resist the erosive forces caused by a hydraulic condition. Armoring countermeasures do not necessarily alter the hydraulics of a reach, but act as a resistant layer to hydraulic shear stresses providing protection to the more erodible materials underneath. Armoring countermeasures generally do not vary by function, but vary more in material type. Armoring countermeasures are classified by two functional groups: **revetments and bed armoring** or **local scour armoring**.

- **Revetments and bed armoring** are used to protect the channel bank and/or bed from erosive/hydraulic forces. They are usually applied in a blanket type fashion for areal coverage. Revetments and bed armoring can be classified as either **rigid** or **flexible/articulating**. **Rigid** revetments and bed armoring are typically impermeable and do not have the ability to conform to changes in the supporting surface. These are subject to failure due to undermining. **Flexible/ articulating** revetments and bed armoring can conform to changes in the supporting surface and adjust to settlement; however, these countermeasures can fail by removal and displacement of the armor material.
- **Local scour armoring** is used specifically to protect individual substructure elements of a bridge from local scour. Generally, the same material used for revetments and bed armoring is used for local scour armoring, but these countermeasures are designed and placed to resist local vortices created by obstructions to the flow.

2.4.2 Group 2. Structural Countermeasures

Structural countermeasures involve modification of the bridge structure (foundation) to prevent failure from scour. Typically, the substructure is modified to increase bridge stability after scour has occurred or when a bridge is assessed as scour critical. These modifications are classified as either **foundation strengthening** or **pier geometry modifications**.

- **Foundation strengthening** includes additions to the original structure which will reinforce and/or extend the foundations of the bridge. These countermeasures are designed to prevent failure when the channel bed is lowered to an expected scour elevation, or to restore structural integrity after scour has occurred. Design and construction of bridges with continuous spans provide redundancy against catastrophic failure due to substructure displacement as a result of scour. Retrofitting a simple span bridge with continuous spans could also serve as a countermeasure after scour has occurred or when a bridge is assessed as scour critical.
- **Pier geometry modifications** are used to either reduce local scour at bridge piers or to transfer scour to another location. These modifications are used primarily to minimize local scour.

2.4.3 Group 3. Biotechnical Countermeasures

Vegetation has been used increasingly over the past few decades to control streambank erosion or as a bank stabilizer. It has been used primarily in stream restoration and rehabilitation projects and can be applied independently or in combination with structural countermeasures. There are several terms that describe vegetative streambank stabilization and countermeasures. The use of 'soft' revetments (consisting solely of living plant materials or plant products) is often referred to as bioengineering. The techniques that combine the use of vegetation with structural (hard) elements include biotechnical engineering and biotechnical slope protection. Where riprap constitutes the "hard" component of biotechnical slope protection, the term vegetated riprap is also used (see Chapter 6).

The matrix considers representative categories for biotechnically engineered countermeasures (which incorporate rock) including:

- **Vegetated geosynthetic products**
- **Facines/woody mats**
- **Vegetated riprap**
- **Root wads**
- **Live staking**

Biotechnical engineering can be a useful and cost-effective tool in controlling bank or channel erosion, while increasing the aesthetics and habitat diversity of the site. However, where failure of the countermeasure could lead to failure of a bridge or highway structure, the only acceptable solution in the immediate vicinity of a structure is a traditional, "hard" engineering approach.

2.4.4 Group 4. Monitoring

Monitoring describes activities used to facilitate early identification of potential scour problems. Monitoring could also serve as a continuous survey of the scour progress around the bridge foundations. While monitoring does not fix the scour problem at a scour critical bridge, it allows for action to be taken before the safety of the public is threatened by the potential failure of the bridge. Monitoring can be accomplished with instrumentation or visual inspection. A well designed monitoring program can be a very cost-effective countermeasure. Two types of instrumentation are used to monitor bridge scour: **fixed instruments** and **portable instruments** (see Chapter 9).

- **Fixed instrumentation** describes monitoring devices which are attached to the bridge structure to detect scour at a particular location. Typically, fixed monitors are located at piers and abutments. The number and location of piers to be instrumented should be defined, as it may be impractical to place a fixed instrument at every pier and abutment on a bridge. Instruments such as sonar monitors can be used to provide a timeline of scour, whereas instruments such as magnetic sliding collars can only be used to monitor the maximum scour depth. Data from fixed instruments can be downloaded manually at the site or it can be telemetered to another location.
- **Portable instrumentation** describes monitoring devices that can be manually carried and used along a bridge and transported from one bridge to another. Portable instruments are more cost effective in monitoring an entire bridge than fixed instruments; however, they do not offer a continuous watch over the structure. The allowable level of risk will affect the frequency of data collection using portable instruments.
- **Visual inspection** describes standard monitoring practices of inspecting the bridge on a regular interval and increasing monitoring efforts during high flow events (flood watch). Typically, bridges are inspected on a biennial schedule where channel bed elevations at each pier location are taken. The channel bed elevations should be compared with historical cross sections to identify changes due to scour. Channel elevations should also be taken during and after high flow events. If measurements cannot be safely collected during a high flow event, the bridge owner should determine if the bridge is at risk and if closure is necessary. Underwater inspections of the foundations could be used as part of the visual inspection after a flood.

2.5 COUNTERMEASURE CHARACTERISTICS

The countermeasure matrix (Table 2.1) was developed to identify distinctive characteristics for each type of countermeasure. Five categories of countermeasure characteristics were defined to aid in the selection and implementation of countermeasures:

- Functional Applications
- Suitable River Environment
- Maintenance
- Installation/Experience by State
- Design Guidelines Reference

These categories were used to answer the following questions:

- For what type of problem is the countermeasure applicable?
- In what type of river environment is the countermeasure best suited or, are there river environments where the countermeasure will not perform well?
- What level of resources will need to be allocated for maintenance of the countermeasure?
- What states or regions in the U.S. have experience with this countermeasure?
- Where do I obtain design guidance reference material?

2.5.1 Functional Applications

The functional applications category describes the type of scour or stream instability problem for which the countermeasure is prescribed. The six main categories of functional applications are local scour at abutments and piers, contraction scour, vertical and lateral instability, and overtopping flow on approach embankments. Vertical instability implies the long-term processes of aggradation or degradation over relatively long river reaches, and lateral instability involves a long-term process of channel migration and bankline erosion problems. While overtopping flow considers, primarily, roadway approach embankments, the functional application could also include overtopping of countermeasures such as spurs or guide banks. To associate the appropriate countermeasure type with a particular problem, filled circles, half circles and open circle are used in the matrix as described below:

- **well suited/primary use** - the countermeasure is well suited for the application; the countermeasure has a good record of success for the application; the countermeasure was implemented primarily for this application.
- ◐ **possible application/secondary use** - the countermeasure can be used for the application; the countermeasure has been used with limited success for the application; the countermeasure was implemented primarily for another application but also can be designed to function for this application.
In addition, this symbol can identify an application for which the countermeasure has performed successfully and was implemented primarily for that application, but there is only a limited amount of data on its performance and therefore the application cannot be rated as well suited.
- **unsuitable/rarely used** - the countermeasure is not well suited for the application; the countermeasure has a poor record of success for the application; the countermeasure was not intended for this application.
- N/A not applicable** - the countermeasure is not applicable to this functional application.

2.5.2 Suitable River Environment

This category describes the characteristics of the river environment for which a given countermeasure is best suited or under which there would be a reasonable expectation of success. Conversely, this category could indicate conditions under which experience has shown a countermeasure may not perform well. The river environment characteristics that can have a significant effect on countermeasure selection or performance are:

- River type
- Stream size (width)
- Bend radius
- Flow velocity
- Bed material
- Ice/debris load
- Bank condition
- Floodplain (width)

For each environmental characteristic, a qualitative range is established (e.g., stream size: **Wide**, **Moderate**, or **Small**) to serve as a suitability discriminator. While most characteristics are self explanatory, both HEC-20 ("Stream Stability at Highway Structures") and HDS 6 ("River Engineering for Highway Encroachments") provide guidance on the range and definitions of these characteristics of the river environment (Lagasse et al. 2001a; Richardson et al. 2001). In the context of this matrix, the bank condition (slope) characteristic (**Very Steep**, **Steep** or **Mild**) considers the effectiveness of a given countermeasure to **protect** a bank with that configuration, **or** in some cases, the suitability for the countermeasure to **armor** a bank with that configuration.

- ✓ Where a block is **checked** for a given countermeasure under an environmental characteristic, the countermeasure is considered suitable or has been applied successfully for the full range of that environmental characteristic.

The checked block means that the characteristic **does not influence** the selection of the countermeasure, i.e., the countermeasure is suitable for the full range of that characteristic. For example, **guide banks** have been applied successfully in braided, meandering, and straight streams; however, **bendway weirs/stream barbs** are most suitable for installation on meandering streams.

For further discussion of these and other river environment characteristics, see Chapter 3.

2.5.3 Maintenance

The maintenance category identifies the estimated level of maintenance that may need to be allocated to service the countermeasure. The ratings in this category range from "**Low**" to "**High**" and are subjective. The ratings represent the relative amount of resources required for maintenance with respect to other countermeasures within the matrix shown in Table 2.1. A low rating indicates that the countermeasure is relatively maintenance free, a moderate rating indicates that some maintenance is required, and a high rating indicates that the countermeasure requires more maintenance than most of the countermeasures in the matrix.

2.5.4 Installation/Experience by State Departments of Transportation

This category identifies DOTs for which information on the use of a particular countermeasure was available. These listings may not include all of the states which have used a particular countermeasure. Information on state use was obtained from three sources: a National Cooperative Highway Program questionnaire (University of Minnesota survey for NCHRP Project 24-07(1); Brice and Blodgett, "Countermeasures for Hydraulic Problems at Bridges, Volumes 1 and 2," (1978); and correspondence with DOT staff. Certain countermeasures are used by many states. These countermeasures have a listing of "Widely Used" in this category. Both successful, and unsuccessful experiences are reflected by the listing.

2.5.5 Design Guideline Reference

Reference manuals which provide guidance in countermeasure design have been developed by government agencies through research programs. The FHWA has produced a wealth of information through the federally coordinated program of highway research and development (see Chapter 10, References). In addition, each Design Guideline in Volume 2 identifies reference manuals where additional guidance on design can be obtained. Countermeasures for which design guidelines are provided within this document are referenced using **DG#**, where # represents the number assigned to the design guideline (see Chapter 7, Countermeasure Design Guidelines and Volume 2). Where additional design guidance can be found in Volume 1, the appropriate Chapter (CH) is referenced in the matrix.

2.5.6 Summary

The countermeasures matrix is a convenient reference guide on a wide range of countermeasures applicable to scour and stream stability problems. A comprehensive plan of action should provide conceptual design and cost information on several alternative countermeasures, with a recommended alternative based on a variety of engineering, environmental and cost factors. The countermeasures matrix is a good way to begin identifying and prioritizing possible alternatives. The information provided in the matrix related to functional applications, suitable river environment, and maintenance issues should facilitate preliminary selection of feasible alternatives prior to more detailed investigation.

(page intentionally left blank)

CHAPTER 3

CONSIDERATIONS FOR SELECTING COUNTERMEASURES

3.1 INTRODUCTION

As previously noted, a countermeasure is defined as a measure incorporated into a highway-stream crossing system to monitor, control, inhibit, change, delay, or minimize stream and bridge stability problems. A monitoring program at structures during and/or after flood events and river stabilizing works over a reach of the river up and downstream of the crossing can also be considered countermeasures.

Countermeasures may be installed at the time of highway construction or retrofitted to resolve stability problems at existing crossings. Retrofitting is good economics and good engineering practice in many locations because the magnitude, location, and nature of potential stability problems are not always discernible at the design stage, and indeed, may take a period of several years to develop.

A countermeasure does not need to be a separate structure, but may be an integral part of the highway. For example, relief bridges on floodplains are countermeasures which alleviate scour from flow contraction at the bridge over the main stream channel. Some features that are integral to the highway design serve as countermeasures to minimize stream stability problems. Abutments and piers properly aligned with the flow reduce local scour and contraction scour. Also, reducing the number of piers and/or setting back the abutments reduces contraction scour.

Countermeasures which are not integral to the highway may serve one function at one location and a different function at another. For example, bank revetment may be installed to control bank erosion from meander migration, or it may be used to stabilize streambanks in the contracted area at a bridge. Other countermeasures are useful for one function only. This category of countermeasures includes spurs constructed in the stream channel to control meander migration.

In selecting a countermeasure it is necessary to evaluate how the stream might respond to the countermeasure, and also how the stream may respond as the result of other activities upstream and downstream.

A countermeasure for scour critical bridges and unknown foundations could also be monitoring a bridge during and/or after a flood event. If monitoring is selected and if the risk of scour failure is high, protection to reduce the risk such as riprap or instrumentation should be provided. Even if riprap is placed around piers or abutments, the high risk bridge should be monitored during and inspected after floods. If monitoring is selected, a plan of action must be implemented which includes a notification process, flood watch procedures, a highway closure process, documentation of available detours, inspection procedures, assessment procedures, and a repair notification process.

The next section provides some general criteria for the selection of countermeasures for stream instability and scour. Then, the selection of countermeasures for specific stream instability and bridge scour problems is discussed.

3.2 CRITERIA FOR THE SELECTION OF COUNTERMEASURES

The selection of an appropriate countermeasure for a specific erosion or scour problem is dependent on factors such as the erosion or scour mechanism, stream characteristics, construction and maintenance requirements, potential for vandalism, and costs. Perhaps more important, however, is the effectiveness of the measure selected in performing the required function.

For example, protection of an existing bank line may be accomplished with revetments, spurs, retards, longitudinal dikes, or bulkheads (see Chapter 2 and Table 2.1). Spurs, longitudinal dikes, and area retardance structures can be used to establish a new flow path and channel alignment, or to constrict flow in a channel. Because of their high cost, bulkheads may be appropriate for use only where space is at a premium. Channel relocation may be used separately or in conjunction with other countermeasures to change the flow path and flow orientation.

3.2.1 Erosion Mechanism

Bank erosion mechanisms include surface erosion and/or mass wasting. Surface erosion is the removal of soil particles by the velocity and turbulence of the flowing water. Mass wasting is by slides, rotational slip, piping and block failure. In general slides, rotational slip and block failure result from the bank being undercut by the flow. Also, seepage force of the pore water in the bank is another factor that can cause surface erosion or mass wasting. The type of mechanism is determined by the magnitude of the erosive forces of the water, type of bed and bank material, vegetation, and bed elevation stability of the stream. These mechanisms are described in HDS 6 (Richardson et al. 2001) and HEC-20 (Lagasse et al. 2001a).

3.2.2 Stream Characteristics

Stream characteristics that influence the selection of countermeasures include (see also Table 2.1):

- Channel width
- Bank height
- Channel configuration
- Channel material
- Vegetative cover
- Sediment transport condition
- Bend radius
- Channel velocities and flow depth
- Ice and debris
- Floodplain characteristics

Channel Width. Channel width influences the use of bendway weirs and other spur-type countermeasures. On smaller streams (250 ft (<75 m) wide), flow constriction resulting from the use of spurs may cause erosion of the opposite bank. However, spurs can be used on small channels where the purpose is to shift the location of the channel. Changes in channel width can influence contraction scour and impact bridge pier and abutment countermeasures.

Bank Height. Low banks (<10 ft (3 m)) may be protected by any of the countermeasures, including bulkheads. Medium height banks (from 10 to 20 ft (3 to 6 m)) may be protected by revetment, retardance structures, spurs, and longitudinal dikes. High banks (>20 ft (6 m)) generally require revetments used alone or in conjunction with other measures.

Channel Configuration. Spurs and jack fields have been successfully used as a countermeasure to control the location of the channel in meandering and braided streams. Also, bulkheads, revetments, and riprap have been used to control bank erosion resulting from stream migration. On anabranching streams, revetments, riprap, and spurs have been used to control bank erosion and channel shifting. Also, secondary or side channels that do not carry large flows can and have been closed off. In one case, HDS 6 reports that a large channel was closed off and revetment and riprap used to control erosion in the other channel (Richardson et al. 2001).

Channel Material. Spurs, revetments, riprap, jack fields, or check dams can be used in any type of channel material if they are designed correctly. However, jack fields should only be placed on streams that carry appreciable debris and sediment in order for the jacks to cause deposition and eventually be buried. For channels in the sand size range the movement of bedforms (ripples, dunes, and antidunes) will influence the design of bridge pier and abutment scour countermeasures (see HEC-20 and HDS 6). Some countermeasures may be subject to abrasion and consequent failure from coarse bed load sediment.

Bank Vegetation. Vegetation such as willows can enhance the performance of structural countermeasures for stream instability and may, in some cases, reduce the level of structural protection needed. Meander migration and other bank erosion mechanisms are accelerated on many streams in reaches where vegetation has been cleared.

Sediment Transport. Sediment transport conditions can be described as regime, threshold, or rigid. Regime channel beds are those which are in motion under most flow conditions, generally in sand or silt-size noncohesive materials. Threshold channel beds have no bed material transport at normal flows, but become mobile at higher flows. They may be cut through cohesive or noncohesive materials, and an armor layer of coarse-grained material can develop on the channel bed. Rigid channel beds are cut through rock or boulders and rarely or never become mobile. In general, permeable structures will cause deposition of bed material in transport and are better suited for use in regime and some threshold channels than in rigid channel conditions. Impermeable structures are more effective than permeable structures in channels with little or no bed load, but impermeable structures can also be very effective in mobile bed conditions. Revetments can be effectively used with mobile or immobile channel beds. Live-bed and clear-water conditions must be considered when estimating contraction scour and will influence the design of pier scour countermeasures (Richardson and Davis 2001).

Bend Radius. Bend radius affects the design of stream instability countermeasures, because some countermeasures will only function properly in long or moderate radius bends. Thus, the cost per meter (foot) of bank protection provided by a specific countermeasure may differ considerably between short-radius and longer radius bends. Impinging flow and increased shear stress in short radius bends also affect the stability of scour countermeasures.

Channel Velocities and Flow Depth. Channel hydraulics affect the selection and design of all countermeasures. For stream instability countermeasures, structural stability and induced scour must be considered. Some of the permeable flow retardance measures may not be structurally stable and countermeasures which utilize piles may be susceptible to scour

failure in high velocity environments. Velocity and depth have a direct influence on the design of bridge pier and abutment scour countermeasures (see Chapter 4).

Ice and Debris. Ice and debris can damage or destroy any countermeasure and should always be considered during the selection process. On the other hand, the performance of some permeable spurs and area retardance structures is enhanced by debris where debris accumulation induces additional sediment deposition.

Floodplains. In selecting countermeasures for stream stability and scour, the amount of flow on the floodplain is an important factor. For example, if there is appreciable overbank flow, then the use of guide banks to protect abutments should be considered. Also, spurs perpendicular to the roadway approach embankment may be required to control erosion.

3.2.3 Construction and Maintenance Requirements

Standard requirements regarding construction or maintenance such as the availability of materials, construction equipment requirements, site accessibility, time of construction, contractor familiarity with construction methods, and a program of regular maintenance, inspection, and repair are applicable to the selection of appropriate countermeasures. Additional considerations for countermeasures located in stream channels include: constructing and maintaining a structure that may be partially submerged at all times, the extent of bank or channel bed disturbance which may be necessary, and the desirability of preserving streambank vegetative cover to the extent practicable.

3.2.4 Vandalism

Vandalism is always a maintenance concern since effective countermeasures can be made ineffective by vandals. Documented vandalism includes dismantling of devices, burning, and cutting or chopping with knives, wire cutters, and axes. Countermeasure selection or material selection for construction may be affected by concerns of vandalism. For example, rock-filled baskets (gabions) may not be appropriate in some urban environments.

3.2.5 Countermeasure Selection Based on Cost

Cost comparisons should be used to study alternative countermeasures with an understanding that the measures were installed under widely varying stream conditions, that the conservatism (or lack thereof) of the designer is not accounted for, that the relative effectiveness of the measures cannot be quantitatively evaluated, and that some measures included in the cost data may not have been fully tested by floods.

Life-cycle cost information is difficult to quantify. Initial construction costs are relatively easy to develop; however, even for a specific countermeasure, these costs can vary widely depending on regional availability of materials, site conditions, and access constraints. Therefore, a countermeasure type can be very cost effective in one locale and prohibitively expensive in another. Extending these issues to life-cycle maintenance requirements requires an even broader set of assumptions. Riprap, for example, is a standard countermeasure type in many states; however, alternatives to riprap may need to be investigated because of cost and availability limitations. The risks and consequences of failure at any given site further complicate the issue. Life-cycle costs were , however, the focus of a countermeasure selection methodology for a range of bridge pier scour countermeasures.

A selection methodology was developed under NCHRP Project 24-07(2) (Lagasse et al. 2007) to provide a quantitative assessment of the suitability of six armoring-type pier scour countermeasures based on selection factors that consider river environment, construction considerations, maintenance, performance, and estimated life-cycle cost. With the exception of life-cycle costs, the methodology analyzes the design factors by stepping the user through a series of decision branches, ultimately resulting in a site-specific numerical rating for each selection factor. Countermeasures evaluated by this methodology are:

- Standard (loose) riprap
- Partially grouted riprap
- Articulating concrete blocks
- Gabion mattresses
- Grout filled mattresses
- Grout filled bags

Five factors are used to compute a Selection Index (SI) for each countermeasure:

- S1: Bed material size and transport
- S2: Severity of debris or ice loading
- S3: Constructability constraints
- S4: Inspection and maintenance requirements
- LCC: Life-cycle costs

The Selection Index is calculated as:

$$SI = (S1 \times S2 \times S3 \times S4) / LCC \quad (3.1)$$

The countermeasure that has the highest value of SI is considered to be most appropriate for a given site, based not only on its suitability to the specific riverine and project site conditions, but also in consideration of its economy. The approach is sensitive to assumptions regarding initial construction cost, remaining service life, assumed frequency of maintenance events, and extent of maintenance required. Each of these factors requires experience and engineering judgment, as well as site- or region-specific information on the cost of materials and delivery, construction practices, and prevailing labor rates. **It should be noted that the methodology can be used simply to rank the countermeasures in terms of suitability alone by assuming that the life cycle costs are the same for all countermeasures.**

The following sections describe the five factors that comprise the methodology. Flow charts illustrating selection factors S1 – S4 are included in Appendix C.

Bed Material. Bed material is included as a selection factor for two reasons. Abrasion caused by the transport of coarse bed sediments will cause the wire mesh on a gabion mattress to weaken and break, whereas other countermeasure types are relatively resistant to degradation by abrasion. For this reason, when bed material is greater than 2 mm, gabion mattresses are eliminated from the selection process. Bed material size also assists in distinguishing whether dune-type bedforms are anticipated. Grout filled mats are susceptible to failure in the presence of bedforms because the mats do not articulate as well as other countermeasures. When the bed material is less than 2 mm and bedforms are not anticipated, all countermeasures included in the selection process are deemed equally viable.

Ice and/or Debris Loading. Debris in this context is considered floating material such as logs, other woody materials, man-made materials that are typically transported during floods, or ice. The intent of this selection factor is to recognize that high debris loads can be detrimental to gabion mattresses, as indicated in the countermeasure selection matrix in Chapter 2. When a user indicates that anticipated debris loading is high, gabion mattresses receive a low rating of "1" but are not eliminated from the selection process. When debris loading is not anticipated, all countermeasures included in the selection process are deemed equally viable.

Construction Constraints. Construction constraints take into account the different needs and challenges required for placing a countermeasure in the dry versus installation underwater or, in the extreme case, in flowing water. All ratings that consider construction constraints are divided into two categories: piers that have shallow footings versus piers that are more deeply embedded. This results from the fact that riprap-based countermeasures are typically thicker than alternative countermeasures, and they require pre-excavation that may undermine the footer.

In addition, the requirements for specialized equipment are addressed. For example, the equipment requirements, placement techniques, and construction QA/QC requirements for partially grouted riprap are straightforward for working in the dry; however, placement underwater requires construction equipment and placement technologies that are much more sophisticated. Subgrade preparation requirements and placement tolerances also vary among countermeasure types. For example, a relatively thin veneer of articulating concrete blocks requires finer grading techniques than an equivalent, and much thicker, riprap layer.

Working beneath a bridge deck that affords little headroom will dictate the type of equipment that can be used for countermeasure installation. Lastly, alternative placement techniques, particularly for rock riprap, typically dictate the strength requirements for geotextiles in order to meet criteria for geotextile survivability during installation.

The decision box for flow velocity is intended to reflect the relative difficulty in placing a mattress system, such as ACBs, gabion mattresses, or grout mattresses under fast flowing water $V > 4$ ft/s (1.2 m/s). When the countermeasure does not need to be placed under water and access for construction equipment of all types is good, all countermeasures included in the selection process are deemed equally viable.

Inspection and Maintenance. Inspection and maintenance guidelines vary greatly among countermeasure types. Underwater or buried installations require different considerations to ensure that the countermeasure can be adequately inspected, compared to surficial treatments in ephemeral or intermittent stream environments. The numerical values assigned to this selection factor reflect the relative difficulty of repairing and/or replacing "manufactured" countermeasures, such as ACBs, gabion mattresses, and grout mattresses, versus the relative ease of adding more riprap stone.

The maintenance required for gabion mattresses as presented may be somewhat higher than for other forms of revetment because the wire mesh used to construct the gabion is susceptible to vandalism. When the countermeasure can be inspected and maintenance performed in the dry, all countermeasures included in the selection process are deemed equally viable.

Life-Cycle Costs. The Selection Index calculation is similar to the "Risk Priority Number" method suggested by Johnson and Niezgodá (2004). Johnson and Niezgodá use the concept of "risk categories" in contrast to this selection methodology concept of "suitability categories" to relate various factors. Both methods represent relatively simple techniques for selecting pier scour countermeasures. However, due to the complexity of determining costs associated with countermeasure design and implementation, Johnson and Niezgodá discussed life cycle costs but did not include those costs in the scope of their procedure.

Without consideration of life-cycle cost, the suitability of a countermeasure is dictated solely by the environment of the river and its interaction with the bridge structure, combined with the strengths and vulnerabilities of the countermeasure. This selection methodology attempts to simplify the life-cycle cost estimation process through a series of spreadsheets that assist the user in evaluating regional availability of materials, installation expenses, and an estimation of maintenance based on experience and engineering judgment (see Appendix C).

Life-cycle cost information can be difficult to quantify. Initial construction costs are relatively easy to develop; however, even for a specific countermeasure, these costs can vary widely depending on regional availability of materials, site conditions, and access or constructability constraints. Therefore, a particular countermeasure might be very cost effective in one locale and prohibitively expensive in another. Extending these issues to life-cycle maintenance requires an even broader set of assumptions. This portion of the assessment attempts to ease this process for the practitioner by providing templates for cost estimation.

Estimating life-cycle costs for pier scour countermeasures requires consideration of three major components:

1. Initial construction materials and delivery costs
2. Initial construction installation costs associated with labor and equipment
3. Periodic maintenance during the life of the installation

Each of the above components is comprised of multiple elements, which differ among the various countermeasure types. For example, quantities and unit costs of alternative materials will vary depending on the specific project conditions, as well as local and regional factors. Experience with these factors, as well as project-specific knowledge of the bridge site, are required in order to be as accurate as practicable when using this selection methodology.

The following issues should be considered when developing life-cycle cost estimates:

- Availability of materials of the required size and weight
- Haul distance
- Site access
- Equipment requirements for the various countermeasures being considered
- Construction underwater vs. placement in the dry
- Environmental and water quality issues and permitting requirements
- Habitat and/or migration issues for threatened and endangered species
- Traffic control during construction and/or maintenance activities
- Local labor rates
- Construction using in-house resources vs. outside contract
- Design life of the installation
- Anticipated frequency and extent of periodic maintenance and repair activities

Quantifying each of these factors requires experience and engineering judgment. For this reason, these variables are user inputs in the life cycle cost worksheets referenced in Appendix C. **The default values that are provided in the Excel spreadsheet program can and should be changed by the user to reflect both site-specific and state or regional conditions.** For access to the Excel spreadsheet, see Forward to Lagasse et al. 2007.

3.2.6 Countermeasure Selection Based on Risk

As suggested by the various scenarios described in Chapter 2, a risk-based analysis may be necessary to develop the plan of action for multiple bridges with scour critical ratings. The level of response and the actions taken will be different from one scour critical bridge to the next. Given limited resources and multiple options, it is up to the interdisciplinary team to formulate the best alternative for any given plan of action considering all available information.

The need to evaluate countermeasure alternatives considering economics and risk led to the development of a systematic, risk-based method to determine the level of resources appropriate for protection of a bridge that is scour critical but has a limited life before scheduled replacement (Pearson et al. 2000). This method determines the optimum level of protection for the bridge and the maximum expenditures that should be accepted to increase the level of protection. An overview of the concepts involved in this approach is provided in this section. Equations to apply the method and an application example are provided in Pearson et al. (2000).

The objectives of the risk-based approach to countermeasure selection are to:

- Identify bridges at risk from scour using data from the National Bridge Inventory (NBI)
- Examine the economic feasibility of scour countermeasure alternatives

For convenience, NBI data is used to estimate the relative risk of bridge failure due to scour, where risk is defined as the costs associated with bridge failure multiplied by the probability of failure. The NBI codes can be used to estimate both the cost of failure and the probability of failure as shown in Figure 3.1.

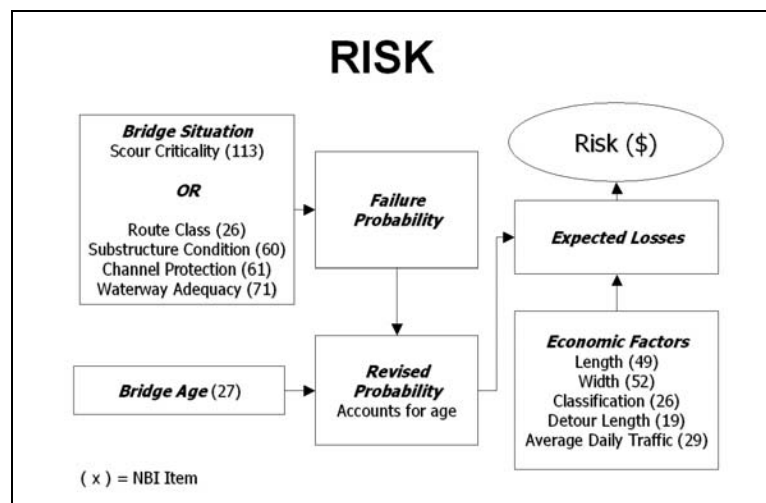

Figure 3.1. Risk-based approach using NBI data.

The failure probability can be derived from the NBI Item 113 coding or, alternatively, from a combination of route class, substructure condition, channel protection, and waterway adequacy. The failure probability can be adjusted based on bridge age (NBI Item 27). Economic factors that influence costs associated with bridge failure include: bridge length, width, and classification, detour length, and average daily traffic (ADT).

Thus, the risk (expected loss) calculated by this method is the product of the probability of scour failure (or heavy damage) and the economic losses associated with such an event. The year-to-year risk (expected loss) of scour failure associated with a bridge installation over water is determined by Equation 3.2.

$$\text{Risk (\$)} = KP [(\text{rebuild cost}) + (\text{running cost}) + \text{time cost}] \quad (3.2)$$

where:

- Risk (\$) = Risk of scour failure (annualized for 1 year given current physical condition)
- K = Risk adjustment factor based on foundation type and type of span (NBI Item 43), and
- P = Probability of failure each year (NBI Item 113 or Items 26, 60, 61, and 71)

Rebuild cost, running cost, and time cost can be developed from equations or graphs provided in Pearson et al. (2000).

With the risk of bridge failure established in terms of cost, the risk can be compared with the costs and benefits associated with a range of countermeasure alternatives. This can be done by balancing costs and risks by using a simple benefit/cost ratio, or by a net benefit analysis for candidate countermeasures. As noted by Pearson et al. (2000), balancing the costs and risks represents a traditional approach to risk management—finding the countermeasure cost that corresponds as closely as possible to the risk cost. This approach, however, hides the economic benefits offered by available countermeasures. Maximizing the net benefit illuminates the economic benefits of countermeasures but may result in countermeasure costs greater than necessary to achieve a particular protection goal. Maximizing the benefit/cost ratio offers the soundest economic approach to countermeasure selection since it results in the greatest countermeasure benefit per dollar spent. For an application of risk-based concepts, see Pearson et al. (2000).

3.3 COUNTERMEASURES FOR MEANDER MIGRATION

The best countermeasure against meander migration is to locate the bridge crossing on a relatively straight reach of stream between bends. At many such locations, countermeasures may not be required for several years because of the time required for the bend to move to a location where it becomes a threat to the highway facility. However, bend migration rates on other streams may be such that countermeasures will be required after a few years or a few flood events and, therefore, should be installed during initial construction [see HEC-20 (Lagasse et al. 2001a)] for further discussion of lateral channel instability, and NCHRP Report 533 (Lagasse et al. 2004) for a methodology for estimating rates of meander migration).

Stabilizing channel banks at a highway stream crossing can cause a change in the channel cross section and an increase in stream sinuosity upstream of the stabilized banks. Figure 3.2a illustrates a natural channel section in a bend with the deeper section at the outside of the bend and a gentle slope toward the inside bank resulting from point bar growth. Figure 3.2b illustrates the scour which results from stabilizing the outside bank of the channel and the resulting steeper slope of the point bar on the inside of the bend. This effect must be considered in the design of the countermeasure and the bridge (see Section 4.3.5). It should also be recognized that the thalweg location and flow direction can change as sinuosity upstream increases.

Figure 3.3a illustrates meander migration in a natural stream and Figure 3.3b, the effects of bend stabilization on upstream sinuosity. As sinuosity increases, meander radii will become smaller, deposition may occur because of reduced slopes, and the channel width-depth ratio may increase as a result of bank erosion and deposition, as at the bridge location shown in Figure 3.3b. Ultimately, cutoffs can occur. These changes can also result in hydraulic problems downstream of the stabilized bend.

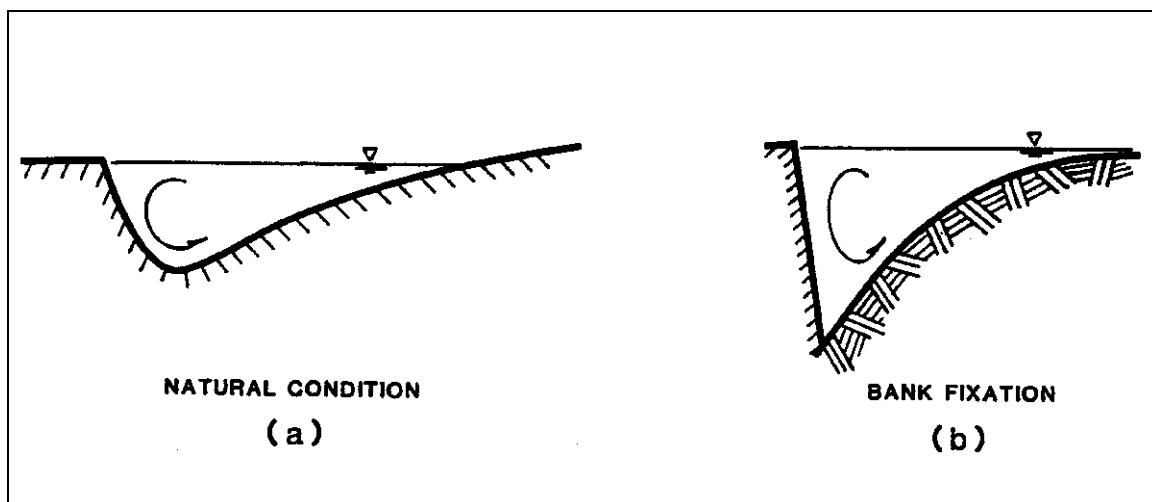

Figure 3.2. Comparison of channel bend cross sections (a) for natural conditions, and (b) for stabilized bend (after Brown 1985).

Countermeasures for meander migration include those that:

- Protect an existing bank line
- Establish a new flow line or alignment
- Control and constrict channel flow

The classes of countermeasures identified for bank stabilization and bend control are bank revetments, spurs, bendway weirs, longitudinal dikes, vane dikes, bulkheads, and channel relocations. Also, a carefully planned cutoff may be an effective way to counter problems created by meander migration. These measures may be used individually or in combination to combat meander migration at a site. Some of these countermeasures are also applicable to bank erosion from causes other than bend migration.

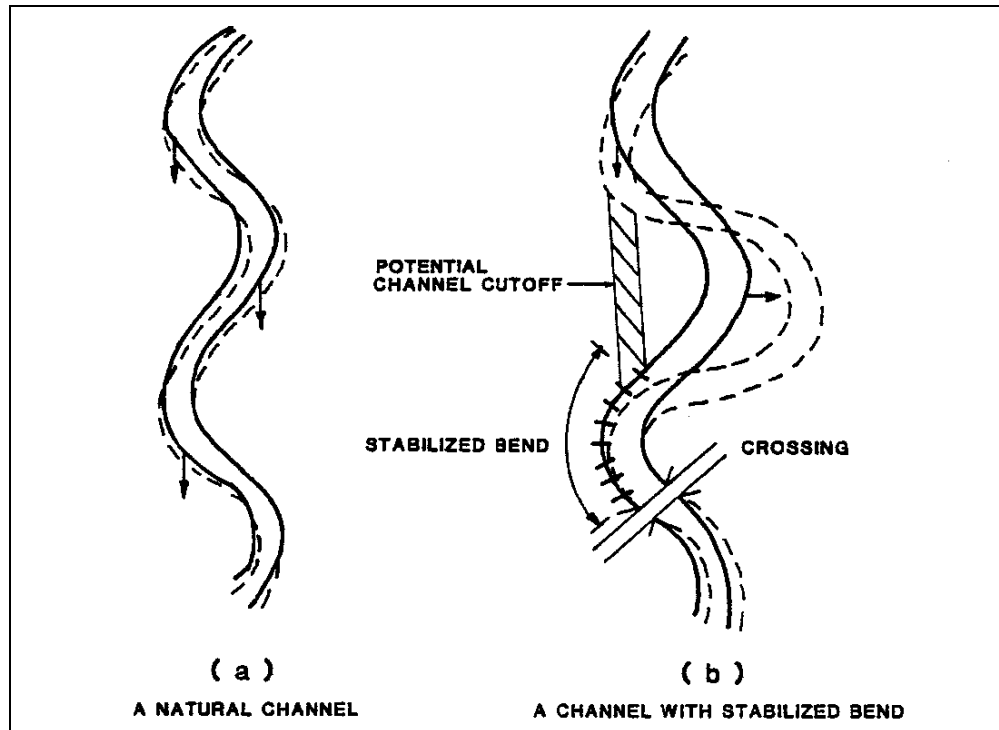

Figure 3.3. Meander migration in (a) a natural channel, and (b) a channel with stabilized bend (after Brown 1985).

3.4 COUNTERMEASURES FOR CHANNEL BRAIDING AND ANABRANCHING

Channel braiding occurs in streams with an overload of sediment, causing deposition and aggradation. As aggradation occurs, the slope of the channel increases, velocities increase, and multiple, interconnected channels develop. The overall channel system becomes wider and multiple channels are formed as bars of sediment are deposited in the main channel.

Braiding can also occur where banks are easily eroded and there is a large range in discharge. The channel becomes wider at high flows, and low-flow forms multiple interconnected channels. In an anabranching stream, flow is divided by islands rather than bars, and the anabranching channels are more permanent than braided channels and generally convey more flow.

A meandering stream may change to a braided stream if the slope is increased by channel straightening or the dominant discharge is increased. Lane's relation may be used to determine if there can be a shift from a meandering channel to a braided one. If, after a change in discharge or slope the stream still plots in the meandering zone, then it will likely remain a meandering stream. However, if it moves closer to or into the braided zone, then the stream may become braided (see HEC-20).

Braided channels change alignment rapidly, and are very wide and shallow even at flood flow. They present problems at bridge sites because of the high cost of bridging the complete channel system, unpredictable channel locations and flow directions, difficulties with eroding channel banks, and in maintaining bridge openings unobstructed by bars and islands.

Countermeasures used on braided and anabranching streams are usually intended to confine the multiple channels to one channel. This tends to increase the sediment transport capacity in the principal channel and encourage deposition in secondary channels. These measures usually consist of dikes constructed from the margins of the braided zone to the channel over which the bridge is constructed. Guide banks at bridge abutments (Design Guideline 15) in combination with revetment on highway fill slopes (Design Guideline 4), riprap on highway fill slopes only, and spurs (Design Guideline 2) arranged in the stream channels to constrict flow to one channel have also been used successfully.

Since anabranches are permanent channels that may convey substantial flow, diversion and confinement of an anabranching stream is likely to be more difficult than for a braided stream. The designer may be faced with a choice of either building more than one bridge, building a long bridge, or diverting anabranches into a single channel.

3.5 COUNTERMEASURES FOR DEGRADATION AND AGGRADATION

Bed elevation instability problems are common on alluvial streams. Degradation in streams can cause the loss of bridge piers in stream channels and can contribute to the loss of piers and abutments located on caving banks. Aggradation causes the loss of waterway opening in bridges and, where channels become wider because of aggrading streambeds, overbank piers and abutments can be undermined. At its worst, aggradation may cause streams to abandon their original channels and establish new flow paths which could isolate the existing bridge (see HEC-20 for further discussion of vertical channel instability).

3.5.1 Countermeasures to Control Degradation

Countermeasures used to control bed degradation include check dams and channel linings. Check-dams and structures which perform functions similar to check-dams include drop structures, cutoff walls, and drop flumes. A check-dam is a low dam or weir constructed across a channel to prevent upstream degradation (Design Guideline 3).

Channel linings of concrete and riprap have proved unsuccessful at stopping degradation. To protect the lining, a check-dam may have to be placed at the downstream end to key it to the channel bed. Such a scheme would provide no more protection than would a check dam alone, in which case the channel lining would be redundant.

Bank erosion is a common hydraulic hazard in degrading streams. As the channel bed degrades, bank slopes become steeper and bank caving failures occur. The USACE found that longitudinal stone dikes, or rock toe-dikes (see Chapter 8), provided the most effective toe protection of all bank stabilization measures studied for very dynamic and/or actively degrading channels.

The following is a condensed list of recommendations and guidelines for the application of countermeasures at bridge crossings experiencing degradation:

- Check-dams or drop structures are the most successful technique for halting degradation on small to medium streams.
- Channel lining alone may not be a successful countermeasure against degradation problems.
- Riprap on channel banks and spill slopes will fail if unanticipated channel degradation occurs.

- Successful pier protection involves providing deeper foundations at piers and pile bents.
- Jacketing piers with steel casings or sheet piles has also been successful where expected degradation extends only to the top of the original foundation.
- The most economical solution to degradation problems at new crossing sites on small to medium size streams is to provide adequate foundation depths. Adequate setback of abutments from slumping banks is also necessary.
- Rock-and-wire mattresses are recommended for use only on small (100 ft [<30 m]) channels experiencing lateral instability and little or no vertical instability.
- Longitudinal stone dikes placed at the toe of channel banks are effective countermeasures for bank caving in degrading streams. Precautions to prevent outflanking, such as tiebacks to the banks, may be necessary where installations are limited to the vicinity of the highway stream crossing.

3.5.2 Countermeasures to Control Aggradation

Currently, measures used in attempts to alleviate aggradation problems at highways include channelization, debris basins, bridge modification, and/or continued maintenance, or combinations of these. Channelization may include dredging and clearing channels, constructing small dams to form debris basins, constructing cutoffs to increase the local slope, constructing flow control structures to reduce and control the local channel width, and constructing relief channels to improve flow capacity at the crossing. Except for debris basins and relief channels, these measures are intended to increase the sediment transport capacity of the channel, thus reducing or eliminating problems with aggradation. Cutoffs must be designed with considerable study as they can cause erosion and degradation upstream and deposition downstream. These studies would involve the use of sediment transport relations given in HDS 6 (Richardson et al. 2001) or the use of sediment transport models such as BRI-STARS (Molinas 1990) or HEC-6 (USACE 1993). The most common bridge modifications are increasing the bridge length by adding spans and increasing the effective flow area beneath the structure by raising the bridge deck.

A program of continuing maintenance has been successfully used to control problems at bridges on aggrading streams. In such a program, a monitoring system is set up to survey the affected crossing at regular intervals. When some pre-established deposition depth is reached, the bridge opening is dredged or cleared of the deposited material. In some cases, this requires clearing after every major flood. This solution requires surveillance and dedication to the continued maintenance of an adequate waterway under the bridge. Otherwise, it is only a temporary solution. A debris basin or a deeper channel upstream of the bridge may be easier to maintain. Continuing maintenance is not recommended if analysis shows that other countermeasures are practicable.

Over the short term, maintenance programs prove to be very cost effective when compared with the high cost of channelization, bridge alterations, or relocations. When costs over the entire life of the structure are considered, however, maintenance programs may cost more than some of the initially more expensive measures. Also, the reliability of maintenance programs is generally low because the programs are often abandoned for budgetary or priority reasons. However, a program of regular maintenance could prove to be the most cost efficient solution if analysis of the transport characteristics and sediment supply in a stream system reveals that the aggradation problem is only temporary (perhaps the excess sediment supply is coming from a transient land use activity such as logging) or will have only minor effects over a relatively long period of time.

An alternative similar to a maintenance program which could be used on streams with persistent aggradation problems, such as those on alluvial fans, is the use of controlled sand and gravel mining from a debris basin constructed upstream of the bridge site. Use of this alternative would require careful analysis to ensure that the gravel mining did not upset the balance of sediment and water discharges downstream of the debris basin. Excessive mining could induce degradation downstream, potentially impacting the bridge or other structures.

The following is a list of guidelines regarding aggradation countermeasures:

- Extensive channelization projects have generally proven unsuccessful in alleviating general aggradation problems, although some successful cases have been documented. A sufficient increase in the sediment carrying capacity of the channel is usually not achieved to significantly reduce or eliminate the problem. Channelization should be considered only if analysis shows that the desired results will be achieved.
- Alteration or replacement of a bridge is often required to accommodate maximum aggradation depths.
- Maintenance programs have been unreliable, but they provide the most cost-effective solution where aggradation is from a temporary source or on small channels where the problem is limited in magnitude.
- At aggrading sites on wide, shallow streams, spurs or dikes with flexible revetment have been successful in several cases in confining the flow to narrower, deeper sections.
- A debris basin and controlled sand and gravel mining might be the best solution on alluvial fans (see HEC-20) and at other crossings with severe problems.

3.6 SELECTION OF COUNTERMEASURES FOR SCOUR AT BRIDGES

The selection of an appropriate countermeasure for scour at a bridge requires an understanding of the erosion mechanism producing the specific scour problem. For example, contraction scour results from a sediment imbalance across most or all of the channel, while local scour at a pier or abutment results from the action of vortices at an obstruction to the flow. Degradation is a component of total scour, but is considered a channel instability problem (see Section 3.5). Since the selection of a countermeasure depends on the type of scour involved, this section provides a brief overview of the principal scour components.

Scour is the result of the erosive action of running water, excavating and carrying away material from the bed and banks of streams. Different materials scour at different rates. Loose granular soils are rapidly eroded under water action while cohesive or cemented soils are more scour-resistant. However, ultimate scour in cohesive or cemented soils can be as deep as scour in sand-bed streams. Scour will reach its maximum depth in sand and gravel bed materials in hours; cohesive bed materials in days; glacial tills, poorly cemented sand stones and shales in months; hard, dense and cemented sandstone or shales in years; and granites in centuries. Massive rock formations with few discontinuities can be highly resistant to scour and erosion during the lifetime of a typical bridge [see HEC-18 (Richardson and Davis 2001) for detailed discussion and equations for calculating all bridge scour components].

Designers and inspectors need to carefully study site-specific subsurface information in determining scour potential at bridges, giving particular attention to foundations on rock.

Total Scour. Total scour at a highway crossing is comprised of three components. These components are:

- Aggradation and Degradation. These are long-term streambed elevation changes due to natural or human-induced causes within the reach of the river on which the bridge is located (see Section 3.5).
- Contraction Scour. This type of scour involves the removal of material from the bed and banks across all or most of the width of a channel. Most commonly, this scour is the result of a contraction of the flow by the approach embankments to the bridge encroaching onto the floodplain and/or into the main channel which causes an increase in transport of the bed material in the bridge cross section.
- Local Scour. This scour occurs around piers, abutments, spurs, and embankments and is caused by the acceleration of the flow and the development of vortex systems induced by these obstructions to the flow.

In addition to the types of scour mentioned above, lateral migration of the stream may also erode the approach roadway to the bridge or change the total scour by changing the angle of the flow in the waterway at the bridge crossing. Factors that affect lateral migration and the stability of a bridge are the geomorphology of the stream, location of the crossing on the stream, flood characteristics, and the characteristics of the bed and bank materials (see HEC-20).

3.6.1 Countermeasures for Contraction Scour

Severe contraction of flow at highway stream crossings has resulted in numerous bridge failures at abutments, approach fills, and piers from contraction scour. Design alternatives to decrease contraction scour include longer bridges, relief bridges on the floodplain, superstructures at elevations above flood stages of extreme events, and a crest vertical profile on approach roadways to provide for overtopping during floods exceeding the design flood event (see HEC-20). These design alternatives are integral features of the highway facility which reduce the contraction at bridges and, therefore, reduce the magnitude of contraction scour.

The elevation of bridge superstructures is recognized as important to the integrity of the bridge because of hydraulic forces that may damage the superstructure. These include buoyancy and impact forces from ice and other floating debris (see HEC-18). Contraction scour is another consideration in setting the superstructure elevation. When the superstructure of a bridge becomes submerged or when ice or debris lodged on the superstructure causes the flow to contract, flow may be accelerated and more severe scour can occur. For this reason, where contraction scour is of concern, bridge superstructures should be located with clearance for debris, and, if practicable, above the stage of floods larger than the design flood.

Another design feature which should be considered relative to contraction scour is the effective depth of the superstructure. Present day superstructures often include bridge railings which are solid parapets. These increase the effective depth of the superstructure and, thus, the importance of locating the bridge superstructure above high water with clearance for debris passage. It also increases the importance of alternate provisions for the passage of flood waters in the event of debris blockage of the waterway or superstructure submergence. Possible alternate provisions include relief bridges on the floodplain and a highway profile which provides for overtopping before the bridge superstructure begins to become submerged.

Similarly, pier design, span length, and pier location become more important contributors to contraction scour where debris can lodge on the piers and further contract flow in the waterway. In streams which carry heavy loads of debris, longer, higher spans and solid piers will help to reduce the collection of debris. Where practicable, piers should be located out of the main current in the stream, i.e., outside the thalweg at high flow. There are numerous locations where piers occupy a significant area in the stream channel and contribute to contraction scour, especially where devices to protect piers from ship traffic are provided.

The principal countermeasure used for reducing the effects of contraction is revetment on channel banks and fill slopes at bridge abutments (Design Guidelines 4 and 14). Additional countermeasures used to reduce flow contraction include measures which retard flow along highway embankments on floodplains. Flow along highway fills usually intersects with flow within bridge openings at large angles. This causes additional contraction of the flow, vortices, and turbulence which produce local scour. The contraction of flow can be reduced by using spurs on the upstream side of the highway embankment to retard flow parallel with the highway (Bradley 1978).

Similarly, guide banks (also referred to as spur dikes) at bridge abutments can improve the alignment of the flow in the bridge opening. They reduce contraction scour because they increase the efficiency of the bridge opening. The primary purpose of guide banks, however, is to reduce local scour at abutments (Design Guideline 15).

The potential for undesired effects from stabilizing all or any portion of the channel perimeter at a contraction should be considered. Stabilization of the banks may only result in exaggerated scour in the streambed near the banks or, in a relatively narrow channel, across the entire channel. Stabilization of the streambed may also result in exaggerated lateral scour in any size stream. Stabilization of the entire stream perimeter may result in downstream scour or failure of some portion of the countermeasures used on either the streambed or banks.

3.6.2 Countermeasures for Local Scour

Local scour occurs at bridge piers and abutments. In general, design alternatives against structural failure from local scour consist of measures which reduce scour depth, such as pier shape and orientation, and measures which retain their structural integrity after scour reaches its maximum depth, such as placing foundations in sound rock and using deep piling. Countermeasures which can reduce the risk from local scour include placing armor (e.g., riprap) at the structure or installing monitoring devices.

Abutments. Countermeasures for local scour at abutments consist of measures which improve flow orientation at the bridge end and move local scour away from the abutment, as well as revetments and riprap placed on spill slopes to resist erosion.

Guide banks are earth or rock embankments placed at abutments. Flow disturbances, such as eddies and cross-flow, will be eliminated where a properly designed and constructed guide bank is placed at a bridge abutment. Guide banks also protect the highway embankment, reduce local scour at the abutment and adjacent piers, and move local scour to the upstream end of the guide bank (Design Guideline 15).

Local scour also occurs at abutments as a result of expanding flow downstream of the bridge, especially for bridges on wide, wooded floodplains that have been cleared for construction of the highway. Short guide banks extending downstream of the abutment to the tree line will move this scour away from the abutment, and the trees will retard velocities so that flow redistribution can occur with minimal scour.

The effectiveness of guide banks is a function of stream geometry, the quantity of flow on the floodplain, and the size of bridge opening. A typical guide bank at a bridge opening is shown in Figure 3.4.

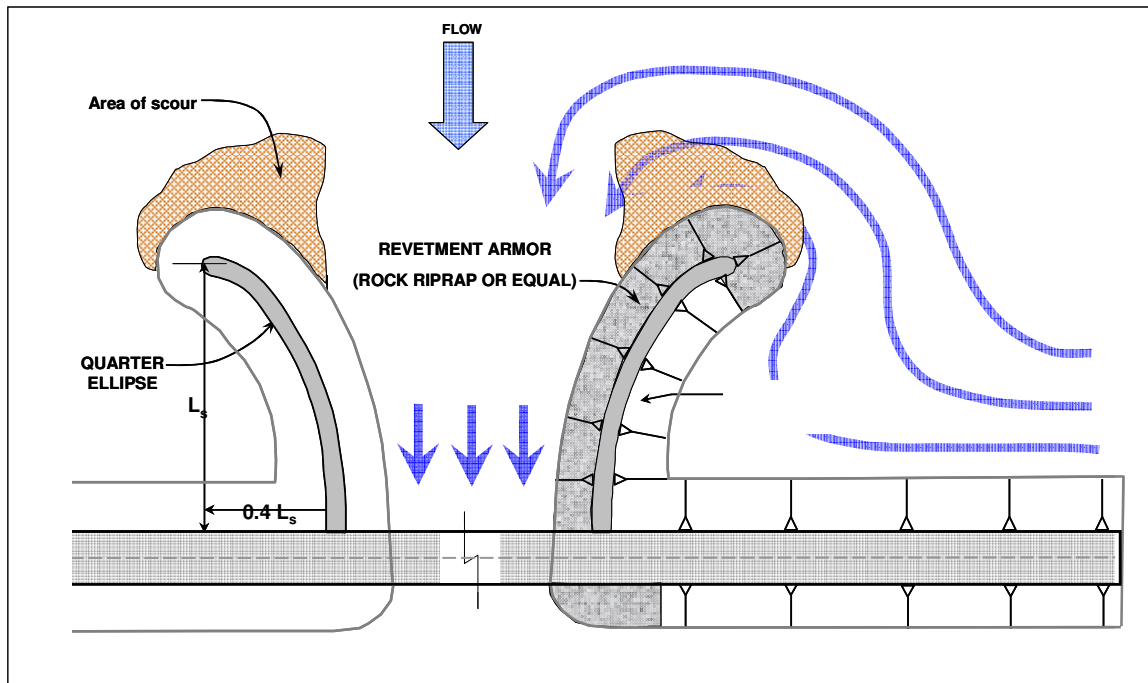

Figure 3.4. Typical guide bank layout (after Bradley 1978).

Other countermeasures have been successfully used to inhibit scour at abutments where the abutment is located at the streambank or within the stream channel. These measures include dikes to constrict the width of braided streams and retards to reduce velocities near the streambank.

Piers. Three basic methods may be used to prevent damage from local scour at piers. The first method is to place the foundation of the structure at such a depth that the structural stability will not be at risk with maximum scour. This must be done on all new or replacement bridges (Richardson and Davis 2001). The second method (for existing bridges) is to provide protection at or below the streambed to inhibit the development of a scour hole. The third measure is to prevent erosive vortices from forming or to reduce their strength and intensity.

Streamlining the pier nose decreases flow separation at the face of the pier, reducing the strength of the horseshoe vortices which form at piers. Practical application of this principle involves the use of rounded or circular shapes at the upstream and downstream faces of piers in order to reduce the flow separation. However, flow direction can and does change with time and with stage on some streams. Piers oriented with flow direction at one stage or at one point in time may be skewed with flow direction at another. Also, flow direction changes with the passage of bed forms. In general, piers should be aligned with the main channel design flow direction and skew angles greater than 5 degrees should be avoided. Where this is not possible, a single cylindrical pier or a row of cylindrical columns will produce a lesser depth of local scour.

The tendency of a row of columns to collect debris should be considered. Debris can greatly increase scour depths. Webwalls have been used between columns to add to structural strength and to reduce the tendency to collect debris. Webwalls should be constructed at the elevation of stream flood stages which carry floating debris and extended to the elevation of the streambed. When installing a webwall as a countermeasure against debris, the potential for significantly increased scour depths should be considered if the approach flow might impinge on the wall at a high angle of attack.

Riprap is commonly used to inhibit local scour at piers at existing bridges. This practice is not recommended as an adequate substitute for foundations or piling located below expected scour depths for new or replacement bridges. It is recommended as a retrofit or a measure to reduce the risk where scour threatens the integrity of a pier (Design Guideline 11). The use of partially grouted riprap offers the opportunity to use smaller rock for pier scour protection (Design Guideline 12), and geotextile sand containers can provide a methodology to install an appropriate filter in a pier scour hole in flowing water (see Section 5.4.2 and Design Guideline 11). A comprehensive selection methodology for pier scour countermeasures is introduced in Section 3.2.6.

The practice of heaping stones around a pier is not recommended because experience has shown that continual replacement is usually required. Success rates have been better with alluvial bed materials where the top of the riprap was placed at or below the elevation of the streambed.

Piles (sheet, H beams or concrete) have been successfully used as a retrofit measure to lower the effective foundation elevation of structures where footings or pile caps have been exposed by scour. The piling is placed around the pile footings and anchored to the pile cap or seal to retain or restore the bearing capacity of the foundation. The increased mass of the retrofit pile will, however, produce a greater depth of scour.

Where sheet pile cofferdams are used during construction, the sheet piling should be removed or cut off below the level of expected contraction scour in order to avoid contributing to local scour. Cofferdams should not be much wider than the pier itself since the effect may be to greatly increase local scour depth. Leaving or removing cofferdams must be carefully evaluated because leaving a cofferdam that is higher than the contraction scour elevation may increase local scour depth. A study by Jones (1989) gives a method to evaluate the expected scour depths for cofferdams.

3.6.3 Monitoring

Monitoring or closing a bridge during high flows and inspection after the flood may be an effective countermeasure to reduce the risk from scour. However, monitoring of bridges during high flow may not reveal that they are about to collapse from scour. It also may not be practical to close the bridge during high flow because of traffic volume, no (or poor) alternate routes, the need for emergency vehicles to use the bridge, etc. Under these circumstances, scour countermeasures such as riprap could be installed. A countermeasure installed at a bridge to reduce the risk from scour along with monitoring during and inspection after high flows could provide for the safety of the public without closing the bridge (see Chapter 9).

CHAPTER 4

COUNTERMEASURE DESIGN CONCEPTS

4.1 COUNTERMEASURE DESIGN APPROACH

4.1.1 Investment in Countermeasures

At stream crossings, the objective of DOTs is to protect highway users and the investment in the highway facility, and to avoid causing damage to other properties, to the extent practicable. Countermeasures should be designed and installed to stabilize only a limited reach of stream and to ensure the structural integrity of highway components in an unstable stream environment. Countermeasures are often damaged or destroyed by the stream, and streambanks and beds often erode at locations where no countermeasure was installed. However, as long as the primary objectives are achieved in the short-term as a result of countermeasure installation, the countermeasure installation can be deemed a success. Therefore, the DOTs' interest in stream stability often entails long-term protection of costly structures by committing to maintenance, reconstruction, and installation of additional countermeasures as the responses of streams and rivers to natural and man-induced changes are identified.

While it is sometimes possible to predict that bank erosion will occur at or near a given location in an alluvial stream, one can frequently be in error about the exact location or magnitude of potential erosion. At some locations, unexpected lateral erosion occurs because of a large flood, a shifting thalweg, or from other actions of the stream or human activities. Where the investment in a highway crossing is not in imminent danger of being lost, it is often prudent to delay the installation of countermeasures until the magnitude and location of the problem becomes obvious.

Thus, for stream instability countermeasures, a "wait and see" attitude may constitute the most economical approach. Retrofitting can be considered sound engineering practice in many locations because the magnitude, location, and nature of potential instability problems are not always discernible at the design stage, and indeed, may take a period of several years to develop.

4.1.2 Service Life and Safety

A life-cycle concept, as applied to an erosion or scour countermeasure incorporates a host of factors into a framework for decision making considering initial design, construction, and long-term maintenance. These factors could include engineering judgment applied to design alternatives, materials availability and cost, installation equipment and practices, and maintenance assumptions (see Section 3.2.5).

When selecting a service life criterion for various types of countermeasures for transportation facilities, safety must be a primary consideration. For DOTs safety of the traveling public is the first priority when setting service-life standards for countermeasures. Concurrent goals are protection of public and private property, protection of fish and wildlife resources, and enhancement of environmental attributes (Lagasse et al. 2006).

Thus, service-life for a countermeasure installation should be based on the importance of the facility to the public, that is, the risk of losing the facility and how that loss may directly or indirectly affect the traveling public, as well as the difficulty and cost of future repair or replacement. The conditions that constitute an "end of service life" for a countermeasure installation are largely dependent on the confidence one has that a degraded condition will be detected and corrected in a timely manner (e.g., during a post-flood inspection). Generally, for facilities that are rarely checked or inspected a very conservative (i.e., shorter) service life would be appropriate, while a less conservative standard could be used for facilities that are inspected regularly.

Service life for a countermeasure installation can be considered a measure of the durability of the total, integrated bank, pier or abutment protection system. The durability of system components and how they function in the context of the overall design will determine the service life of an installation. The response of the system over time to typical stresses such as flow conditions (floods and droughts) or normal deterioration of system components must also be considered. Response to less typical (but plausible) stresses such as fire, vandalism, seismic activity or accidents may also affect service life. Finally, there may be opportunities for maintenance during the life cycle of the installation and, where such work does not constitute total reconstruction or replacement, maintenance should not be considered as the end of service life for the system. In fact, a life-cycle approach to maintenance may extend the service life of a countermeasure installation and reduce the total cost over the life of the project.

4.1.3 Design Approach

The design of any countermeasure for the protection of highway crossings requires the designer to be cognizant of the factors which affect stream stability and the morphology of the stream. In most cases, the installation of any countermeasure will cause the bed and banks to respond to the change in hydraulic conditions imposed by the countermeasure.

Thus, the analysis procedures outlined in HEC-20 (Lagasse et al. 2001a) are a necessary prerequisite to the detailed design of specific countermeasures. The goal in any countermeasure design is to achieve a response which is beneficial to the protection of the highway crossing and to minimize adverse effects either upstream or downstream of the highway crossing. An appropriate level of hydraulic analysis must support the design of any stream instability or bridge scour countermeasure. In general, a countermeasure should be designed to provide a level of protection commensurate with the design event for the structure involved (see Section 4.3).

The bridge scour and stream instability countermeasures matrix (Table 2.1) helps define the set of specific countermeasures that are best suited to specific site conditions. The countermeasures matrix is intended, primarily, to assist with the selection of an appropriate countermeasure. Consideration of potential environmental impacts, maintenance, construction-related activities, and legal aspects can be used to refine the selection. The final selection criteria, and perhaps the most important, are the initial and long-term costs. The countermeasure that provides the desired level of protection at the lowest total cost may be the "best" for a particular application.

The following principles should be followed in designing and constructing stream instability and bridge scour countermeasures:

- Initial and long-term cost should not exceed the benefits to be derived. Countermeasures to make the bridge safe from scour and stream instability should be used for important bridges on main roads and where the results of failure would be intolerable. Expendable works may be used where traffic volumes are light, alternative routes are available, and the risk of failure is acceptable.

- Designs should be based on studies of channel trends and processes and on experience with comparable situations. The environmental effects of the countermeasures on the channel both up- and downstream should be considered.
- Field reconnaissance by the designer is highly desirable and should include the watershed and river system up- and downstream from the bridge.
- Evaluation of time-sequenced aerial photography is a useful tool to detect long-term trends in river stability [see for example NCHRP Report 533 (Lagasse et al. 2004)].
- Soil and geotechnical characteristics of the site and their influence on countermeasure and filter design must be considered. This may include a geotechnical slope stability assessment, possibly under rapid drawdown conditions. This will require input from a licensed geotechnical engineer.
- The possibility of using physical model studies as a design aid should receive consideration at an early stage.
- Countermeasures must be inspected periodically after floods to check performance and modify the design, if necessary. The first design may require modification. Continuity in treatment, as opposed to sporadic attention, is advisable. The condition of the countermeasure should be documented with photographs to enable comparison of its condition from one inspection to another.
- In most cases, the countermeasure does not "cure" the instability or scour problem, and planning (funding) for continued maintenance of the countermeasure will be required.

In some cases, a combination of two or more countermeasures could be required due to site-specific problems or as a result of changing conditions after the initial installation. The great number of possible countermeasure combinations makes it impractical to suggest design procedures for combined countermeasures. However, combined countermeasures should complement each other. That is to say, the design of one countermeasure must not adversely impact on another or the overall protection of the highway crossing. The principles of river mechanics, as discussed in HDS 6 (Richardson et al. 2001) and HEC-20, coupled with sound engineering judgment should be used to design countermeasure strategies involving two or more countermeasures.

4.2 ENVIRONMENTAL PERMITTING

The environmental permitting process can have a significant effect on the planning, design and implementation of river engineering works. Often, permitting can become a lengthy process for the implementation of bridge scour and stream instability countermeasures. To expedite this process, a memorandum dated February 11, 1997, was prepared jointly by the U.S. Army Corps of Engineers (USACE) Directorate of Civil Works and the Federal Highway Administration (FHWA). The purpose of the memorandum is to facilitate timely decisions on permit applications for work associated with measures to protect bridges determined to be at risk as the result of scouring around their foundations. The USACE and FHWA consider this agreement essential to assure the safety of the traveling public while protecting the environment.

Recognizing the importance of protecting the foundations of our Nation's scour critical bridges with properly designed scour countermeasures and the need for environmentally sound projects, the FHWA and the USACE agree to work together with the bridge owners, in a cooperative effort, to plan ahead for managing projects that will need a USACE permit. A strong cooperative effort will aid in advanced planning to avoid and minimize environmental

impacts, and in identifying locations where mitigation may be appropriate. If the bridge foundation has been determined to be scour critical as part of the bridge owner's scour evaluation program, the USACE will give priority to the bridge owner's request for authorization for the installation of scour countermeasures. Bridge owners must provide the FHWA and USACE Districts advance notice of the proposed countermeasure design and construction schedule. The notice must include an evaluation of the environmental impacts of the proposed scour countermeasure and appropriate mitigation of unavoidable impacts to aquatic resources, including fisheries and wetlands. This will allow appropriate and timely cooperation on project reviews. The USACE will make the maximum use possible of forms of expedited authorization, such as nationwide permits and regional permits, and Letters of Permission and the use of FHWA's Categorical Exclusion when the condition of the bridge foundation meets the criteria for codes 0 through 4 for Item 113 (FHWA 1995).

4.3 HYDRAULIC ANALYSIS

4.3.1 Overview

To be successful, the design of any countermeasure must incorporate an appropriate level of hydraulic analysis. The hydraulic principles of open channel flow and fundamentals of alluvial channel flow are summarized in HDS 6 and hydraulic factors that influence stream stability are presented in HEC-20. In addition, HEC-20 provides a general solution approach which includes hydrologic and hydraulic analysis steps in a multi-level analysis procedure (see Figure 1.1). Finally, HEC-18 (Richardson and Davis 2001) provides references and discussion of the standard 1- and 2-dimensional hydraulic computer models used for riverine and tidal analyses.

Both physical hydraulic modeling in a laboratory and numerical computer modeling are among the standard techniques available to analyze the scour problem and design countermeasures. This section introduces the use of physical modeling for the design of scour and stream instability countermeasures. Guidance is also provided for the analysis of several complex hydraulic conditions applicable to countermeasure design: scour at both transverse structures (spurs, jetties, dikes, and guide banks), and longitudinal structures (bendway revetment and vertical walls). The concept of radial stress on a bend is introduced as a method to evaluate (or predict) countermeasure performance in an eroding bendway.

4.3.2 Physical Models

The use of physical models as a tool in hydraulic design is commonly accepted. Many hydraulic phenomena which occur in nature are too complex to be described by rigorous mathematical techniques and models are used as an alternative means of obtaining the information necessary to complete an efficient and satisfactory design. Even in relatively simple situations, such as the design of spillways or water diversion structures, it is often impossible to predict the exact nature of the flow patterns without conducting a model study (Sharp 1981).

A summary of the principles of physical modeling for both rigid-boundary and movable-bed river models can be found in Shen (1979) who notes that hydraulic modeling has contributed significantly to design of hydraulic structures, training of rivers, and basic hydraulic research. It is a common practice to conduct hydraulic model tests to verify or modify the design of prototype structures. Hydraulic model tests are particularly useful in the study of complex flow phenomena for which no completely satisfactory theoretical analysis is available.

Some hydraulic tests are rather routine; many others are complex. For simple situations, hydraulic model tests provide accurate information that can be applied directly to prototype situations. However, for complex situations, hydraulic modeling is still more of an art than a science (Shen 1979). The following comments summarize important considerations for applying a physical model to the design of hydraulic structures, including countermeasures for bridge scour and stream instability.

- A physical model is very useful in the study of characteristics of complex flow phenomena involving significant flow variations in all three dimensions where no theoretical analysis is available.
- Dimensional analysis and physical reasoning are essential approaches to the selection of the governing similarity criteria. If more than one similarity criterion are needed, extensive knowledge of the basic process under investigation is necessary to deal with the situation.
- If the prototype is large, a distorted model may be necessary. In a distorted model the vertical model scale is usually smaller than the horizontal scale.
- A movable bed model may be necessary if a significant 3-dimensional variation of sediment movement occurs in the prototype. Since movable bed model results are difficult to interpret, it can be advantageous to first investigate general flow variations in a fixed bed model.
- Verification of model results is absolutely necessary. Model results are usually verified with at least three flow conditions: high, medium, and low flow.
- In order to design a river model study correctly, one must decide the purpose of the model tests, know the principles of modeling thoroughly, and also have a thorough technical knowledge of hydraulics and river mechanics.

FHWA's "River Engineering for Highway Encroachments" (HDS 6) provides additional discussion of similitude for rigid-boundary and mobile-bed models.

A 1998 investigation of European practice for bridge scour and stream instability countermeasures (TRB 1999) concluded that in Europe it is much more likely that physical modeling, often in conjunction with computer modeling, will be used as an integral part of the hydraulic design process for bridge foundations and countermeasures than we are accustomed to in the United States. Government research agencies and private sector laboratories (e.g., Delft Hydraulics in the Netherlands) maintain extensive physical modeling capabilities for the following reasons: validation of computer modeling, fundamental research with respect to physical processes, and solving problems for which computers cannot presently be applied.

In a report on testing the effectiveness of scour countermeasures by physical modeling, the Federal Waterways Engineering and Research Institute (BAW) in Karlsruhe, Germany notes that the physical modeling of the scouring process at bridge piers is a proven method to get information about the size of the scour and the flow velocities generating the scour. On the basis of this information, appropriate countermeasures can be designed. The advantage of the physical model is its application on even the most complex pier geometries (Eisenhauer and Rossbach 1999).

At BAW, model tests were conducted for the piers of a new bridge over the Rhine River near Mannheim, Germany (Figure 4.1). Soon after the driving of sheet pile as a formwork for the lower part of the pier (pier width 36 ft (11 m) below mean water level and 18 ft (5.5 m) above mean water level) severe scouring of the river bed ($d_{50} = 8$ mm) occurred. As a consequence, the stability of the sheet pile formwork was endangered. An emergency countermeasure of placing riprap of 6-8 inches (15-20 cm) diameter into the scour hole did not stop local scouring; however, an additional cover layer of coarser stones (diameter 8 – 24 inches [20-60 cm]) was placed on top of the previous layer, stopping the erosion process at mean flow. A series of model tests were conducted in order to estimate the durability and stability of the emergency countermeasure for flood events. The tests proved the riprap to be stable even at flood stage while the scour was shifted away from the pier to the margin between the riprap and the sand of the natural river bed.

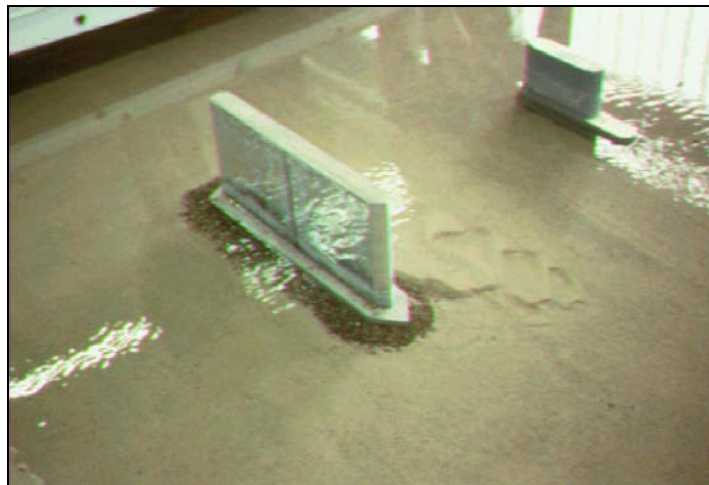

Figure 4.1. BAW laboratory, Karlsruhe, Germany, pier scour model of railway bridge over Rhine River near Mannheim (Eisenhauer and Rossbach 1999).

4.3.3 Scour at Transverse Structures

Several commonly used countermeasures for channel instability or scour protection project transversely into the flow (e.g., spurs, dikes, and jetties) or intercept overbank flow as it returns to the main channel (e.g., guide banks). Estimating scour at the nose of these structures is critical to successful design. Equation 4.1 is presented in HEC-18 as an alternative abutment scour equation when the projecting embankment/abutment length is large in relation to flow depth ($a/y_1 > 25$).

$$\frac{y_s}{y_1} = 4 F_r^{0.33} \quad (4.1)$$

where:

- y_s = Equilibrium depth of scour (measured from the mean bed level to the bottom of the scour hole), ft (m)
- y_1 = Average upstream flow depth in the main channel or on the overbank outside the influence of the structure, ft (m)
- a = Structure length projecting normal to the flow, ft (m)
- F_r = Upstream Froude Number outside the influence of the structure

This equation is based on field data on scour at the nose of rock spurs in the Mississippi River (obtained by the USACE) and is suggested here for estimating local scour at the nose of any transverse structure projecting into the flow.

For cases where the transverse structure length is small in comparison to flow depth ($a/y_1 \leq 25$) HDS 6 (see "Highways in the River Environment," 1990 Edition) presents the following equation for local live-bed scour in sand at a stable spill slope when the flow is subcritical:

$$\frac{y_s}{y_1} = 1.1 \left(\frac{a}{y_1} \right)^{0.4} F_r^{0.33} \quad (4.2)$$

Where the variables are defined as for Equation 4.1. This equation is suggested here for estimating local scour at the nose of a transverse structure projecting into the flow when the conditions for Equation 4.1 are not met.

4.3.4 Scour at Longitudinal Structures

Variations in bed elevation during flow events or after bank hardening can result in the undermining of bank protection structures including longitudinal structures. Therefore, methods are needed for estimating maximum scour in order to design stable bank protection. The following sections provide methods for estimating scour along longitudinal countermeasures such as bulkheads and vertical walls.

Scour with Flow Parallel to a Vertical Wall. The probable mechanism causing scour along a vertical wall when the flow is parallel to the wall is an increase in boundary shear stress produced by locally increased velocity gradients that result from the reduced roughness of the vertical wall, as compared to the natural channel. It is reasonable to conclude that this scour will continue until the local flow area has increased enough to reduce the local velocity, and hence the local boundary shear stress, to values typical of the rest of the channel cross section (RCE 1994).

The magnitude of boundary shear stress around the perimeter of a channel is not constant. In channels of uniform roughness, the boundary shear stress has a maximum value near the channel centerline, and a secondary peak about one-third of the way up the sideslope. On average, the maximum on the bottom is about 0.97 times the average boundary shear stress (e.g., as defined by γRS) for the cross section and the maximum on the side is about 0.76 times the average boundary shear stress. However, experimental data indicate a range of values, with maximum shear stresses as much as 1.6 times the average. In general, the boundary shear stress distribution is more uniform as the width to depth ratio increases.

Similar information is not available for channel cross sections of nonuniform roughness; however, reasonable conclusions can be drawn from intuitive arguments. For a straight channel with a vertical wall with smoother roughness than the rest of the channel along one side, the boundary shear stress distribution would be skewed towards the wall side of the channel. The sideslope peak value would be larger and could possibly be greater than the peak along the channel bed, which would also be shifted off the centerline location. These effects would be more pronounced in narrow channels and/or channels with steep sideslopes. As the channel gets wider, or the sideslope flattens, these effects would be diminished.

Insight on the magnitude of these effects can be obtained by considering local velocity conditions as determined by conveyance weighting concepts (see HEC-18 and HEC-20). The analysis assumes that the boundary roughness within the channel can be divided into

two distinct regions: one region defining the roughness of the channel banks and the other defining the roughness of the channel bottom (note that this division of roughness, while logical, is not always analytically useful as it can create numerical problems leading to errors in the computation of conveyance for the entire cross section).

For purposes of illustration, a wide, shallow natural channel has a uniform roughness with a Manning's n value of 0.03, but with a concrete vertical wall the n value of the bank region is reduced by a factor of two, to 0.015. Evaluation of the distribution of discharge by conveyance weighting shows that this reduction of "n" nearly doubles the conveyance, discharge, and velocity adjacent to the bank (i.e., next to the wall). Recognizing that boundary shear stress is proportional to velocity squared, this increase in velocity increases the boundary shear stress by a factor of 4.

Based on the experimental results for a uniform roughness channel, the maximum boundary shear stress along the vertical wall could be as much as 3 times the average boundary shear stress. However, this is not totally accurate given the simplistic assumptions made and the likely changes in the distribution pattern that would result under conditions produced by a vertical wall. Nonetheless, this simplified analysis suggests that significant increases in the boundary shear stress are possible adjacent to the wall.

To apply this concept, it is appropriate to define a shear stress multiplier that can be applied to the average boundary shear stress to define the locally increased boundary shear stress adjacent to a vertical wall. Based on the above argument, a shear stress factor of 3 is suggested. Recognizing that boundary shear stress is proportional to velocity squared, the reduction in velocity necessary to lower the shear stress to an acceptable value is defined by the inverse of the square root of the shear stress multiplier (0.577) for the shear stress factor of 3. For the reduction in velocity to occur, the flow area must then be increased by the inverse of this factor ($1/0.577 = 1.73$). For a vertical wall, this calculation simplifies to a unit width basis and the scour depth is a multiplier of the average flow depth ($0.73 y_1$).

It is important to understand that this provides a first approximation of the potential scour along a vertical wall due to flow parallel to the wall. Using this relation, the total scour along the wall due to parallel flow can be approximated as the sum of the above relation, which results from a differential in shear stress, plus scour associated with the passage of antidunes (see HDS 6). This results in the following relationship:

$$\frac{y_s}{y_1} = 0.73 + 0.14 \pi F_r^2 \quad (4.3)$$

where:

- y_s = Equilibrium depth of scour (measured from the mean bed level to the bottom of the scour hole), ft (m)
- y_1 = Average upstream flow depth in the main channel, ft (m)
- F_r = Upstream Froude Number

This equation is applicable only where parallel flow can be assured (e.g., vertical walls along both banks).

Scour with Flow Impinging at an Angle on a Vertical Wall. When an obstruction such as an abutment or vertical wall projects into the flow, the depth of scour at the nose or face of the obstruction can be estimated from Equation 4.1. Considering the physical configuration of the channels for which the data on which this relation is based, this can reasonably be

assumed to be the upper limit of the scour that could be expected for flow along a vertical wall when the flow impinges on the wall at an approximately 90° angle. The total scour along a vertical wall, thus, will vary as a proportion of that given by Equations 4.1 and 4.3. Assuming that the relative significance of the two scour mechanisms is related to the change in momentum associated with the change in flow direction from some angle θ relative to the wall, the two relations can be combined using a weighting factor based on the sine or cosine, respectively, of the angle of the flow to the wall (0° to 90°). The resulting relationship is given by (RCE 1994):

$$\frac{y_s}{y_1} = (0.73 + 0.14 \pi F_r^2) \cos \theta + 4 F_r^{0.33} \sin \theta \quad (4.4)$$

where:

θ = Angle between the impinging flow direction and the vertical wall

Scour Along a Vertical Wall Relative to Unconstrained Valley Width. The potential scour that could occur along a vertical wall due to changes in planform as the channel evolves can be estimated by combining Equation 4.4 with the relationships for ideal meander geometry (see HEC-20). Using these relationships, it can be shown that the maximum angle will vary from zero, when the width of the valley is constrained to the width of the channel, to approximately 71°, when the unconstrained valley width is approximately 3.5 times the width of the channel. These values are based on the assumption that the meander wavelength is 14 times the channel width. The resulting dimensionless scour depth as a function of the unconstrained valley width is plotted in Figure 4.2 for a range of Froude Numbers (F_r).

It is possible for the channel to impinge perpendicular to the wall due to local flow deflection or other local factors. For this case, the angle of impingement is no longer related to the valley width, and the maximum scour depth can best be estimated based strictly on Equation 4.1.

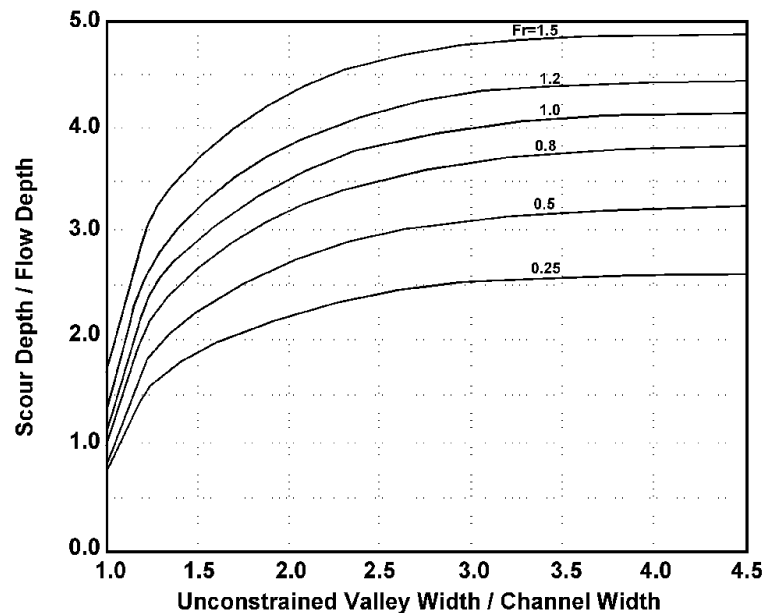

Figure 4.2. Scour along a vertical wall as a function of unconstrained valley width (RCE 1994).

In using Figure 4.2, it is important to recognize that the relationships are based on an assumed ideal meander geometry and scour relationships that, while they are the best available, are very approximate. Considering the extreme local variability that can occur in a given stream and the approximate nature of the relationships upon which these results are based, engineering judgment is critical in evaluating the reasonableness of the results for a specific problem. In particular, the potential for flow deflection and its effect on the angle of impingement on the wall should be considered and a conservatively large angle applied in Equation 4.4. If there is any reasonable possibility of flow perpendicular to the wall, an angle of 90° (thus, Equation 4.1) is recommended. When the results of this analysis are used to design the burial depth for a vertical wall, a safety factor of at least 1 ft (0.3 m) should be added to the predicted scour depth.

4.3.5 Scour at Protected Bendways

Deep sections at the toe of the outer bank of a bendway are the result of scour. High velocity along the outer bank is caused by secondary currents and greater outer-bank depths, and together with the resultant shear stress, produce scour and cause a difference between the sediment load entering and exiting the outer-bank zone. Since secondary currents transport sediment supplied, in large part, from outer bank erosion toward the inner bank of a bend, hardening of the outer bank by longitudinal bank protection structures may cause the channel cross section to narrow and deepen by preventing the recruitment of eroded outer bank sediments.

Experience is usually the most reliable means of estimating scour depth when designing a bank protection project for a particular stream. Lacking experience on a particular stream, scour depths may be estimated using physically based analytical models or empirical methods. Although scour-depth can be estimated analytically or empirically, empirical methods were generally found to provide better agreement with observed data.

Maynard (1996) provides an empirical method for determining scour depths on a typical bendway bank protection project. Although his studies are restricted to sand bed streams, the Maynard method agrees reasonably well with the limited number of gravel-bed data points obtained by Thorne and Abt (1993). Nonetheless, the techniques presented by Maynard are restricted to meandering channels having naturally developed widths and depths, and cannot be applied to channels that have been confined to widths significantly less than a natural system.

Maynard's method of estimating scour depth is based on a regression analysis of 215 data points. The scour data used in developing his equation were measured at high discharges that were within the channel banks and had return intervals of 1-5 years. Maximum depth as defined in his best-fit equation for scour depth estimation is a function of R_c/W , width to depth ratio, and mean depth as follows:

$$\frac{D_{mxb}}{D_{mnc}} = 1.8 - 0.051 \left(\frac{R_c}{W} \right) + 0.0084 \left(\frac{W}{D_{mnc}} \right) \quad (4.5)$$

where:

- R_c = Centerline radius of the bend, ft (m)
- W = Width of the bend, ft (m)
- D_{mxb} = Maximum water depth in the bend, ft (m)
- D_{mnc} = Average water depth in the crossing upstream of the bend, ft (m)

The terms D_{mxb} and D_{mnc} are defined in Figure 4.3.

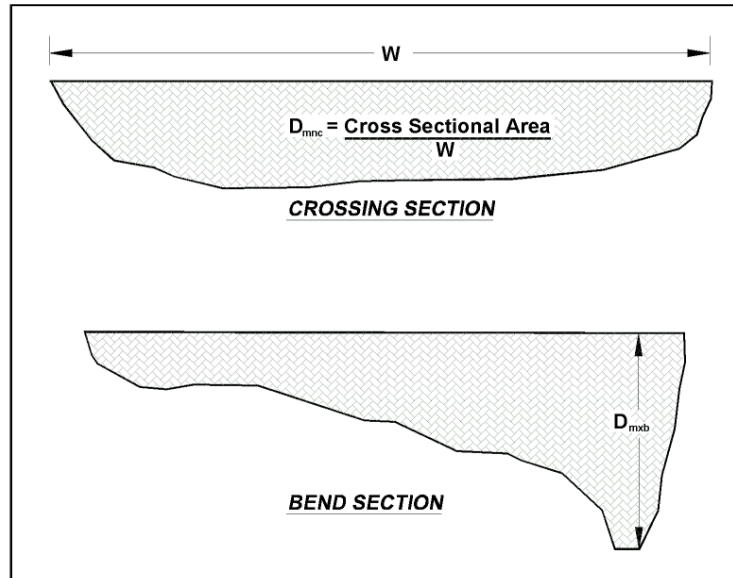

Figure 4.3. Definition sketch of width (W) and mean water depth (D_{mnc}) at the crossing upstream of the bend and maximum water depth in the bend (D_{mxb}).

The applicability of Maynard's equation is limited to streams with R_c/W from 1.5 to 10 and W/D_{mnc} from 20 to 125 because of the lack of data outside these ranges. He recommends that for channels with $R_c/W < 1.5$ or width to depth ratios less than 20, the scour depth for $R_c/W = 1.5$ and $W/D_{mnc} = 20$, respectively, be used.

In addition, Thorne and Abt (1993) suggest these methods are valid until there is significant interaction between the main channel flow and overbank flow. Therefore, Maynard (1996) recommends that application of these empirical methods to overbank flow conditions should be limited to overbank depth less than 20% of main channel depth.

4.3.6 Hydraulic Stress on a Bendway

The ratio of bend radius of curvature to flow width provides insight into the force on the meander bend margin, but this parameter does not include discharge. A quantitative technique which considers a single-event discharge and an estimate of the radial stress on a meander bend margin was developed to evaluate the performance of alternative streambank erosion protection techniques for the U.S. Army Corps of Engineers, Vicksburg District (WET 1990). This technique could also be used by highway engineers to evaluate alternative channel instability countermeasures for a bridge located in a meander bend.

Begin (1981) defines radial stress as the centripetal force divided by the outer bank area. The centripetal force is responsible for deflecting the flow around the bend and is equal to the apparent reactive force of the flow on the bend. Based on this concept of centripetal force, the equation for the radial stress (ϕ_r) of flow on a meander bend is:

$$\phi_r = \frac{F}{A_b} = \frac{\rho QV}{Y(R_c + W/2)} \quad (4.6)$$

where:

- F = Centripetal force, lbs, (N)
- A_b = Area of outer bank, ft² (m²)
- ρ = Fluid density, lbs/ft³ (kg/m³)
- Q = Discharge, ft³/s (m³/s)
- V = Flow velocity, ft/s (m/s)
- Y = Mean flow depth, ft (m)
- R_c = Radius of curvature, ft (m)
- W = Topwidth, ft (m)

Thus, the radial stress is defined as a force per unit area (lbs/ft² or N/m²). Although it is not suggested that the radial stress is directly responsible for meander bend migration or failure of bank protection countermeasures, Begin did show that the radial stress is related to meander migration (Begin 1981). It is assumed that shear stress is related to radial stress because of water surface superelevation and increased near-bank velocity gradients.

Field investigations and computation of radial stress on banklines for channels in the Yazoo River basin in Mississippi clearly showed that rudimentary countermeasures, such as used-tire revetment were generally unsuccessful in bends with even low to moderate radial stress (WET 1990). The study also showed that stone structures including longitudinal stone dikes and stone spurs performed well in reaches of high radial stress. Isolated failures of stone structures did occur at locations with the highest radial stress. The 2-year storm discharge was used in the computations for radial stress at these sites.

As an alternative, the increased shear force on the outside of bends can be calculated by multiplying the bed shear stress τ_0 by a dimensionless bend coefficient K_b . The sharper the bend, the greater the shear stress imposed on the outer bank. The bend coefficient K_b is related to the ratio of the bend radius of curvature R_c divided by the top width of the channel T, as shown in Figure 4.4.

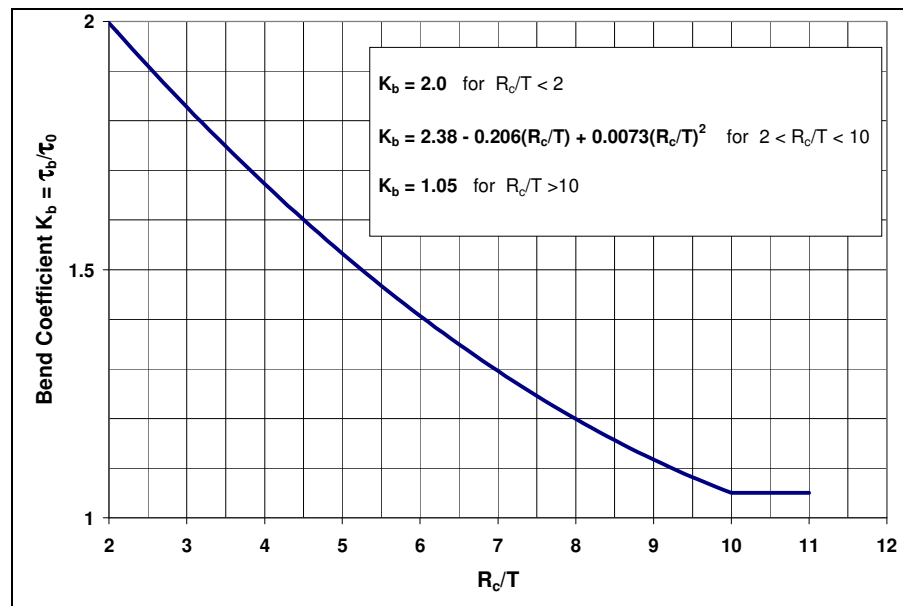

Figure 4.4. Shear stress multiplier K_b for bends (HEC-15, 2005).

CHAPTER 5

RIPRAP DESIGN, FILTERS, FAILURE MODES, AND ALTERNATIVES

5.1 OVERVIEW

Riprap consists of a layer or facing of rock, dumped or hand-placed on channel and structure boundaries to limit the effects of erosion. It is the most common type of countermeasure due to its general availability, ease of installation and relatively low cost. Any successful riprap design must account for several possible modes of failure. These include riprap particle erosion, substrate material erosion and mass failure. Riprap particle erosion is minimized by sizing the riprap to withstand hydraulic and turbulence forces, but is also affected by riprap slope, impact and abrasion, ice, waves and vandalism. Substrate particle erosion occurs when the base material erodes and migrates through the riprap voids causing the riprap to settle. Substrate particle erosion is limited by placing a granular or geotextile filter between the riprap and the base material. Mass failure occurs when large sections of the riprap and/or base material slide or slump due to gravity forces. Mass failure can be caused by excess pore water pressures, bank steepness and loss of basal support through scour or channel migration. Also, a filter fabric that is too fine can clog and cause the buildup of pore water pressures in the underlying soil.

Riprap that is large enough to resist all the hydraulic forces can fail if channel migration or scour undermines the toe support. When the riprap toe is undermined it can shift and remain functional to some degree. Often an extra volume of riprap is included at the toe for this purpose, or the riprap toe is trenched to the depth of potential degradation and contraction scour.

Graded riprap is more stable than uniform riprap because the range of sizes helps the riprap layer to interlock. Care must be taken during construction to ensure that the graded rocks are uniformly distributed. If large rocks roll to the base of the bank and the smaller rocks accumulate at the top, the benefits of using graded riprap will be lost. Also, a relatively uniform riprap surface will be more stable than an extremely uneven riprap surface.

Riprap design requires hydraulic, scour, and stream instability analyses as well as geotechnical investigations of channel and bank stability. Pier riprap can fail if contraction scour or channel bed degradation causes the stones to launch and roll away from the pier, or on rivers with mobile bed forms, by bedform undermining. Abutment riprap can fail if channel migration undermines the toe support of the rock. Channel bank riprap can fail if excess pore pressures or toe scour produce a mechanically unstable bank. These failures could occur even if the riprap size was appropriate for the particular application.

In summary, design of a riprap erosion control system requires knowledge of: river bed, bank, and foundation material; flow conditions including velocity, depth and orientation; riprap characteristics of size, density, durability, and availability; location, orientation and dimensions of piers, abutments, guide banks, and spurs; and the type of interface material between riprap and underlying foundation which may be geotextile fabric or a filter of sand and/or gravel. Adequate "toe down" and termination details are essential to the performance of the riprap system. Thus, riprap should be considered an integrated system where successful performance of a riprap installation depends on the response of each component of the system to hydraulic and environmental stresses throughout its service life.

5.2 RIPRAP DESIGN

5.2.1 Introduction

Most of the guidelines and recommendations of this chapter are derived from NCHRP Report 568, "Riprap Design Criteria, Recommended Specifications, and Quality Control," the final report for NCHRP Project 24-23 (Lagasse et al. 2006). The basic objectives of this study were to develop design guidelines, material specifications and test methods, construction specifications, and construction, inspection and quality control guidelines for riprap for a range of applications, including: revetment on streams and riverbanks, bridge piers and abutments, and bridge scour countermeasures such as guide banks and spurs. NCHRP Project 24-23 was a synthesis study and did not involve any original laboratory experimental work, but some analytical work (specifically 1- and 2-dimensional computer modeling) was necessary to address issues related to input hydraulic variables for design.

Additional guidance for riprap at bridge piers is based on results of the NCHRP Project 24-07(2) provided in NCHRP Report 593, "Countermeasures to Protect Bridge Piers from Scour" (Lagasse et al. 2007). This study involved extensive laboratory testing at Colorado State University of a range of bridge pier scour countermeasures, including: riprap, partially grouted riprap, articulating concrete blocks, gabion mattresses, and grout-filled mattresses. NCHRP Report 593 includes detailed, stand-alone guidelines for the design of these five pier scour countermeasure alternatives.

Sizing the stone is only the first step in the comprehensive design, production, installation, inspection, and maintenance process required for a successful riprap armoring system. Filter requirements, material and testing specifications, construction and installation guidelines, and inspection and quality control procedures are also necessary. This section recommends riprap design approaches for a range of riprap applications. Riprap design (sizing) is covered in more detail in application-specific design guidelines in Volume 2.

Subsequent sections provide an overview of filter design requirements and recommendations for specification, testing, and quality control for revetment riprap installations. In general, these recommendations are applicable to riprap for other applications such as at bridge piers and abutments, and for countermeasures such as spurs and guide banks.

Generalized construction/installation guidance is also summarized in this chapter. Failure modes for revetment and bridge pier riprap are described to underscore the integrated nature of riprap armoring systems and as a basis for developing inspection and maintenance guidance. Finally, an overview of concrete armor units (artificial riprap) that could be used in lieu of rock for selected applications is provided.

5.2.2 Riprap Revetment

Based on a screening of the many riprap revetment design equations found in the literature, seven equations were evaluated with sensitivity analyses using both field and laboratory data during NCHRP Project 24-23 (Lagasse et al. 2006). One, the U.S. Army Corps of Engineers EM 1601, was recommended for streambank revetment design (USACE 1991). Factors considered were the ability of the basic equation to discriminate between stable and failed riprap using field and laboratory data, bank and bend correction factors, and the reasonableness of safety/stability factors. Detailed design guidance using the EM 1601 equation is provided in Volume 2, Design Guideline 4. A standard riprap gradation specification which considers design, production, and installation requirements is recommended in Design Guideline 4, together with a standardized riprap size classification system. Installation guidance for toe down and transitions is also provided for the revetment

application. General riprap specifications, testing, and quality control guidance can be found in Design Guideline 4.

5.2.3 Riprap for Bridge Piers

According to Hoffmans and Verheij (1997) riprap can be sized using either the Isbash or Shields stability criteria if turbulence intensity is incorporated into the velocity component. The effect of turbulence is to increase instantaneous velocities well above the levels for unobstructed flow. This concept is particularly applicable to the pier riprap equations.

The standard Isbash (1936) formula for sizing riprap on a channel bed is:

$$D_{50} = \frac{0.692(KV)^2}{(2g(S_s - 1))} \quad (5.1)$$

where:

$$\begin{aligned} D_{50} &= \text{Riprap size, ft (m)} \\ V &= \text{Velocity, ft/s (m/s)} \\ S_s &= \text{Specific gravity of the riprap (usually 2.65)} \\ K &= 1.0 \end{aligned}$$

To incorporate the effects of turbulence intensity, Hoffmans and Verheij (1997) recommend that the value of K be adjusted above a value of 1.0. In the specific case of circular piers, they recommend using the local velocity upstream of the pier and values of K up to 2.0. This amount of adjustment is equivalent to increasing shear stress by a factor of four.

This approach is similar to the equations presented in Design Guideline 8 and in the riprap sizing formula presented by Parola (1993). The only difference is the recommended values of K in the design guideline are 1.5 for circular piers and 1.7 for square piers. The recommended values of K by Parola ranged from 1.44 to 1.90 depending on pier and footing geometry and approach flow angle of attack.

After a preliminary screening during NCHRP Project 24-23, the HEC-23 (Second Edition) equation, which was derived from work by Parola and Jones, was compared to several other equations using three laboratory data sets. Based on this sensitivity analysis, it was concluded that the HEC-23 and Parola equations provide the best balance between the objective of rarely (if ever) undersizing bridge pier riprap and the desire to not be overly conservative. As these equations are very similar, the HEC-23 (Second Edition) equation was recommended for design practice.

The laboratory results and design recommendations from a concurrent study of countermeasures to protect bridge piers from scour (NCHRP 24-07(2)) were evaluated regarding filter requirements, riprap extent, and other construction/ installation guidelines for pier riprap (Lagasse et al. 2007). Specifically, guidelines for the use of sand-filled geotextile containers as a means of placing a filter for pier riprap derived from European practice were investigated. Construction and installation guidelines and constructability issues were also addressed. The findings and recommendations from NCHRP Projects 24-23 and 24-07(2) are combined in Volume 2, Design Guideline 11 to provide comprehensive design guidance for bridge pier riprap.

5.2.4 Riprap for Bridge Abutments

For NCHRP 24-23, only the abutment riprap sizing approach as developed by FHWA (Pagán-Ortiz 1991, Atayee 1993) and presented in HEC-23 (Second Edition) was considered to be a candidate for further investigation. The approach consists of two equations, one for Froude numbers less than 0.8 and the other for higher Froude numbers. There are no field data available to test these equations and the only available laboratory data set was used to develop the equations. The FHWA equations rely on an estimated velocity, known as the characteristic average velocity, at the abutment toe. Rather than evaluating these equations using the same laboratory data set used to develop them, the method for estimating the velocity at the abutment was investigated in detail. Two-dimensional modeling was performed to evaluate the flow field around an abutment and to verify or improve the Set Back Ratio (SBR) method for estimating velocity for the design equations. Results of the modeling indicated that if the estimated velocity does not exceed the maximum velocity in the channel, the SBR method is well suited for determining velocity at an abutment as a basis for riprap design.

The findings and recommendations from NCHRP Project 24-23 (Lagasse et al. 2006) and NCHRP Project 24-18 (Barkdoll et al. 2007) are presented in Volume 2, Design Guideline 14 for the sizing, filter, and layout of abutment riprap installations. Material and testing specifications, construction and installation guidelines, and inspection and quality control for revetment riprap are suitable for abutment riprap (see Section 5.5 and Design Guideline 4).

5.2.5 Riprap Protection for Countermeasures

In general, design guidelines and specifications for riprap to protect countermeasures are similar to those for bankline revetment or abutments. Consequently, recommendations for revetment riprap can be adapted to the countermeasure application. Guidance for sizing and placing riprap at zones of high stress on countermeasures (e.g., the nose of a guide bank or spur) was developed during NCHRP Project 24-23 (Lagasse et al. 2006). The feasibility of using an abutment-related characteristic average velocity for countermeasure riprap sizing was also evaluated, and a recommendation on an adjustment to the characteristic average velocity approach for guide bank riprap design was developed. Guidance from the U.S. Army Corps of Engineers (EM 1601) can be used for sizing riprap for spurs (USACE 1991). The findings and recommendations from NCHRP Project 24-23 are the basis for design guidance for sizing riprap for spurs in Design Guideline 2 and for guide banks in Design Guideline 15.

NCHRP 24-23 also investigated methods for sizing riprap under overtopping conditions on roadway embankments and the embankment portion of countermeasures. The recommended methodology, based on laboratory testing at Colorado State University, is presented in Design Guideline 5.

5.2.6 Riprap for Special Applications

Environments subject to wave attack frequently require some type of protection to ensure the stability of highway and/or bridge infrastructure. Design Guideline 17 provides information on wave characteristics and procedures for designing rock riprap as protection against wave attack.

Bottomless (or three-sided) culverts are structures that have natural channel materials as the bottom. These structures may be rectangular in shape or may have a more rounded top. They are typically founded on spread footings and can be highly susceptible to scour. Recent laboratory studies by FHWA (Kerenyi 2003, 2007) show that scour is greatest at the upstream corners of the culvert entrance. Based on these studies and other guidance (MDSHA 2005), Design Guideline 18 presents riprap sizing, filter, and layout details to protect against scour at bottomless culverts.

5.2.7 Termination Details

Undermining of the edges of armoring countermeasures like riprap is one of the primary mechanisms of failure (see Section 5.4). The edges of the armoring material (head, toe, and flanks) should be designed so that undermining will not occur. For channel bed armoring, this is accomplished by keying the edges into the subgrade to a depth which extends below the combined expected contraction scour and long-term degradation depth. For side slope protection, this is achieved by trenching the toe of the revetment below the channel bed to a depth which extends below the combined expected contraction scour and long-term degradation depth. When excavation to the contraction scour and degradation depth is impractical, a launching apron can be used to provide enough volume of rock to launch into the channel while maintaining sufficient protection of the exposed portion of the bank. Additional guidelines on edge treatment for riprap countermeasures can be found in Design Guidelines 4, 11, and 14.

5.2.8 Riprap Size, Shape, and Gradation

Riprap design methods typically yield a required size of stone that will result in stable performance under the design loadings. Because stone is produced and delivered in a range of sizes and shapes, the required size of stone is often stated in terms of a minimum allowable representative size. For example, the designer may specify a minimum d_{50} or d_{30} for the rock comprising the riprap, thus indicating the size for which 50% or 30% (by weight) of the particles are smaller. Stone sizes can also be specified in terms of weight (e.g., W_{50} or W_{30}) using an accepted relationship between size and volume, and the known (or assumed) density of the particle.

Shape: The shape of a stone can be generally described by designating three axes of measurement: Major, intermediate, and minor, also known as the "A, B, and C" axes, as shown in Figure 5.1.

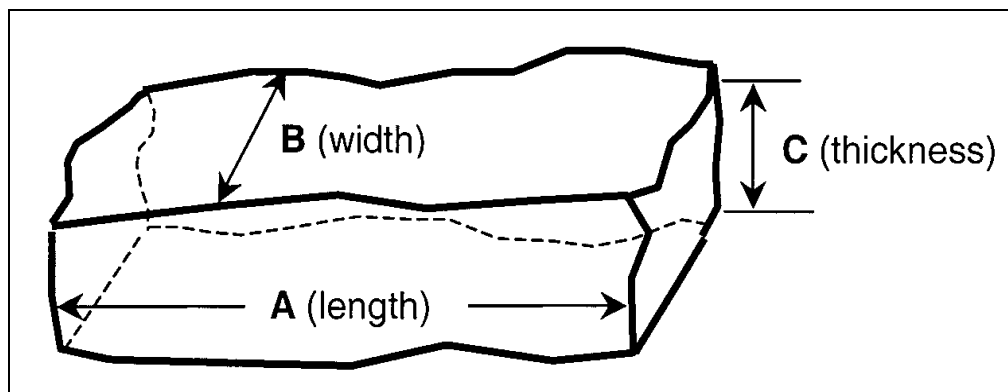

Figure 5.1. Riprap shape described by three axes.

Riprap stones should not be thin and platy, nor should they be long and needle-like. Therefore, specifying a maximum allowable value for the ratio A/C, also known as the shape factor, provides a suitable measure of particle shape, since the B axis is intermediate between the two extremes of length A and thickness C. A maximum allowable value of 3.0 is recommended:

$$\frac{A}{C} \leq 3.0 \quad (5.2)$$

For riprap applications, stones tending toward subangular to angular are preferred, due to the higher degree of interlocking, hence greater stability, compared to rounded particles of the same weight.

Density: A measure of density of natural rock is the specific gravity S_g , which is the ratio of the density of a single (solid) rock particle γ_s to the density of water γ_w :

$$S_g = \frac{\gamma_s}{\gamma_w} \quad (5.3)$$

Typically, a minimum allowable specific gravity of 2.5 is required for riprap applications. Where quarry sources uniformly produce rock with a specific gravity significantly greater than 2.5 (such as dolomite, $S_g = 2.7$ to 2.8), the equivalent stone size can be substantially reduced and still achieve the same particle weight gradation.

Size and weight: Based on field studies, the recommended relationship between size and weight is given by:

$$W = 0.85(\gamma_s d^3) \quad (5.4)$$

where: W = Weight of stone, lb (kg)
 γ_s = Density of stone, lb/ft³ (kg/m³)
 d = Size of intermediate ("B") axis, ft (m)

Table 5.1 provides recommended gradations for ten standard classes of riprap based on the median particle diameter d_{50} as determined by the dimension of the intermediate ("B") axis. These gradations were developed under NCHRP Project 24-23, "Riprap Design Criteria, Recommended Specifications, and Quality Control" (Lagasse et al. 2006). The proposed gradation criteria are based on a nominal or "target" d_{50} and a uniformity ratio d_{85}/d_{15} that results in riprap that is well graded. The target uniformity ratio d_{85}/d_{15} is 2.0 and the allowable range is from 1.5 to 2.5.

To specify riprap using the standard classes shown in Table 5.1, the "next larger size" approach should be adopted. For example, if a riprap sizing calculation results in a required d_{50} of 16.8 inches, Class V riprap should be specified because it has a nominal d_{50} of 18 inches.

Based on Equation 5.4, which assumes the volume of the stone is 85% of a cube, Table 5.2 provides the equivalent particle weights for the same ten classes, using a specific gravity of 2.65 for the particle density.

Nominal Riprap Class by Median Particle Diameter		d ₁₅		d ₅₀		d ₈₅		d ₁₀₀
Class	Size	Min	Max	Min	Max	Min	Max	Max
I	6 in	3.7	5.2	5.7	6.9	7.8	9.2	12.0
II	9 in	5.5	7.8	8.5	10.5	11.5	14.0	18.0
III	12 in	7.3	10.5	11.5	14.0	15.5	18.5	24.0
IV	15 in	9.2	13.0	14.5	17.5	19.5	23.0	30.0
V	18 in	11.0	15.5	17.0	20.5	23.5	27.5	36.0
VI	21 in	13.0	18.5	20.0	24.0	27.5	32.5	42.0
VII	24 in	14.5	21.0	23.0	27.5	31.0	37.0	48.0
VIII	30 in	18.5	26.0	28.5	34.5	39.0	46.0	60.0
IX	36 in	22.0	31.5	34.0	41.5	47.0	55.5	72.0
X	42 in	25.5	36.5	40.0	48.5	54.5	64.5	84.0

Note: Particle size d corresponds to the intermediate ("B") axis of the particle.

Nominal Riprap Class by Median Particle Weight		W ₁₅		W ₅₀		W ₈₅		W ₁₀₀
Class	Weight	Min	Max	Min	Max	Min	Max	Max
I	20 lb	4	12	15	27	39	64	140
II	60 lb	13	39	51	90	130	220	470
III	150 lb	32	93	120	210	310	510	1100
IV	300 lb	62	180	240	420	600	1000	2200
V	1/4 ton	110	310	410	720	1050	1750	3800
VI	3/8 ton	170	500	650	1150	1650	2800	6000
VII	1/2 ton	260	740	950	1700	2500	4100	9000
VIII	1 ton	500	1450	1900	3300	4800	8000	17600
IX	2 ton	860	2500	3300	5800	8300	13900	30400
X	3 ton	1350	4000	5200	9200	13200	22000	48200

Note: Weight limits for each class are estimated from particle size by: $W = 0.85(\gamma_s d^3)$ where d corresponds to the intermediate ("B") axis of the particle, and particle specific gravity is taken as 2.65.

5.3 FILTER REQUIREMENTS

5.3.1 Overview

The importance of the filter component of a countermeasure for stream instability or bridge scour installation should not be underestimated. Filters are essential to the successful long-term performance of countermeasures, especially armoring countermeasures. There are two basic types of filters: granular filters and geotextile filters. Some situations call for a composite filter consisting of both a granular layer and a geotextile. The specific characteristics of the base soil determine the design considerations for the filter layer. ***In general, where dune-type bedforms may be present during flood events, it is strongly recommended that only a geotextile filter be considered for use with countermeasures.***

The filter must retain the coarser particles of the subgrade while remaining permeable enough to allow infiltration and exfiltration to occur freely. It is not necessary to retain all the particle sizes in the subgrade; in fact, it is beneficial to allow the smaller particles to pass through the filter, leaving a coarser substrate behind. The filter prevents excessive migration of the base soil particles through the voids in the armor layer, permits relief of hydrostatic pressure beneath the armor, and distributes the weight of the armor to provide more uniform settlement.

Guidance for the design of both granular and geotextile filters is provided in National Cooperative Highway Research Program (NCHRP) Report 568, "Riprap Design Criteria, Recommended Specifications, and Quality Control" (Lagasse et al. 2006), and is found in Volume 2 as Design Guide 16. When using a granular filter, the layer should have a minimum thickness of 4 times the d_{50} of the filter stone or 6 inches, whichever is greater. When placement must occur under water, the layer thickness should be increased by 50%. In flowing water, the placement of both granular and geotextile filters becomes challenging. Under these conditions, special materials and placement techniques have been developed to ensure that a quality filter installation is achieved, as discussed in the next section.

5.3.2 Placing Geotextiles Under Water

Placing geotextiles under water is problematic for a number of reasons. Most geotextiles that are used as filters beneath riprap are made of polyethylene or polypropylene. These materials have specific gravities ranging from 0.90 to 0.96, meaning that they will float unless weighted down or otherwise anchored to the subgrade prior to placement of the armor layer (Koerner 1998). In addition, unless the work area is isolated from river currents by a cofferdam, flow velocities greater than about 1.0 ft/s (0.3 m/s) create large forces on the geotextile. These forces cause the geotextile to act like a sail, often resulting in wavelike undulations of the fabric (a condition that contractors refer to as "galloping") that are extremely difficult to control. In mild currents, geotextiles (precut to length) have been placed using a roller assembly, with sandbags to hold the fabric temporarily.

To overcome these problems, engineers in Germany have developed a product known as SandMat™. This blanket-like product consists of two nonwoven needle-punched geotextiles (or a woven and a nonwoven) with sand in between. The layers are stitch-bonded or sewn together to form a heavy, filtering geocomposite. The composite blanket exhibits an overall specific gravity ranging from approximately 1.5 to 2.0, so it sinks readily.

According to Heibaum (2002), this composite geotextile has sufficient stability to be handled even when loaded by currents up to approximately 3.3 ft/s (1 m/s). At the geotextile – base soil interface, a nonwoven fabric should be used because of the higher angle of friction compared to woven geotextiles. Figure 5.2 shows a close-up photo of the SandMat™ material. Figure 5.3 shows the SandMat™ blanket being rolled out using conventional geotextile placement equipment.

In deep water or in currents greater than 3.3 ft/s (1 m/s), German practice calls for the use of sand-filled geotextile containers. For specific project conditions, geotextile containers can be chosen that combine the resistance against hydraulic loads with the filtration capacity demanded by the application. Geotextile containers have proven to give sufficient stability against erosive forces in many applications, including wave-attack environments. The size of the geotextile container must be chosen such that the expected hydraulic load will not transport the container during placement (Heibaum 2002). Once placed, the geotextile containers are overlaid with the final armoring material (e.g., riprap or partially grouted riprap) as shown in Figure 5.4.



Figure 5.2. Close-up photo of SandMat™ geocomposite blanket.
(photo from NCHRP Project 24-07(2), courtesy Colcrete – Von Essen Inc.)



Figure 5.3. SandMat™ geocomposite blanket being unrolled.
(photo from NCHRP Project 24-07(2), courtesy Colcrete – Von Essen Inc.)

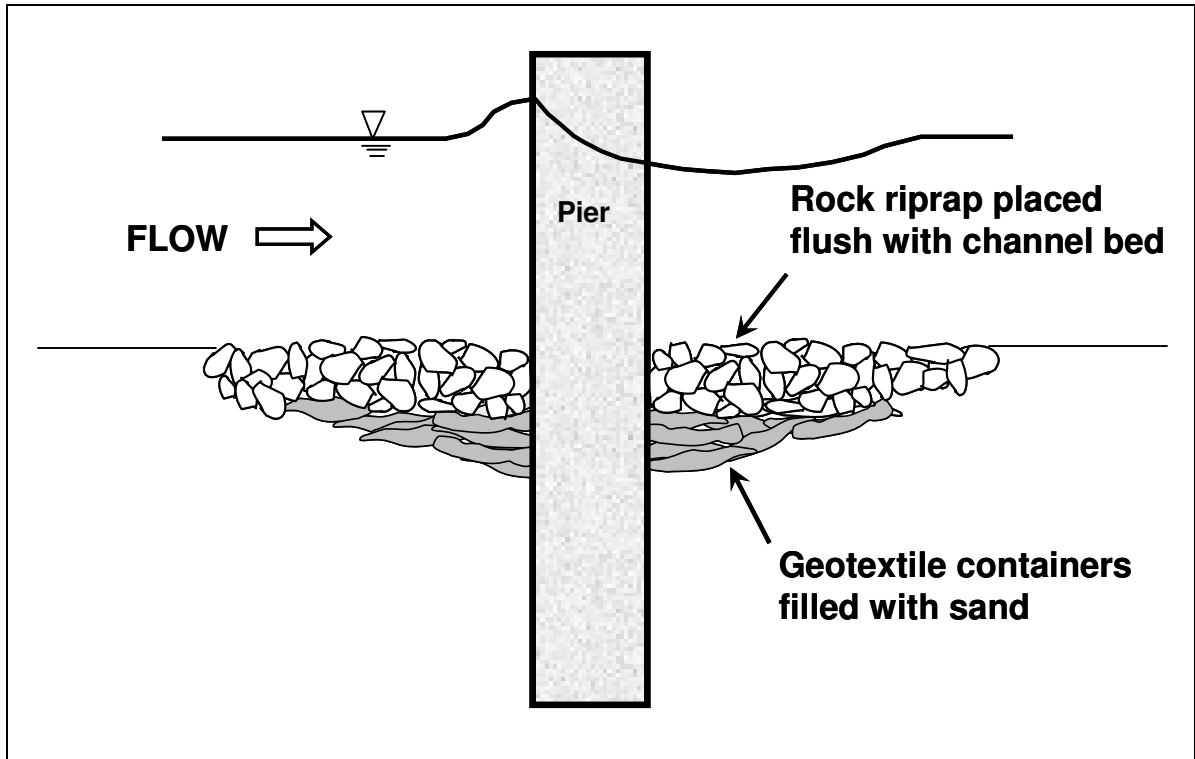

Figure 5.4. Sand-filled geotextile containers.

Figure 5.5 shows a geotextile container being filled with sand. Figure 5.6 shows the sand-filled geotextile container being handled with an articulated-arm clam grapple. The filled geotextile container in the photograph is a nominal 1-metric-tonne (1,000 kg or 2,200 lb) unit. The preferred geotextile for these applications is always a non-woven needle punched fabric, with a minimum mass per unit area of 500 grams per square meter. Smaller geotextile containers can be fabricated and handled by one or two people for smaller-sized applications.

As a practical minimum, a 200-lb (91 kg) geotextile container covering a surface area of about 6 to 8 square ft (0.56 to 0.74 m²) can be fashioned from nonwoven needle punched geotextile having a minimum mass per unit area of 200 grams per square meter, filled at the job site and field-stitched with a hand-held machine. Figure 5.7 illustrates the smaller geotextile containers being installed at a prototype-scale test installation for NCHRP Project 24-07(2) (Lagasse et al. 2007) in a pier scour countermeasure application (see also Design Guidelines 11 and 12, Volume 2).

5.4 RIPRAP FAILURE MODES

As discussed in Section 5.1, riprap can be considered an integrated system for which successful performance of a riprap installation depends on the response of each component of the system to hydraulic and environmental stresses throughout its service life. This section provides an overview of failure modes for revetment and bridge pier riprap to underscore the integrated nature of riprap armoring systems and support development of inspection guidance.



Figure 5.5. Filling 1.0 metric tonne geotextile container with sand.
(photo from NCHRP Project 24-07(2), courtesy Colcrete – Von Essen Inc.)



Figure 5.6. Handling a 1.0 metric tonne sand-filled geotextile container.
(photo from NCHRP Project 24-07(2), courtesy Colcrete – Von Essen Inc.)



Figure 5.7. Two hundred lb (91 kg) sand-filled geotextile containers, NCHRP Project 24-07(2).

5.4.1 Riprap Revetment Failure Modes

In a preliminary evaluation of various riprap design techniques, Blodgett and McConaughy (1986) concluded that a major shortcoming of all present design techniques is the assumption that failures of riprap revetment are due only to particle erosion. Procedures for the design of riprap protection need to consider all the various causes of failures which include: (1) particle erosion; (2) translational slide; (3) modified slump; and (4) slump.

Particle erosion is the most commonly considered erosion mechanism (Figure 5.8). Particle erosion occurs when individual particles are dislodged by the hydraulic forces generated by the flowing water. Particle erosion can be initiated by abrasion, impingement of flowing water, eddy action/reverse flow, local flow acceleration, freeze/thaw action, ice, or toe erosion. Probable causes of particle erosion include: (1) stone size not large enough; (2) individual stones removed by impact or abrasion; (3) side slope of the bank so steep that the angle of repose of the riprap material is easily exceeded; and (4) gradation of riprap too uniform. Figure 5.9 provides a photograph of a riprap failure due to particle displacement.

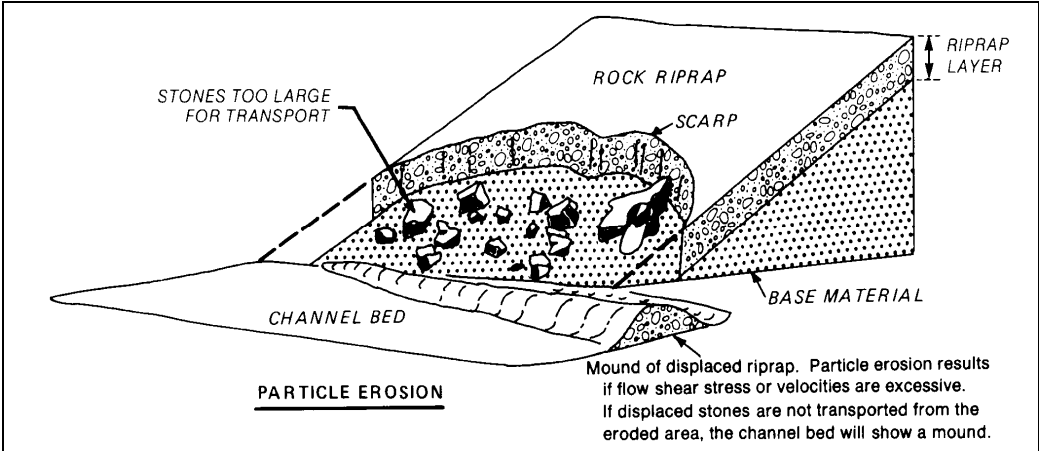

Figure 5.8. Riprap failure by particle erosion (Blodgett and McConaughy 1986).

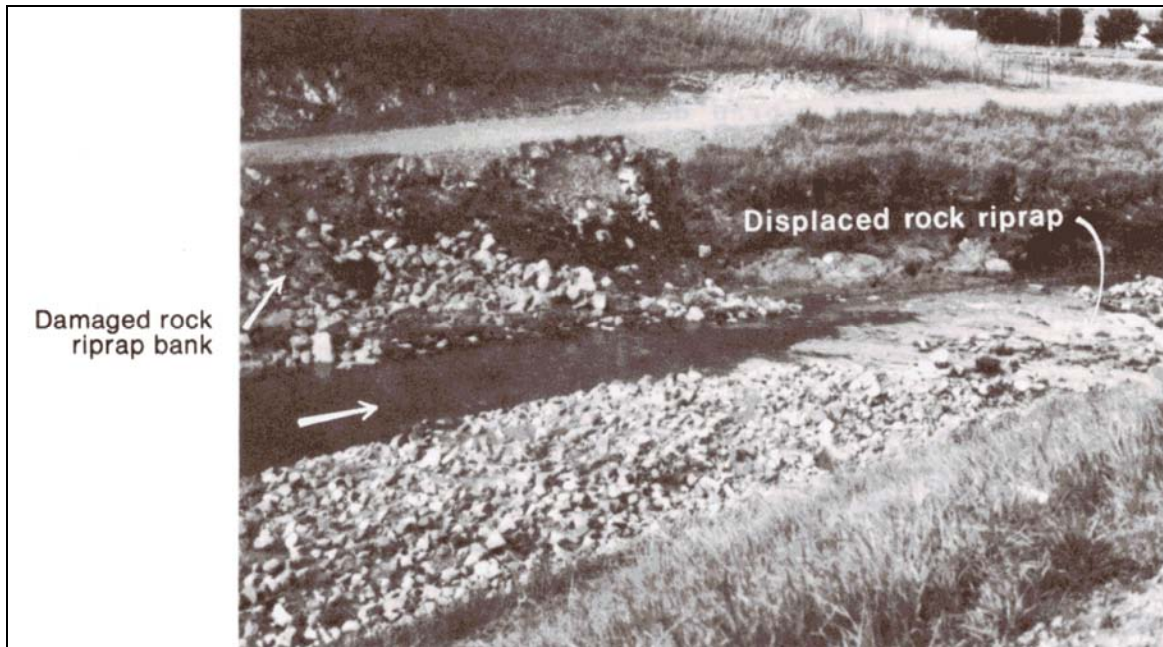

Figure 5.9. Damaged riprap on left bank of Pinole Creek at Pinole, CA, following flood of January 4, 1982. Note deposition of displaced riprap from upstream locations in channel bed (photographed March 1982) (Blodgett & McConaughy 1986).

A translational slide is a failure of riprap caused by the downslope movement of a mass of stones, with the fault line on a horizontal plane (Figure 5.10). The initial phases of a translational slide are indicated by cracks in the upper part of the riprap bank that extend parallel to the channel. This type of riprap failure is usually initiated when the channel bed scours and undermines the toe of the riprap blanket. This could be caused by particle erosion of the toe material, or some other mechanism which causes displacement of toe material. Any other mechanism which would cause the shear resistance along the interface between the riprap blanket and base material to be reduced to less than the gravitational force could also cause a translational slide. Probable causes of translational slides are as follows: (1) bank side slope too steep; (2) presence of excess hydrostatic (pore) pressure; and (3) loss of foundation support at the toe of the riprap blanket caused by erosion of the lower part of the riprap blanket. Figure 5.11 provides a photograph of a riprap failure due to a translational sliding-type failure.

Modified slump failure of riprap (Figure 5.12) is the mass movement of material along an internal slip surface within the riprap blanket. The base soil underlying the riprap does not fail. This type of failure is similar in many respects to the translational slide, but the geometry of the damaged riprap is similar in shape to initial stages of failure caused by particle erosion. Probable causes of modified slump are: (1) bank side slope is so steep that the riprap is resting very near the angle of repose, and any imbalance or movement of individual stones creates a situation of instability for other stones in the blanket; and (2) material critical to the support of upslope riprap is dislodged by settlement of the submerged riprap, impact, abrasion, particle erosion, or some other cause. Figure 5.13 provides a photograph of a riprap failure due to a modified slump-type failure.

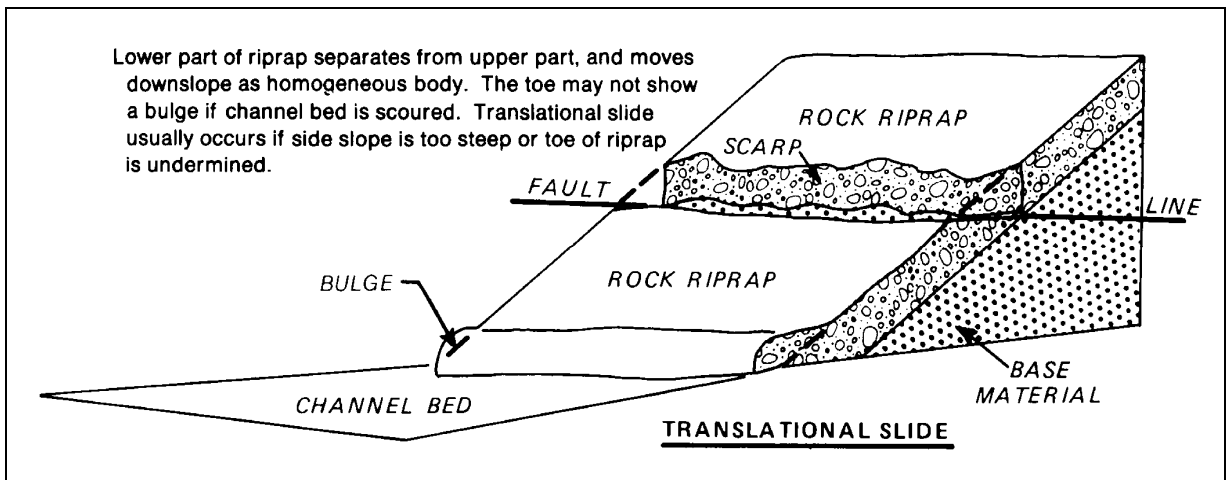

Figure 5.10 . Riprap failure by translational slide (Blodgett and McConaughy 1986).



Figure 5.11. Riprap on Cosumnes River at Site 2 near Sloughouse, CA, looking downstream, showing translational slide failure (photographed May 31, 1983) (Blodgett & McConaughy 1986).

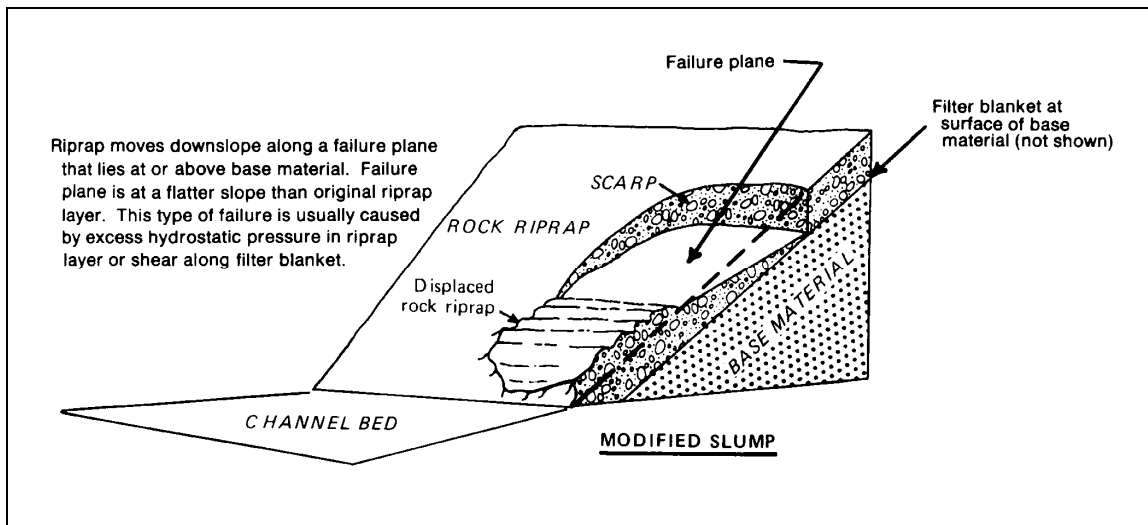

Figure 5.12. Riprap failure by modified slump (Blodgett and McConaughy 1986).



Figure 5.13. Riprap on Consumnes River at Site 3 near Sloughouse, CA, looking downstream, showing modified slump failure (photographed May 31, 1983) (Blodgett & McConaughy 1986).

Slump failure is a rotational-gravitational movement of material along a surface of rupture that has a concave upward curve (Figure 5.14). The cause of slump failures is related to shear failure of the underlying base soil that supports the riprap. The primary feature of a slump failure is the localized displacement of base material along a slip surface, which is usually caused by excess pore pressure that reduces friction along a fault line in the base material. Probable causes of slump failures are: (1) non-homogeneous base material with layers of impermeable material that act as a fault line when subject to excess pore pressure; (2) side slopes too steep and gravitational forces exceeding the inertia forces of the riprap and base material along a friction plane; and (3) too much overburden at the top of the slope (may be caused in part by the riprap). Figure 5.15 provides a photograph of a riprap failure due to a slump-type failure.

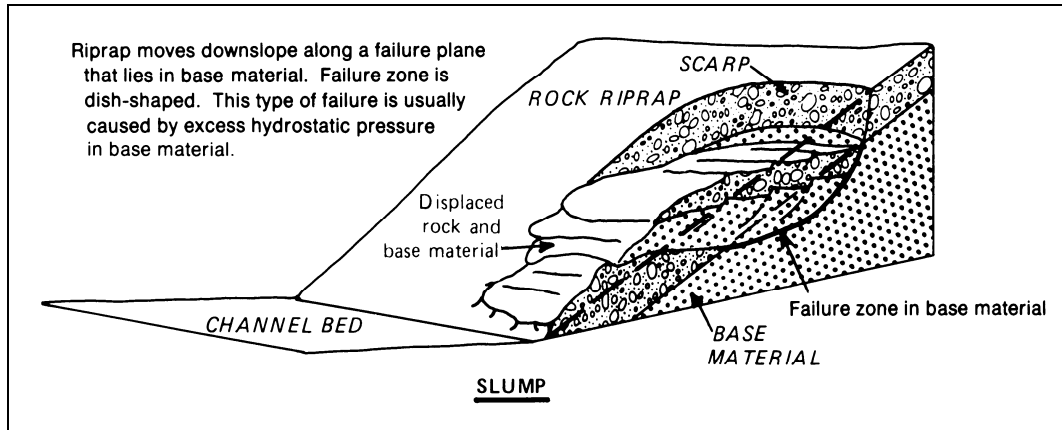

Figure 5.14. Riprap failure due to slump (Blodgett and McConaughy 1986).



Figure 5.15. Riprap on left bank Cosumnes River at Site 1 near Sloughouse, CA, showing slump failure (photographed May 31, 1983) (Blodgett & McConaughy 1986).

Summary: Blodgett and McConaughy (1986) conclude that certain hydraulic factors are associated with each of the four types of riprap failure (particle erosion, translational slide, modified slump, and true slump). While the specific mechanism causing failure of the riprap is difficult to determine, and a number of factors, acting either individually or combined, may be involved, they identify the reasons for riprap failures as:

1. Particle size was too small because:

- Shear stress was underestimated
- Velocity was underestimated
- Inadequate allowance was made for channel curvature
- Design channel capacity was too low
- Design discharge was too low
- Inadequate assessment was made of abrasive forces
- Inadequate allowance was made for effect of obstructions

2. Channel changes caused:
 - Impinging flow
 - Flow to be directed at ends of protected reach
 - Decreased channel capacity or increased depth
 - Scour
3. Riprap material had improper gradation
4. Material was placed improperly
5. Side slopes were too steep
6. No filter blanket was installed or blanket was inadequate or damaged
7. Excess pore pressure caused failure of base material or toe of riprap
8. Differential settlement occurred during submergence or periods of excessive precipitation

5.4.2 Pier Riprap Failure Modes

A study of the causes of riprap failure at model bridge piers (Chiew 1995) under clear-water conditions with gradually increasing approach flow velocities defined three modes of pier riprap failure:

1. Riprap shear failure – whereby the riprap stones cannot withstand the downflow and horseshoe vortex associated with the pier scour mechanism.
2. Winnowing failure – whereby the underlying finer bed material is removed through voids or interstices in the riprap layer.
3. Edge failure – whereby instability at the edge of the coarse riprap layer and the bed sediment initiates a scour hole beginning at the perimeter and working inward that ultimately destabilizes the entire layer.

Since live-bed conditions are more likely to occur during flood flows, additional experiments were conducted to evaluate the stability of pier riprap under live-bed conditions with migrating bed forms (Lim and Chiew 1996). These experiments and subsequent research Melville et al. (1997), Lauchlan (1999), and Lauchlan and Melville (2001) indicates that bed-form undermining is the controlling failure mechanism at bridge piers on rivers with mobile bed forms, especially sand bed rivers. The most important factors affecting the stability of the riprap layer under live-bed conditions were the turbulent flow field around the pier and the fluctuations of the bed level caused by bed forms (e.g., dunes) as they migrate past the pier. The three failure modes defined for clear-water conditions also exist under live-bed conditions and they may act independently or jointly with migrating bed forms to destabilize the riprap layer.

Once sediment transport starts and bed forms associated with the lower flow regime (i.e., ripples and dunes) begin to form, the movement of sediments at the edge of the riprap layer remove the support of the edge stones. When the trough of a bed feature migrated past the riprap layer, stones would slide into the trough, causing the riprap layer to thin. Depending on the thickness of the remaining riprap layer following stone sliding and layer thinning, winnowing may occur as a result of exposure of the underlying fine sediments to the flow. Winnowing can cause the entire remaining riprap layer to subside into the bed. With thicker riprap layers winnowing is not a factor and there is no subsidence.

Under steady flow conditions, the inherent flexibility of a riprap layer can provide a self-healing process (Chiew 1995). As scour occurs and sediment is removed from around the riprap layer through the three modes of erosion described above, the riprap layer, if it has sufficient thickness, can adjust itself to the mobile channel bed and remain relatively intact while providing continued scour protection for the pier. However, when flow velocity is steadily increased, riprap shear, winnowing, and edge erosion combine to cause either a total disintegration or embedment failure of the riprap layer in the absence of an underlying filter (either geotextile or granular).

Total disintegration, which is characterized by a complete breakup of the riprap layer whereby the stones are washed away by the flow, occurs when the self-healing ability of the riprap layer is exceeded by the erosive power created by higher flow velocity. Total disintegration occurs when the riprap stone size to sediment size ratio is small. Embedment failure occurs when: (1) the riprap stones are large compared to the bed sediment and local erosion around the individual stones causes them to embed into the channel bed (i.e., differential mobility); and (2) the riprap stones lose their stability as bed forms pass and drop into the troughs of the migrating bed forms (i.e., bed feature destabilization).

5.4.3 Pier Riprap Failure Modes – Schoharie Creek Case Study

The failure of the I-90 bridge over Schoharie Creek near Albany, New York on April 5, 1987, which cost 10 lives, was investigated by the National Transportation Safety Board (NTSB) (Richardson and Davis 2001). The peak flow was 64,900 cfs (1,838 m³/s) with a 70- to 100-year return period. The foundations of the four bridge piers were large spread footings 82 ft (25 m) long, 18 ft (5.5 m) wide, and 5 ft (1.5 m) deep without piles. The footings were set 5 ft (1.5 m) into the stream bed in very dense ice contact stratified glacial drift, which was considered nonerrodible by the designers (Figure 5.16). However, flume studies of samples of the stratified drift showed that some material would be eroded at a velocity of 4 ft/s (1.5 m/s), and at a velocity of 8 ft/s (2.4 m/s) the erosion rates were high.

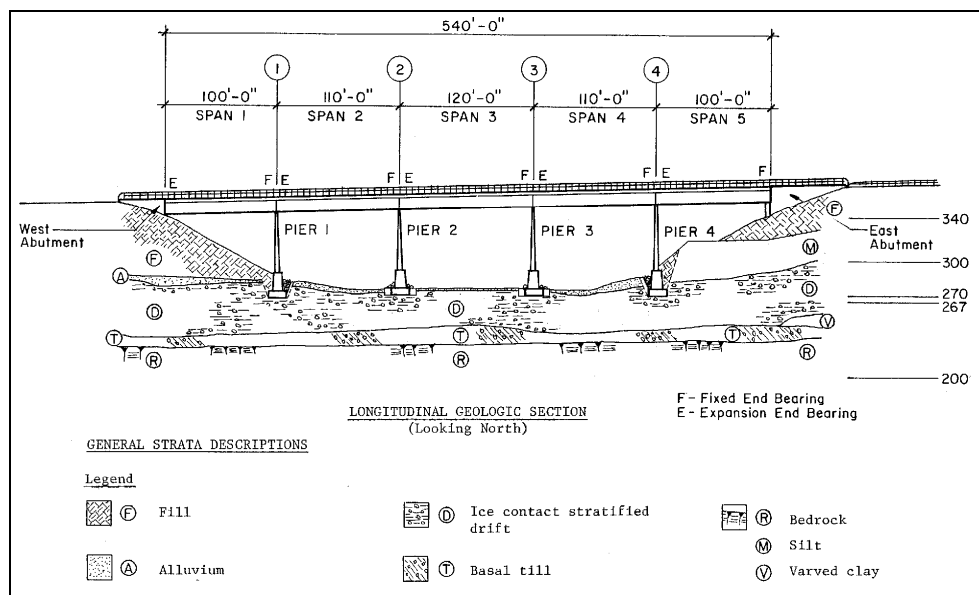

Figure 5.16. South elevation - Schoharie Creek Bridge showing key structural features and a schematic geological section (Richardson et al. 1987).

A 1 to 50 scale, 3-dimensional, model study indicated a prototype flow velocity of 10.8 ft/s (3.3 m/s) at the pier that failed. Also, the 1 to 50 scale and a 1 to 15 scale, 2-dimensional model study gave 15 ft (4.6 m) of maximum scour depth. The scour depth of the prototype pier (pier 3) at failure was 14 ft (4.3 m) (Figure 5.17).



Figure 5.17. Pier scour holes at Schoharie Creek Bridge in 1987. Pier 2 in the foreground with pier 3 in the background.

Design plans called for the footings to be protected with riprap. Over time (1953 to 1987), much of the riprap was removed by high flows. NTSB gave as the probable cause "... the failure of the New York State Thruway authority to maintain adequate riprap around the bridge piers, which led to severe erosion in the soil beneath the spread footings. Contributing to the severity of the accident was the lack of structural redundancy in the bridge" (NTSB 1988).

The NYSTA inspected the bridge annually or biennially with the last inspection on April 1, 1986. A 1979 inspection by a consultant hired by NYSDOT indicated that most of the riprap around the piers was missing (Figures 5.18 and 5.19); however, the 1986 inspection failed to detect any problems with the condition of the riprap at the piers. Based on the NTSB findings, the conclusions from this failure are that inspectors and their supervisors must recognize that riprap does not necessarily make a bridge safe from scour, and inspectors must be trained to recognize when riprap is missing and the significance of this condition.

Summary: Examples of the most common modes of riprap failure at piers provide guidance for post-flood and post-construction performance evaluation. Inspectors need to be aware of, and understand, the causes of riprap inadequacies that they see in the field. While the specific mechanism causing failure of the riprap is difficult to determine, and a number of factors, acting either individually or combined, may be involved, the reasons for riprap failures at bridge piers can be summarized as follows:

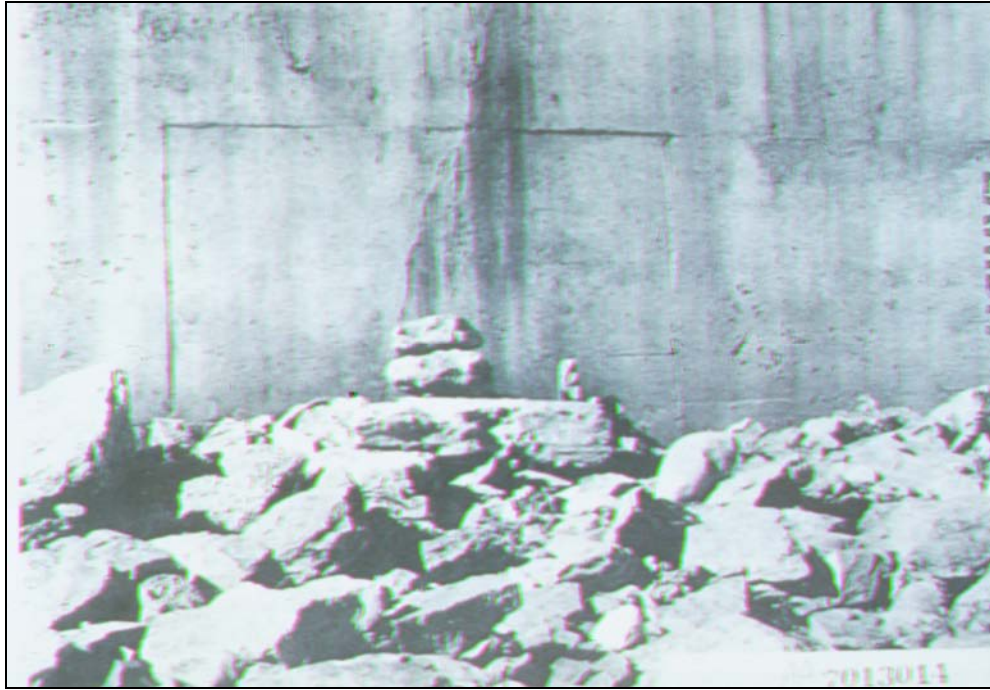

Figure 5.18. Photograph of riprap at pier 2, October 1956.



Figure 5.19. Photograph of riprap at pier 2, August 1977 (flow is from right to left).

1. Particle size was too small because:
 - Shear stress was underestimated
 - Velocity was underestimated
 - Inadequate allowance was made for channel curvature
 - Design channel capacity was too low
 - Design discharge was too low
 - Inadequate assessment was made of abrasive forces
 - Inadequate allowance was made for effect of obstructions (such as debris)
2. Channel changes caused:
 - Increased angle of attack (skew)
 - Decreased channel capacity or increased depth
 - Scour
3. Riprap material had improper gradation
4. Material was placed improperly
5. No filter blanket was installed or blanket was inadequate or damaged

5.5 RIPRAP INSPECTION GUIDANCE

5.5.1 General

Inspection of riprap placement typically consists of visual inspection of the installation procedures and the finished surface. Inspection must ensure that a dense, rough surface of well-keyed graded rock of the specified quality and sizes is obtained, that the layers are placed such that voids are minimized, and that the layers are the specified thickness.

If the riprap installation is part of channel stability works in the vicinity of a bridge, it is typically inspected during the biennial bridge inspection program. However, more frequent inspection might be required by the Plan of Action for a particular bridge or group of bridges. In some cases, inspection may be required after every flood that exceeds a specified magnitude. Underwater inspection of a riprap system should only be performed by divers specifically trained and certified for such work.

The following general guidance for inspecting riprap is presented in the National Highway Institute (NHI) training course 135047, "Stream Stability and Scour at Highway Bridges for Bridge Inspectors:"

1. Riprap should be **angular and interlocking** (Old bowling balls would not make good riprap). Flat sections of broken concrete paving do not make good riprap.
2. Riprap should have a **granular or synthetic geotextile filter** between the riprap and the subgrade material.
3. Riprap should be **well graded** (a wide range of rock sizes). The maximum rock size should be no greater than about twice the median (d_{50}) size.
4. For bridge piers, riprap should generally extend up to the bed elevation so that the top of the riprap is visible to the inspector during and after floods.

5. When inspecting riprap, the following are strong indicators of problems:
- Has riprap been **displaced** downstream?
 - Has angular riprap blanket **slumped** down slope?
 - Has angular riprap material been **replaced** over time by smoother river run material?
 - Has riprap material physically **deteriorated, disintegrated**, or been **abraded** over time?
 - Are there **holes** in the riprap blanket where the filter has been exposed or breached?

5.5.2 Guidance for Recording Riprap Condition

To guide the inspection of a riprap installation, a recording system is presented in **Appendix D**. This guidance establishes numerical ratings from 0 (worst) to 9 (best). Recommended action items based on the numerical rating are also provided (Lagasse et al. 2006).

5.5.3 Performance Evaluation

The evaluation of any revetment system's performance should be based on its design parameters as compared to actual field experience, longevity, and inspection / maintenance history. To properly assess the performance of revetment riprap, the history of hydraulic loading on the installation, in terms of flood magnitudes and frequencies, must also be considered and compared to the design loading. Guidance for the performance evaluation of riprap armoring systems is provided in NCHRP Report 593 (Lagasse et al. 2007).

Changes in channel morphology may have occurred over time subsequent to the installation of the riprap. Present-day channel cross-section geometry and planform should be compared to those at the time of installation. Both lateral and vertical instability of the channel can significantly alter hydraulic conditions at the site. Approach flows may exhibit an increasingly severe angle of attack (impinging flow) over time, increasing the hydraulic loading on the riprap.

Deficiencies noted during the inspection should be corrected as soon as possible. As with any armor system, progressive failure from successive flows must be avoided by providing timely maintenance intervention.

5.6 GROUTED AND PARTIALLY GROUTED RIPRAP

Grouted riprap is rock slope paving with voids filled with concrete grout forming a monolithic armor. Because fully grouted riprap is a rigid structure, it will not conform to bank settlement or toe undermining as loose riprap does. Therefore, fully grouted riprap is susceptible to mass failure, especially if pore water is not allowed to drain properly. Although the revetment is rigid, it is not particularly strong and even a small loss of toe or bank support can result in the failure of large portions of the structure.

The primary advantage of fully grouted riprap is that the grout anchors the rock and eliminates particle erosion of the revetment. Therefore, smaller rock can be used for the revetment, and the total thickness of the revetment can be reduced as compared with traditional riprap revetment. Another advantage is that a relatively smooth surface can be achieved and, therefore, the hydraulic efficiency of the waterway is improved. Filters are not required for fully grouted riprap but drainage of pore water must be provided. **A significant disadvantage of fully grouted riprap is that a complete layer of grout converts a**

flexible revetment to a rigid cover, subject to the potential problems of any rigid slope paving, including undercutting at the toe, out flanking, and the possibility of sudden catastrophic failure.

An alternative to fully grouted riprap is partially grouted riprap. In general, the objective is to increase the stability of the riprap without sacrificing its flexibility. Partial grouting of riprap may be well suited for areas where rock of sufficient size is not available to construct a loose riprap revetment.

The River and Channel Revetments design manual published by H.R. Wallingford in the United Kingdom (Escarameia 1998) provides design guidance for grouting "hand pitched stone" with both bituminous and cement grout. For grouting riprap in the United Kingdom, bitumen is the material most commonly used. Although various degrees of grouting are possible, effective solutions are usually produced when the bituminous mortar envelopes the loose stone and leaves relatively large voids between rock particles. The degrees of bituminous grouting available are:

- Surface grouting (which does not penetrate the whole thickness of the revetment and corresponds to about one-third of the voids filled)
- Various forms of pattern grouting (where only some of the surface area of the revetment is filled, between 50 to 80% of voids)
- Full grouting (an impermeable type of revetment)

Partial grouting of riprap with a cement slurry is presented as one of several standard design approaches for permeable revetments in a discussion of considerations regarding the experience and design of German inland waterways (Heibaum 2000). Partially grouted riprap consists of appropriately sized rocks that are grouted together with grout filling only 1/3 to 1/2 of the total void space (Figure 5.20). In contrast to fully grouted riprap, partial grouting increases the overall stability of the riprap installation unit without sacrificing flexibility or permeability. It also allows for the use of smaller rock compared to standard riprap, resulting in decreased layer thickness. Design, specification, and construction guidance for partially grouted riprap is provided in Design Guideline 12, Volume 2.

The holes in the grout allow for drainage of pore water so a filter is required. The grout forms conglomerates of riprap so the stability against particle erosion is greatly improved and, as with fully grouted riprap, a smaller thickness of stone can be used (Figure 5.21). Although not as flexible as riprap, partially grouted riprap will conform somewhat to bank settlement and toe exposure.

An important consideration for partially grouted riprap is that construction methods must be closely monitored to insure that the appropriate voids and surface openings are provided. Contractors in Germany have developed techniques and equipment to achieve the desired grout coverage and the right penetration. Various European countries have developed special grout mixes and construction methods for underwater installation of partially grouted riprap (see Design Guideline 12).



Figure 5.20. Close-up view of partially grouted riprap.



Figure 5.21. "Conglomerate" of partially grouted riprap, Federal Waterway Engineering and Research Institute, Karlsruhe, Germany (Heibaum 2000).

5.7 CONCRETE ARMOR UNITS

Concrete armor units, also known as artificial riprap, consist of individual pre-cast concrete units with complex shapes that are placed individually or in interconnected groups. These units were originally developed for shore protection to resist wave action during extreme storms. All are designed to give a maximum amount of interlocking using a minimum amount of material. These devices are used where natural riprap is unavailable or is more costly to obtain than fabrication of the artificial riprap units. Parker et al. (1998) provide a review of studies conducted on the use of concrete armor units as pier scour countermeasures.

Various designs for size and shape of concrete armor units are available and include such commercial names as Tetrapods, Tetrahedrons, Toskanes, Dolos, Tribars, Accropodes, Core-Loc™, and A-Jacks® (Figure 5.22). Because concrete armor units are similar to riprap, they can be susceptible to the same failure mechanisms as riprap. The use of a filter layer or geotextile in conjunction with these types of devices is often required, especially in coastal applications, and a geotextile or filter may be critical to the stability of these devices when used as pier scour protection (see Design Guideline 19 for design procedures for Toskanes and A-Jacks®).

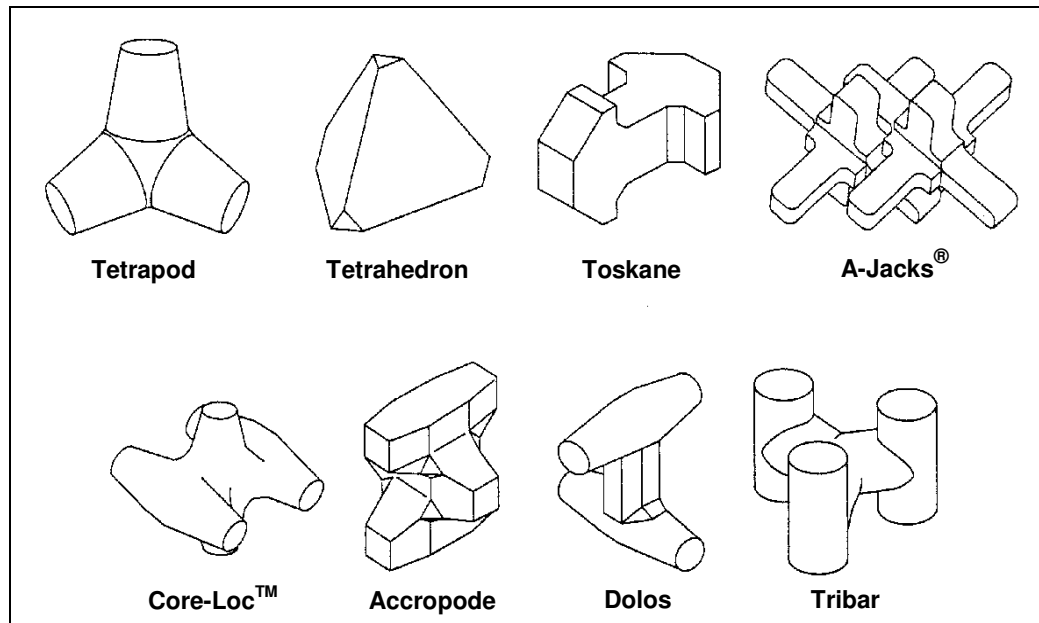

Figure 5.22. Concrete armor units.

The primary advantage of armor units is that they usually have greater stability compared to riprap particles of equivalent weight. This is due to the interlocking characteristics of their complex shapes. The increased stability allows their placement on steeper slopes or the use of lighter weight units for equivalent flow conditions as compared to riprap. This is significant when riprap of a required size is not available.

The design of armor units in open channels is based on the selection of appropriate sizes and placement patterns to be stable in flowing water. The armor units should be able to withstand the flow velocities without being displaced. Hydraulic testing is used to measure the hydraulic conditions at which the armor units begin to move or "fail," and dimensional

analysis allows extrapolation of the results to other hydraulic conditions. Although a standard approach to the stability analysis has not been established, design criteria have been developed for various armor units using the following dimensionless parameters:

- Isbash stability number (Parola 1993; Ruff and Fotherby 1995; Bertoldi et al. 1996)
- Shields parameter (Bertoldi et al. 1996)
- Froude number (Brown and Clyde 1989)

The Isbash stability number and Shields parameter are indicative of the interlocking characteristics of the armor units. Froude number scaling is based on similitude of stabilizing and destabilizing forces. Quantification of these parameters requires hydraulic testing and, typically, regression analysis of the data. Prior research and hydraulic testing have provided guidance on the selection of the Isbash stability number and Shields parameter for riprap and river sediment particles, but stability values are not available for all concrete armor units. Therefore, manufacturers of concrete armor units have a responsibility to test their products and to develop design criteria based on the results of these tests. Since armor units vary in shape and performance from one proprietary system to the next, each system will have unique performance properties.

Installation guidelines for concrete armor units in streambank revetment and channel armor applications should consider subgrade preparation, edge treatment (toe down and flank) details, armor layer thickness, and filter requirements. Subgrade preparation and edge treatment for armor units is similar to that required for riprap. Considerations for armor layer thickness and filter requirements are product specific and should be provided by the armor unit manufacturer.

Concrete armor units have shown potential for mitigating the effects of local scour in the laboratory; however, only limited data are available on their performance in the field. Research efforts are currently being conducted to test the performance of concrete armor units as pier scour countermeasures in the field.

Design methods which incorporate velocity (a variable which can be directly measured) are commonly used to select local scour countermeasures. Normally an approach velocity is used in the design equation (generally a modified Isbash equation) with a correction factor for flow acceleration around the pier or abutment (see Section 5.2.3).

Although tetrahedrons are currently used for bank protection (Fotherby 1995), they have garnered very little interest with regard to pier scour protection in the United States. This may be primarily related to their lack of appendages and interlock (i.e., their simple compact shape is similar to riprap and spheres). Dolos also have not been seriously considered for use as pier scour protection because they have no inherent interlocking property to resist movement under steady state turbulent flow (Brebner 1978). Extensive testing and research has been conducted on the Core-Loc[®] system, which was developed by the U.S. Army Engineer Waterways Experiment Station, but the testing was limited exclusively to coastal applications. Accropode and tribar systems are used almost exclusively in coastal applications as well.

In contrast, tetrapods have been extensively studied and evaluated for use as pier scour protection (Fotherby 1992, 1993; Bertoldi et al. 1996; Jones et al. 1995; Bertoldi and Kilgore 1993). Fotherby (1992, 1993) and Stein et al. (1998) suggest that tetrapods offer little advantage compared to riprap in terms of stability. Layering and density had no appreciable

effect on the stability of the tetrapods, although the stability increased with the size of the tetrapod pad. Work by Bertoldi et al. (1996) and Stein et al. (1998) indicates that riprap and tetrapods behaved comparably when both stability number and spherical stability number were compared, and also suggest that fixing the perimeter and varying the number of tetrapod layers may have an effect on stability.

A specific design procedure for Toskanes has been developed for application at bridge piers and abutments where the Toskanes are installed as individual, interlocking units. The design procedures for Toskanes are based on extensive research conducted at Colorado State University (Ruff and Fotherby 1995; Fotherby 1995; Burns et al. 1996; Fotherby and Ruff 1998, 1999). Based on hydraulic model studies conducted at Colorado State University for the Pennsylvania Department of Transportation, Burns et al. (1996) presented procedures for the design of Toskane pads, provided criteria for sizing Toskanes, and suggested techniques for installation of Toskanes (Figure 5.23). No other concrete armor unit has been as extensively tested and evaluated for use as a pier scour countermeasure (see Design Guideline 19).

Another approach to using concrete armor units for pier scour protection involves the installation of banded modules of the A-Jacks[®] armor unit (Ayres Associates 1999; Thornton et al. 1999). Laboratory testing results and installation guidelines developed at Colorado State University by Ayres Associates (1999) for the A-Jacks[®] system illustrate the "modular" design approach in contrast with the "discrete particle" approach for Toskanes (Figure 5.24).

The discrete particle design approach illustrated by the Toskane design guidelines concentrates on the size, shape, and weight of individual armor units, whether randomly placed or in stacked or interlocked configurations. In contrast, the basic construction element of A-Jacks[®] for pier scour applications is a "module" comprised of a minimum of 14 individual A-Jacks[®] banded together in a densely-interlocked cluster, described as a 5x4x5 module. The banded module thus forms the individual design element as illustrated in Figure 5.24 (see Design Guideline 19).

As with any countermeasure, the armor units must withstand several potential failure modes. Providing resistance against the hydraulic stresses may not be sufficient for structure success. If the armor units are used to counter pier scour, they must also remain stable for channel degradation, contraction scour, and the passage of bed forms (dunes). If armor units are used as bank revetment, then the stability of the bank must be analyzed for potential toe scour, pore water pressures and saturated soil strengths.

It should also be noted that concrete armor units, depending on their size, may be very susceptible to vandalism. In addition, there may be maintenance and degradation issues associated with any cables used to tie groups of concrete armor units together.



Figure 5.23. Laboratory study of Toskanes for pier scour protection.



Figure 5.24. Installation of A-Jacks® modular units installed by Kentucky DOT for pier scour protection.

CHAPTER 6

BIOTECHNICAL ENGINEERING

6.1 OVERVIEW

Vegetation is the most natural method for protecting streambanks because it is relatively easy to establish and maintain and is visually attractive. However, vegetation alone should not be seriously considered as a countermeasure against severe bank erosion where a highway facility is at risk. At such locations, vegetation can best serve to supplement other countermeasures.

Vegetation can effectively protect a bank below the design water line in two ways. First, the root system helps to hold the soil together and increases overall bank stability by forming a binding network. Second, the exposed stalks, stems, branches and foliage provide resistance to flow, causing the flow to lose energy by deforming the plants rather than by removing soil particles. Above the water line, vegetation prevents surface erosion by absorbing the impact of falling raindrops and reducing the velocity of overbank flow and rainfall runoff.

Vegetation is generally divided into two broad categories: (1) grasses, and (2) woody plants (trees and shrubs). A major factor affecting species selection is the length of time required for the plant to become established on the slope. Grasses are less costly to plant on an eroding bank and require a shorter period of time to become established. Woody plants offer greater protection against erosion because of more extensive root systems; however, under some conditions the weight of the plant will offset the advantage of the root system. On high banks, tree root systems may not penetrate to the toe of the bank. If the toe becomes eroded, the weight of the tree and its root mass may cause a bank failure.

There are several synonymous terms that describe the field of vegetative streambank stabilization and countermeasures. Terms for the use of 'soft' revetments (consisting solely of living plant materials or plant products) include bioengineering, soil bioengineering, ground bioengineering, and ecological bioengineering. Terms describing the techniques that combine the use of vegetation with structural (hard) elements include biotechnical engineering, biotechnical slope protection, bioengineered slope stabilization, and biotechnical revetment. The terms soil bioengineering and biotechnical engineering are most commonly used to describe stream bank erosion countermeasures and bank stabilization methods that incorporate vegetation. Where riprap constitutes the "hard" component of biotechnical slope protection, the term vegetated riprap is also used.

6.2 CURRENT PRACTICE

Due to a lack of technical training and experience, there is a reluctance on the part of many engineers to resort to soil bioengineering and biotechnical engineering techniques and stability methods. In addition, bank stabilization systems using vegetation have not been standardized for general application under particular flow conditions. There is a lack of knowledge about the properties of the materials being used in relation to force and stress generated by flowing water and there may be difficulties in obtaining consistent performance from countermeasures that rely on living materials. Nonetheless, stabilization of eroding stream banks using vegetative countermeasures has proven effective in many documented cases in Europe and the United States.

Most hydraulic engineers in Europe would not recommend the reliance on bioengineering countermeasures as the only countermeasure technique when there is a risk of damage to property or a structure, or where there is potential for loss of life if the countermeasure fails (TRB 1999). Soil bioengineering is not suitable where flow velocities exceed the strength of the bank material or where pore water pressure causes failures in the lower bank. In contrast, biotechnical engineering is particularly suitable where some sort of engineered structural solution is required because the risk associated with using just vegetation is considered too high. However, the use of soil bioengineering and biotechnical engineering with respect to scour and stream instability at highway bridges is a relatively new field. Research has been conducted, but these techniques have generally not been tested specifically as a countermeasure to protect bridges in the river environment.

Design of biotechnically engineered countermeasures to minimize rates of stream bank erosion requires accounting for hydrologic, hydraulic, geomorphic, geotechnical, vegetative, and construction factors. Although most of the literature dealing with biotechnical engineering on rivers is associated with stream bank stabilization relative to channel restoration and rehabilitation projects, it is also generally applicable to bank stabilization associated with bridge crossings. Bentrup and Hoag (1998), Johnson and Stypula (1998), U.S. Army Engineer Waterways Experiment Station (1998), and the Federal Interagency Stream Restoration Working Group (1998) provide detailed guidelines, techniques, and methods of biotechnical engineering for bank stabilization in the United States. Guidelines, methodology, and design of biotechnically engineered streambank stabilization in Europe and the United Kingdom are discussed in Schiechl and Stern (1997), Morgan et al. (1997), and Escarameia (1998).

6.3 GENERAL CONCEPTS

The following discussion is drawn primarily from concepts presented in NCHRP Report 544 entitled, "*Environmentally Sensitive Channel- and Bank-Protection Measures*," (McCullah and Gray 2005) where biotechnical techniques are referred to as "vegetated riprap."

Continuous and resistive bank protection measures, such as riprap and longitudinal rock toes are primarily used to armor outer bends or areas with impinging flows. These continuous and concentrated high velocity areas will generally result in reduced aquatic habitat. It has been widely documented that resistive techniques in general and riprap in particular, provide minimal aquatic habitat benefits (Shields et al. 1995). Recently the concerns over the poor aquatic-habitat value of riprap, both locally and cumulatively, have made the use of riprap alone controversial (Washington Department of Fish and Wildlife 2003).

Since streambank protection designs that consist of riprap, concrete, or other inert structures alone may be unacceptable for lack of environmental and aesthetic benefits, there is increasing interest in designs that combine vegetation with inert materials into living systems that can reduce erosion while providing environmental and aesthetic benefits (Sotir and Nunnally 1995).

The negative environmental consequences of riprap can be reduced by minimizing the height of the rock revetment up the bank and/or including biotechnical methods, such as vegetated riprap with brush layering and pole planting, vegetated riprap with soil, grass and ground cover, vegetated riprap with willow (*Salix* spp.) bundles, and vegetated riprap with bent poles.

Combining riprap with deep vegetative planting (e.g., brush layering and pole planting) is also appropriate for banks with geotechnical problems, because additional tensile strength is often contributed by roots, stems, and branches. In contrast, trees and riparian vegetation planted only on top of the bank can sometimes have a negative impact (Simon and Collison 2002).

Correctly designed and installed, vegetated riprap offers an opportunity for the designer to attain the immediate and long-term protection afforded by riprap with the habitat benefits inherent with the establishment of a healthy riparian buffer. The riprap will resist the hydraulic forces, while roots and branches increase geotechnical stability, prevent soil loss (or piping) from behind the structures, and increase pullout resistance.

Above ground components of the plants will create habitat for both aquatic and terrestrial wildlife, provide shade (reducing thermal pollution), and improve aesthetic and recreational opportunities. The roots, stems, and shoots will help anchor the rocks and resist 'plucking' and gouging by ice and debris.

6.4 ADVANTAGES AND LIMITATIONS OF BIOTECHNICAL ENGINEERING

Specific ways vegetation can protect stream banks as part of a biotechnical engineering approach include:

- The root system binds soil particles together and increases the overall stability and shear strength of the bank.
- The exposed vegetation increases surface roughness and reduces local flow velocities close to the bank, which reduces the transport capacity and shear stress near the bank, thereby inducing sediment deposition.
- Vegetation dissipates the kinetic energy of falling raindrops, and depletes soil water by uptake and transpiration.
- Vegetation reduces surface runoff through increased retention of water on the surface and increases groundwater recharge.
- Vegetation deflects high-velocity flow away from the bank and acts as a buffer against the abrasive effect of transported material.
- Vegetation improves the conditions for fisheries and wildlife and helps improve water quality.

In addition, biotechnical engineering is often less expensive than most methods that are entirely structural and it is often less expensive to construct and maintain when considered over the long-term.

The critical threats to the successful performance of biotechnical engineering projects are improper site assessment, design or installation, and lack of monitoring and maintenance (especially following floods and during droughts).

Some of the specific limitations to the use of vegetation for streambank erosion control include:

- Lack of design criteria and knowledge about properties of vegetative materials
- Lack of long-term quantitative monitoring and performance assessment
- Difficulty in obtaining consistent performance from countermeasures relying on live materials
- Possible failure to grow and susceptibility to drought conditions
- Depredation by wildlife or livestock
- Significant maintenance may be required

More importantly, the type of plants that can survive at various submersions during the normal cycle of low, medium, and high stream flows is critical to the design, implementation, and success of biotechnical engineering techniques. In addition, the combination of riprap and vegetation may be inappropriate if flow capacity is an issue, since bank vegetation can reduce flow capacity, especially when in full leaf along a narrow channel.

6.5 DESIGN CONSIDERATIONS FOR BIOTECHNICAL COUNTERMEASURES

In an unstable watershed, careful study should be made of the causes of instability before biotechnical countermeasures are contemplated (see HEC-20) (Lagasse et al. 2001a). Since bank erosion is tied to channel stability, a stable channel bed must be achieved before the banks are addressed. Scour and erosion of the bank toe produce the dominant failure modes (see HEC-20), consequently, most biotechnical engineering projects documented in the literature contain some form of structural (hard) toe stabilization, such as rock riprap (Figure 6.1), rock gabions, cribs, cable anchored logs, or logs with root wads anchored by boulders (Figure 6.2). Note the use of a fascine bundle in Figure 6.1 as part of the rock toe protection. Toe protection should be keyed into the channel bed sufficiently deep to withstand significant scour, and the biotechnically engineered revetment should be keyed into the bank at both the upstream and downstream ends (called refusals) to prevent flanking. Deflectors such as fences, dikes, and pilings may also be utilized to deflect flow away from the bankline.

Other factors that need to be considered when selecting a design option include climate and hydrology, soils, cross-sectional dimensions (is there sufficient room for the countermeasure), flow depth, flow velocity (both magnitude and direction), and slope of the bankline being protected. Most methods of biotechnical engineering will require some amount of bank regrading. Because structure design is based on flood velocities and depths, one or more design flows will need to be analyzed. Of particular interest is the bankfull or overtopping event, since this event generates the greatest velocities and tractive forces. Local (at or near the project site) flow velocities should be used for the design, especially along the outside of bends. The erosion protection should extend far enough downstream, particularly on the outer banks of bends. The highest velocities generally occur at the downstream arc of a bend and on the outer bank of the exit reach immediately downstream. As noted, the countermeasures should be tied into the bank at both ends to prevent flanking.

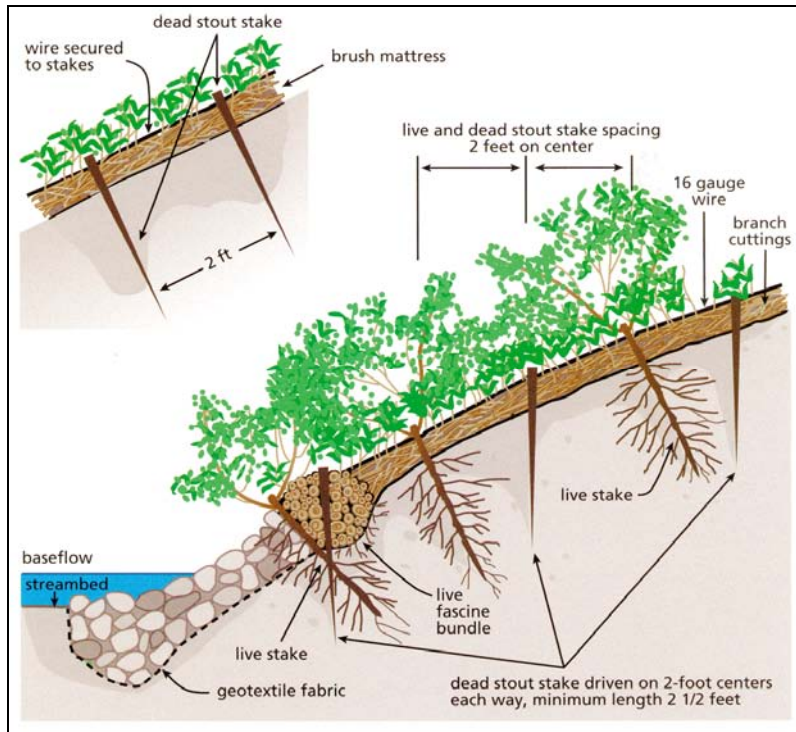

Figure 6.1. Details of brush mattress technique with stone toe protection (FISRWG 1998).

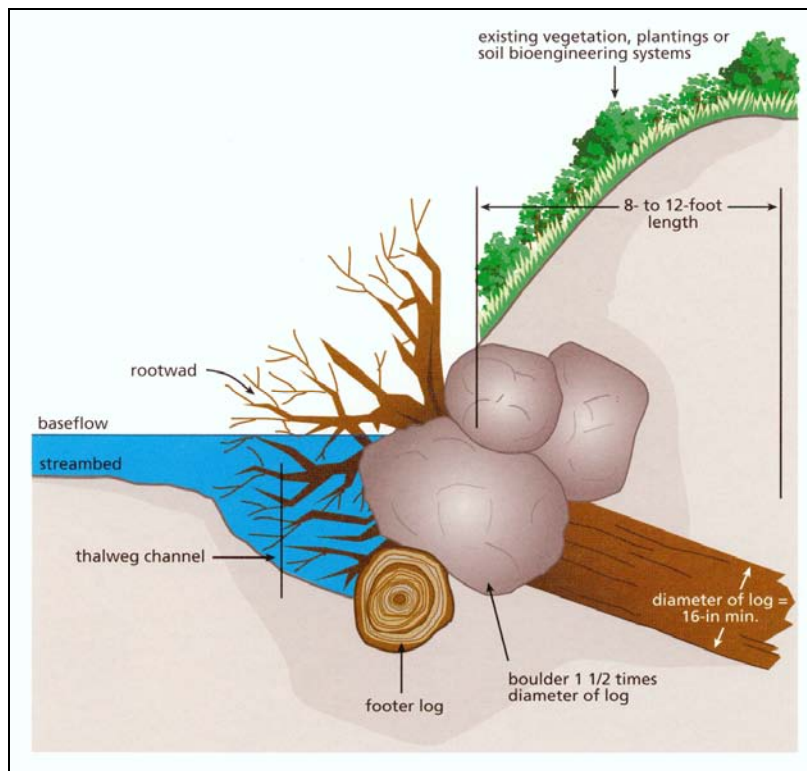

Figure 6.2. Details of root wad and boulder revetment technique (FISRWG 1998).

6.6 COMMONLY USED VEGETATIVE METHODS

Five methods for constructing vegetated riprap have proven effectiveness. Typical design concept sketches of the five methods are provided as Figures 6.3 through 6.7. These sketches are reproduced from NCHRP Report 544 (McCullah and Gray 2005). It should be noted that the key hydraulic design variable "design high water" is not defined in these sketches, and "average high water" (AHW) and "average low water" are only qualitatively described.

1. Vegetated riprap with willow bundles (Figure 6.3): Vegetated riprap with willow bundles is the simplest to install, but it has a few drawbacks. This technique typically requires very long 10-23 ft (3-7 m) poles and branches, as the cuttings should reach from 6 inches (15 cm) below the low water table to 1 ft (30 cm) above the top of the rocks. In addition, only those cuttings that are in contact with the soil will take root, and therefore, the geotechnical benefits of the roots from those cuttings on the top of the bundle may not be realized.
2. Vegetated riprap with bent poles (Figure 6.4): Vegetated riprap with bent poles is slightly more complex to install, and is the only method that can be installed with filter fabric. Additionally, a variety of different lengths of willow cuttings can be used because they will protrude from the rock at different elevations.
3. Vegetated riprap with brush layering and pole planting (Figure 6.5): Vegetated riprap with brush layering and pole planting is the most complex type of riprap to install, but also provides the most immediate habitat benefits. The installation of this technique is separated into two methods; one method describes installation when building a bank back up, while the other is for a well-established bank. If immediate aquatic habitat benefits are desired, this technique should be used. However, vegetated riprap with brush layering and pole planting may not provide the greatest amount of root reinforcement, as the stem-contact with soil does not extend up the entire slope. Combination of this technique with pole- or bundle-planted riprap will perform well, as the latter techniques typically have higher rooting success.
4. Vegetated riprap with soil cover, grass and ground cover (Figure 6.6): This technique is also known as "buried riprap," and consists of infilling and covering a standard rock riprap installation with soil and subsequently establishing grass vegetation. Some stripping of the soil and grass may be expected during severe events.
5. Joint or Live Stake Planted Riprap (Figure 6.7): Joint or live stake planted riprap is revegetated riprap, as opposed to the other techniques, which are true vegetated riprap methods. This technique should be used only when attempting to get vegetative growth on previously installed riprap.

6.7. ENVIRONMENTAL CONSIDERATIONS AND BENEFITS

There are many environmental benefits offered by vegetated riprap, most of which are derived from the planting of willows or other woody species in the installation. Willow provides canopy cover to the stream, which gives fish and other aquatic fauna cool places to hide. The vegetation also supplies the river with carbon-based debris, which is integral to many aquatic food webs, and birds that catch fish or aquatic insects will be attracted by the increased perching space next to the stream (Gray and Sotir 1996).

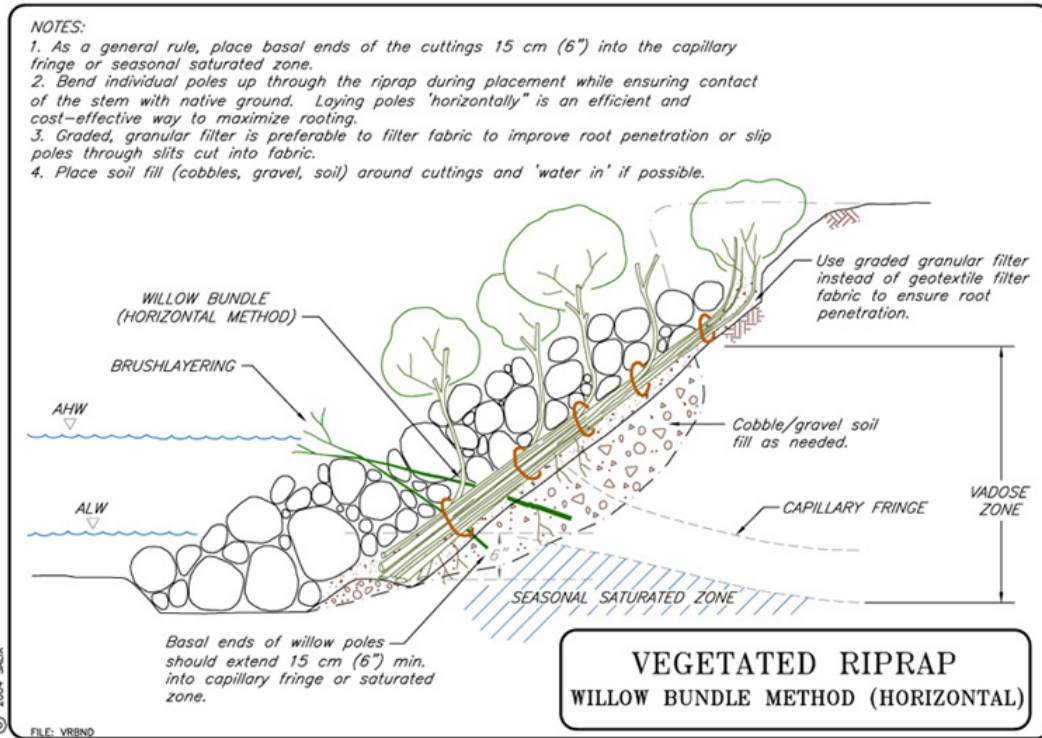

Figure 6.3. Vegetated riprap - willow bundle method (McCullah and Gray 2005).

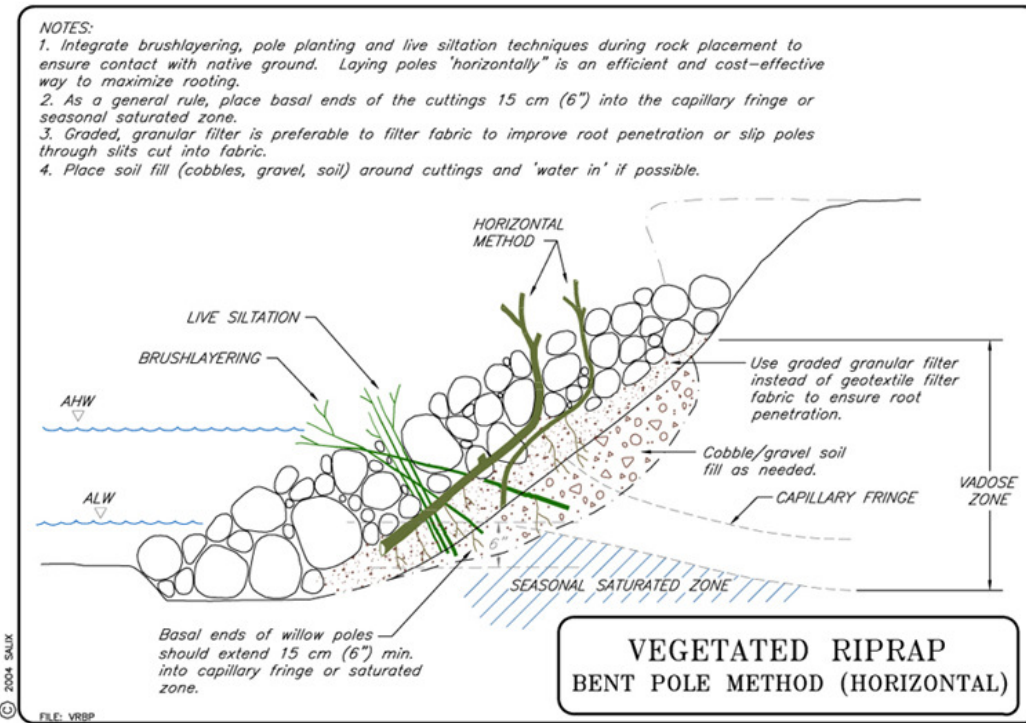

Figure 6.4. Vegetated riprap - bent pole method (McCullah and Gray 2005).

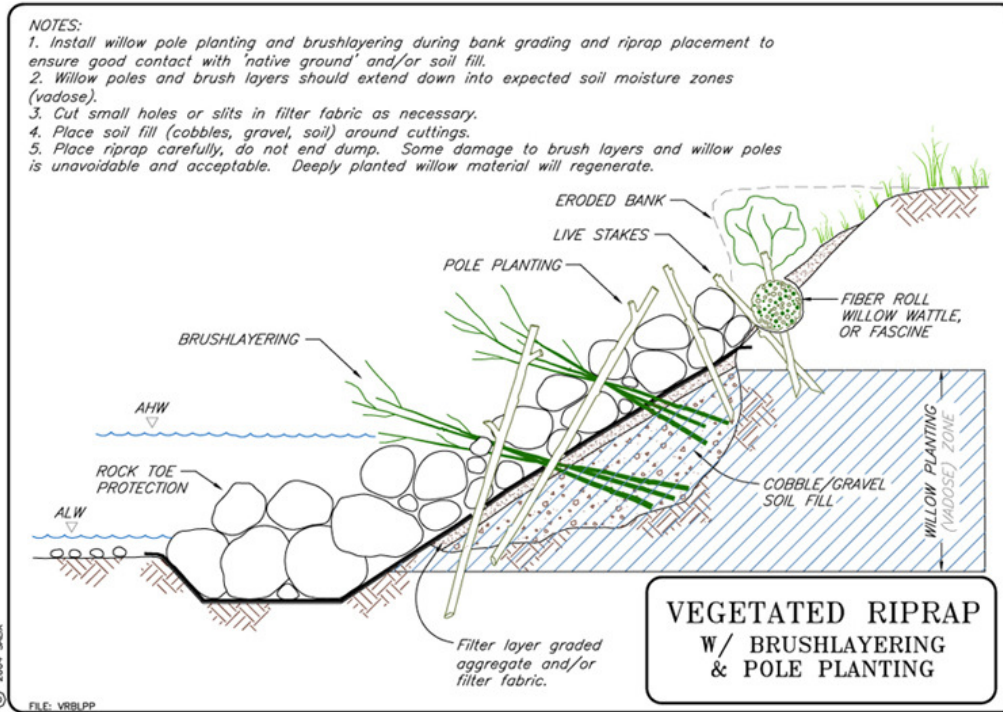

Figure 6.5. Vegetated riprap - brush layering with pole planting (McCullah and Gray 2005).

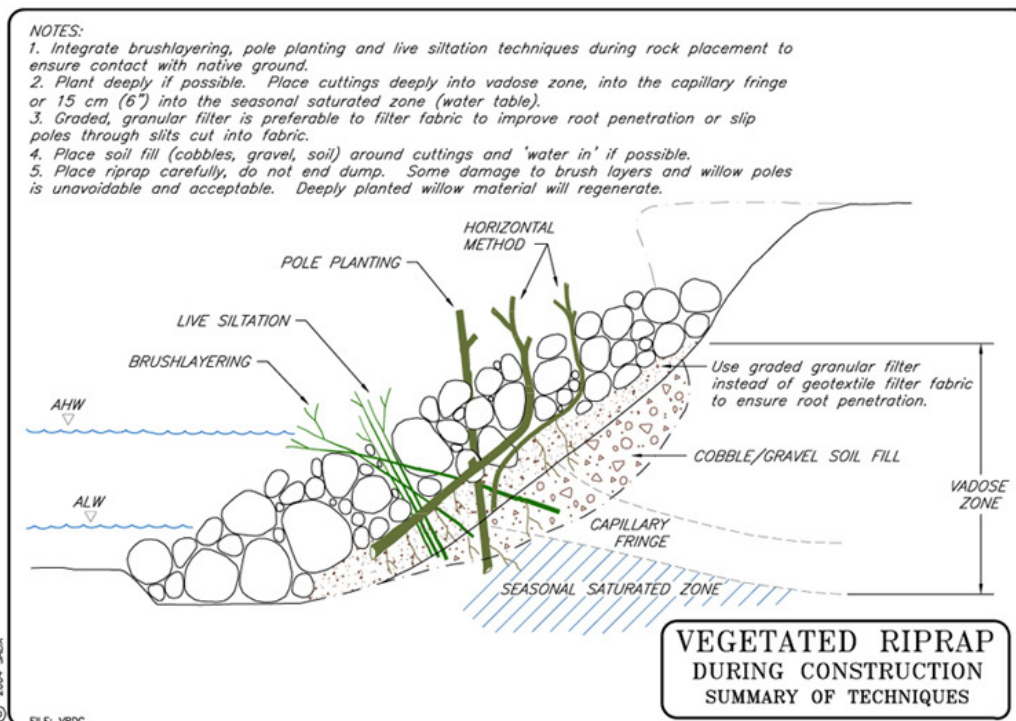

Figure 6.6. Vegetated riprap - construction techniques (McCullah and Gray 2005).

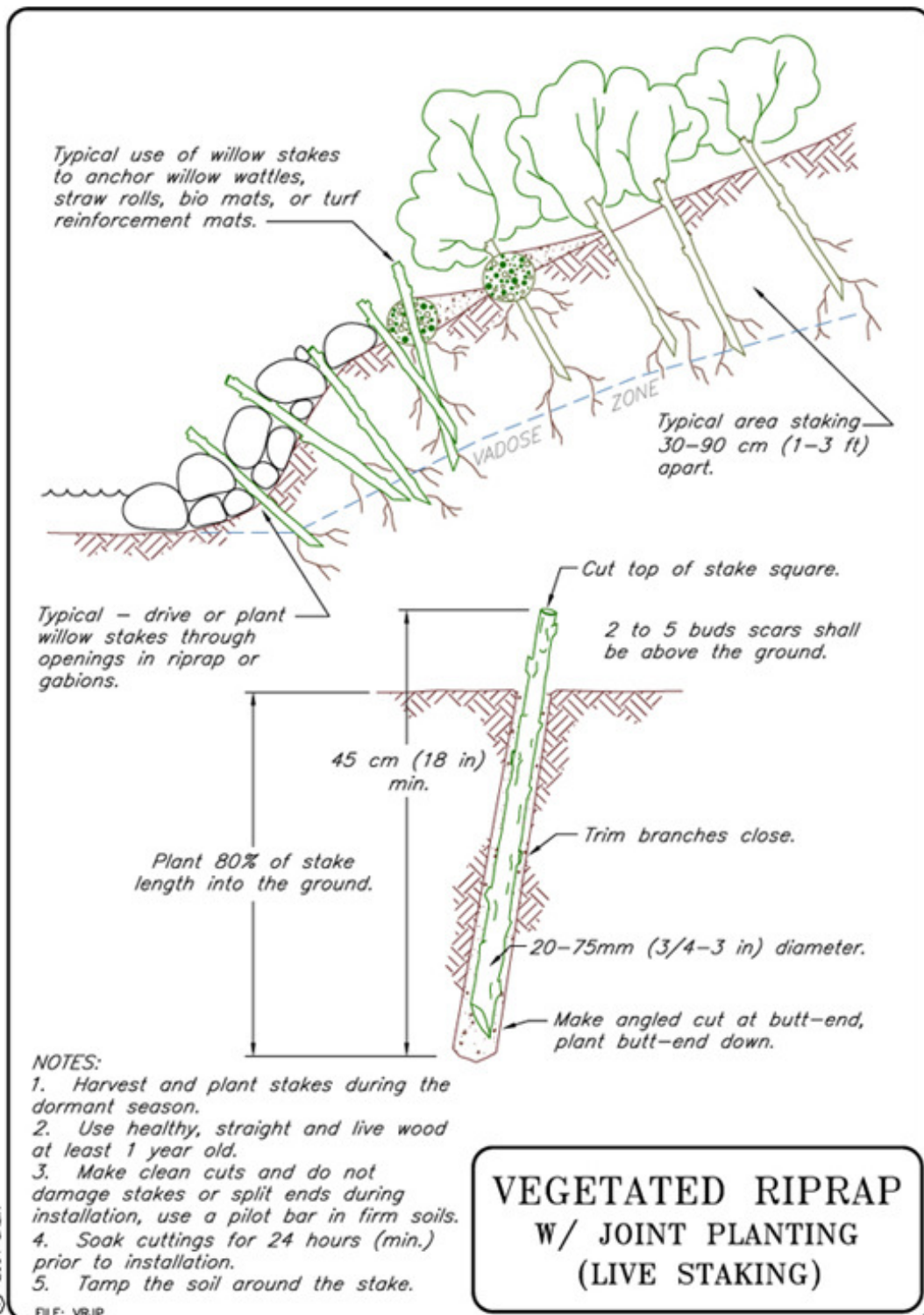

Figure 6.7. Vegetated riprap with joint planting (McCullah and Gray 2005).

The exclusive placement of predator-perching type habitat may not be appropriate where fish-rearing habitat is desired. In that situation, large rocks and logs located above the average high water line (AHW) might be replaced with shrubby-type protective vegetation. An additional environmental benefit is derived from the use of rock, as the surface area of the rocks is substrate that is available for colonization by invertebrates (Freeman and Fisichenich 2000). The small spaces between the rocks also provide benthic habitat and hiding places for small fish and fry.

6.8 APPLICATION GUIDANCE FOR BIOTECHNICAL COUNTERMEASURES

6.8.1 Streambank Zones

As indicated by U.S. Army Engineers Waterways Experiment Station (WES 1998), plants should be positioned in various elevational zones of the bank based on their ability to tolerate certain frequencies and durations of flooding, and their attributes of dissipating current- and wave-energies. The stream bank is generally broken into three or four zones to facilitate prescription of the biotechnical erosion control treatment. Because of daily and seasonal variations in flow, the zones are not precise and distinct. The zones are based on their bank position and are defined as the toe, splash, bank and overbank zones (Figure 6.8).

The *toe zone* is the area between the bed and the average normal stage. This zone is often under water more than six months of the year. It is a zone of high stress and is susceptible to undercutting and scour resulting in bank failure.

The *splash zone* is located between the normal high-water and normal low-water stages and is inundated throughout much of the year (at least six months). Water depths fluctuate daily, seasonally, and by location within the zone. This zone is also an area of high stress, being exposed frequently to wave-wash, erosive currents, ice and debris movement, wet-dry cycles, and freeze-thaw cycles.

Because the toe and splash zones are the zones of highest stress, these zones are treated as one zone with a structural revetment, such as rock, stone, logs, cribs, gabions, or some other 'hard' treatment. Within the splash zone, flood-resistant herbaceous emergent aquatic plants like reeds, rushes, and sedges may be planted in the structural element of the bank protection.

The *bank zone* is usually located above the normal high-water level, but is exposed periodically to wave-wash, erosive flows, ice and debris movement, and traffic by animals or man. This zone is inundated for at least a 60-day duration once every two to three years and is influenced by a shallow water table. Herbaceous (i.e., grasses, clovers, some sedges, and other herbs) and woody plants (i.e., willows, alder, and dogwood) that are flood tolerant and able to withstand partial to complete submergence for up to several weeks are used in this zone. Whitlow and Harris (1979) provide a listing of very flood-tolerant woody species and a few herbaceous species by geographic area within the United States.

The *overbank zone* includes the top bank area and the area inland from the bank zone, and is usually not subjected to erosive forces except during occasional flooding. Vegetation in this zone is extremely important for intercepting overbank floodwater, binding the soil in the upper bank together through its root system, helping reduce super-saturation of the bank, and decreasing the weight of unstable banks through evapotranspiration processes. This zone can contain grasses, herbs, shrubs, and trees that are less flood-tolerant than those in the bank zone. The rooting depth of trees can be an extremely important part of bank stability. Besides erosion control, wildlife habitat diversity, aesthetics, and access for project construction and long-term maintenance are important considerations in this zone.

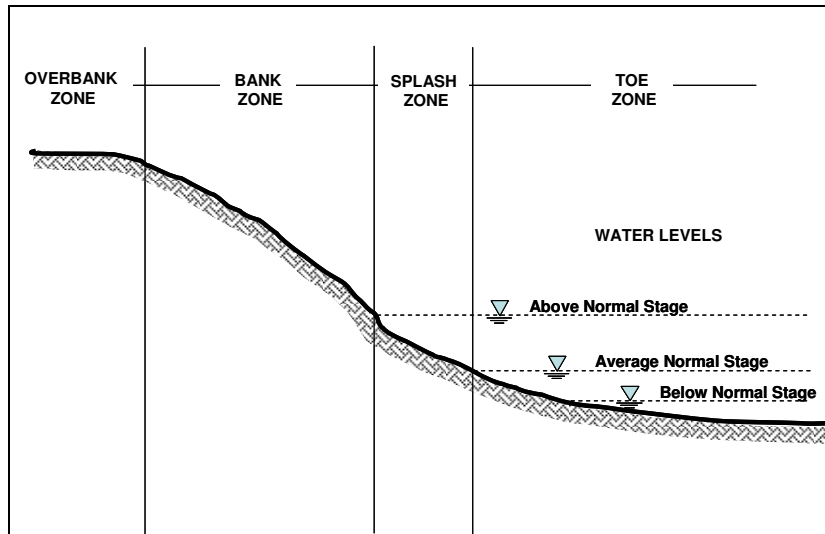

Figure 6.8. Bank zones defined for slope protection (WES 1998).

6.8.2 Biotechnical Engineering Treatments

Descriptions and guidelines for biotechnical engineering treatments or combinations of treatments, and plant species that can be used in the treatments are described in detail by WES (1998), Bentrup and Hoag (1998), and Schiechl and Stern (1997). The following is a brief summary of some of the major types of biotechnical engineering treatments that can be used separately or in some combination.

Toe Zone. Structural revetments such as riprap, gabions, cribs, logs, or root wads in a biotechnical engineering application are used at the toe in the zone below normal water levels and up to where normal water levels occur. There are no definitive guidelines for how far up the bank to extend the structural revetment. Instead, it is common practice to extend the revetment from below the predicted contraction and local scour depth up to at least where the water flows the majority of the year. Vegetative treatments are placed above or behind this structural toe protection (see Figures 6.1, 6.2, and 6.7).

Splash Zone. Several treatments may be used individually or in combination with other treatments in the splash zone above or behind the structural toe protection. These include coir rolls and mats, brush mattresses, wattles or fascines, brush layering, vegetative geogrid, dormant posts, dormant cuttings, and root pads.

Coir is a biodegradable geotextile fabric made of woven fibers of coconut husks and is formed into either rolls (coir roll) or mats (coir fiber mats). Coir rolls are often placed above the structural toe protection parallel to the bank with wetland vegetation planted or grown in the roll. Coir fiber mats are made in various thicknesses and are often prevegetated at a nursery with emergent aquatic plants or sometimes sprigged on-site with emergent aquatic plants harvested from local sources.

Brush mattresses, sometimes called brush matting or brush barriers, are a combination of a thick layer of long, interlaced live willow switches or branches and wattling. Wattling, also known as fascine, is a cigar-shaped bundle of live, shrubby material made from species that root rapidly from the stem. The branches in the mattress are placed perpendicular to the bank with their basal ends inserted into a trench at the bottom of the slope in the splash zone, just above the structural toe protection. The fascines are laid over the basal ends of the brush mattress in the ditch and staked. The mattress and fascines are kept in place by either woven wire or tie wire that is held in place by wedge-shaped construction stakes.

Both are covered with soil and tamped. Figures 6.1, 6.3, and 6.7 show examples of this type of treatment.

Brush layering, also called branch layering or branch packing, is used in the splash zone as well as in the bank zone. This treatment consists of live branches or brush that quickly sprout, such as willow or dogwood species, placed in trenches dug into the slope, on contour, with their basal ends pointed inward and the tips extending beyond the fill face. Branches should be arranged in a criss-cross fashion and covered with firmly compacted soil. This treatment can also be used in combination with live fascines and live pegs.

Vegetative geogrid is also used in the splash zone and can extend farther up into the bank zone and possibly the overbank zone. This system is also referred to as "fabric encapsulated soil" and consists of successive walls of several lifts of fabric reinforcement with intervening long, live willow whips. The fabric consists of two layers of coir fabric which provide both structural strength and resistance to piping of fine sediments.

Dormant post treatment consists of placing dormant, but living stems of woody species that sprout stems and roots from the stem, such as willow or cottonwood, in the splash zone and the lower part of the bank zone. Post holes are formed in the bank so that the end of the post is below the maximum predicted scour depth. Posts can also be planted in riprap revetments.

Dormant cuttings, also known as live stakes, consists of inserting and tamping live, single stem, rootable cuttings into the ground or sometimes geotextile substrates. In the splash zone of high velocity streams, this method is used in combination with other treatments, such as brush mattresses and root wads. Dormant cuttings can be used as live stakes in the brush mattress and fascines in the place of or in combination with the wedge-shaped construction stakes (Figures 6.1, 6.5, 6.6, and 6.7).

Root pads are clumps of shrubbery composed of woody species that are often placed in the splash zone between root wads (Figure 6.2). Root pads can also be used in the bank and overbank zones, but should be secured with stakes on slopes greater than 1V:6H.

Bank Zone. This zone can be stabilized with the treatments previously described as well as with sodding, mulching, or a combination of treatments. Sodding of flood-tolerant grasses can be used to provide rapid bank stabilization where only mild currents and wave action are expected. The sod usually must be held in place with some sort of wire mesh, geotextile mesh such as a coir fabric, or stakes. Coir mats may extend into this zone. Shrub-like woody transplants or rooted cuttings are also effective in this zone and are often placed in combination with tied-down and staked mulch that is used to temporarily reduce surface erosion. For areas where severe erosion or high currents are expected, methods such as brush mattress should be carried into the bank zone.

Contour wattling consists of fascines, often used independent of the brush mattress, placed along contours, and buried across the slope, parallel or nearly parallel to the stream course. The bundles can be living or constructed from wood and are staked to the bank. Contour wattles are often installed in combination with a coir fiber blanket over seed and a straw mulch to prevent the development of rills or gullies (WES 1998) (Figure 6.5).

Brush layering with some modifications can be used in the bank zone. Geotextile fabrics should be used between the brush layers and keyed into each branch layer trench to prevent unraveling of the bank between the layers (WES 1998).

Overbank Zone. Bioengineered treatments are generally not used in this zone except to control gullying or where slopes are greater than 1V:3H. In these cases, brush layering or contour wattling may be employed across the gully or on the contour of the slope.

Deep-rooting plants, such as larger flood-tolerant trees, are required in this zone in order to hold the bank together. Care should be taken in the placement of trees that may grow to be fairly large since their shade can kill out vegetation in the splash and bank zones. Trees planted in the overbank zone are planted either as container-grown or bare-root plants.

Depending on their shade tolerance, grasses, herbs, and shrubs can be planted between the trees. Hydroseeding and hydromulching are useful and effective means of direct seeding in the overbank zone.

6.9 SUMMARY

Biotechnical engineering can be a useful and cost-effective tool in controlling bank or channel erosion, while increasing the aesthetics and habitat diversity of the site. However, where failure of the countermeasure could lead to failure of a bridge or highway structure, the only acceptable solution in the immediate vicinity of a structure is a traditional, "hard" engineering approach. Biotechnical countermeasures need to be applied in a prudent manner, in conjunction with channel planform and bed stability-analysis, and rigorous engineering design. Designs must account for a multitude of factors associated with the geotechnical characteristics of the site, the local and watershed geomorphology, local soils, plant biology, hydrology, and site hydraulics. Finally, programs for monitoring and maintenance, which are essential to the success and effectiveness of any biotechnical engineering project, must be included in the project and strictly adhered to.

(page intentionally left blank)

CHAPTER 7

COUNTERMEASURE DESIGN GUIDELINES

7.1 INTRODUCTION

In Volume 2, design guidelines are provided for a variety of stream instability and bridge scour countermeasures. Most of these countermeasures have been applied successfully on a state or regional basis, but, in several cases, only limited design references are available in published handbooks, manuals, or reports. No attempt has been made to include in this document design guidelines for all the countermeasures listed in the matrix (Table 2.1). There are, however, references in Chapters 8 and 10 to publications that contain at least a sketch or photograph of a particular countermeasure, and in many cases contain more detailed design guidelines.

Countermeasure design guidelines formerly presented in HEC-20 (Lagasse et al. 2001a) (spurs, guide banks, drop structures) and in HEC-18 (Richardson and Davis 2001) (riprap at abutments and piers) are now consolidated in this document. Since many bridge scour and stream instability countermeasures require riprap revetment as an integral component of the countermeasure, riprap revetment design guidance is summarized in Design Guideline 4. An appropriate granular or geotextile filter is essential for any countermeasure requiring a protective armor layer (e.g., riprap, articulating concrete blocks, etc.). Filter design guidance is provided in Design Guideline 16.

A number of DOTs provided specifications, procedures, or design guidelines for bridge scour and stream instability countermeasures that have been used successfully locally, but for which only limited design guidance is available outside the agency. Several of these are presented as design guidelines for the consideration of and possible adaptation to the needs of other DOTs (see for example, Design Guideline 6, Wire Enclosed Riprap Mattress, and Design Guideline 13, Grout/Cement Filled Bags). These specifications, procedures, or guidelines have not been evaluated, tested, or endorsed by the authors of this document or by the FHWA. They are presented here in the interests of information transfer on countermeasures that **may** have application in another state or region.

Since publication of the Second Edition of HEC-23 in 2001, both the Transportation Research Board through the NCHRP Program and FHWA have sponsored a number of research projects to improve the state of practice in bridge scour and stream instability countermeasure technology and provide definitive guidance to bridge owners in countermeasure design. Among the projects that represent advances in countermeasure technology that have been incorporated into the Design Guidelines in Volume 2 are:

- NCHRP Report 544 - Environmentally Sensitive Channel and Bank Protection Measures (McCullah and Gray 2005)
- NCHRP Report 568 - Riprap Design Criteria, Recommended Specifications, and Quality Control (Lagasse et al. 2006)
- NCHRP Report 587 - Countermeasures to Protect Bridge Abutments from Scour (Barkdoll et al. 2007)
- NCHRP Report 593 - Countermeasures to Protect Bridge Piers from Scour (Lagasse et al. 2007)

7.2 DESIGN GUIDELINES

The following specifications, procedures, or design guidelines are included in Volume 2. The application of the countermeasure and the contributing source(s) of information are also indicated below.

7.2.1 Countermeasures for Stream Instability

Design Guideline 1

- **Bendway Weirs/Stream Barbs**
 - **Source(s):** Colorado Department of Transportation
Washington State Department of Transportation
Tennessee Department of Transportation
Soil Conservation Service (now Natural Resources Conservation Service)
U.S. Army Corps of Engineers
 - **Application:** Bankline protection and flow alignment in meandering channel bends

Design Guideline 2

- **Spurs**
 - **Source(s):** HEC-20 Stream Stability at Highway Structures (Second Edition)
NCHRP Report 568
 - **Application:** Bankline stabilization and flow alignment

Design Guideline 3

- **Check Dams/Drop Structures**
 - **Source(s):** HEC-20 Stream Stability at Highway Structures (Second Edition)
HEC-14 Hydraulic Design of Energy Dissipators for Culverts and Channels
 - **Application:** Correcting or preventing channel degradation

7.2.2 Countermeasures for Streambank and Roadway Embankment Protection

Design Guideline 4

- **Riprap Revetment**
 - **Source(s):** NCHRP Report 568
 - **Application:** Bankline/abutment protection and riprap component of many other countermeasures

Design Guideline 5

- **Riprap Design for Embankment Overtopping**
 - **Source(s):** NCHRP Report 568
 - **Application:** Protection for roadway approach embankments and flow control countermeasures

Design Guideline 6

- **Wire Enclosed Riprap Mattress**
 - **Source(s):** New Mexico State Highway and Transportation Department
 - **Application:** Revetment for banklines, guide banks, and sloping abutments

Design Guideline 7

- **Soil Cement**
 - **Source(s):** Portland Cement Association
Pima County Arizona
Maricopa County Arizona
 - **Application:** Revetment for banklines and sloping abutments, drop structures, and bed armor

Design Guideline 8

- **Articulating Concrete Block Systems for Bank Revetment or Bed Armor**
 - **Source(s):** Harris County Flood Control District (2001)
Federal Highway Administration
Maine Department of Transportation
Minnesota Department of Transportation
 - **Application 1:** Bankline revetment and bed armor

Design Guideline 9

- **Grout-Filled Mattresses for Bank Revetment or Bed Armor**
 - **Source(s):** Federal Highway Administration
 - **Application 1:** Bankline revetment and bed armor

Design Guideline 10

- **Gabion Mattresses for Bank Revetment or Bed Armor**
 - **Source(s):** Federal Highway Administration
 - **Application 1:** Bankline revetment and bed armor

7.2.3 Countermeasures for Bridge Pier Protection

Design Guideline 8

- **Articulating Concrete Block Systems at Bridge Piers**
 - **Source(s):** NCHRP Report 593
 - **Application 2:** Pier scour protection

Design Guideline 9

- **Grout-Filled Mattresses at Bridge Piers**
 - **Source(s):** NCHRP Report 593
 - **Application 2:** Pier scour protection

Design Guideline 10

- **Gabion Mattresses at Bridge Piers**
 - **Source(s):** NCHRP Report 593
 - **Application 2:** Pier Scour Protection

Design Guideline 11

- **Rock Riprap at Bridge Piers**
 - **Source(s):** HEC-18 Scour at Bridges (Third Edition)
NCHRP Report 593
NCHRP Report 568
 - **Application:** Pier scour protection

Design Guideline 12

- **Partially Grouted Riprap at Bridge Piers**
 - **Source(s):** NCHRP Report 593
 - **Application:** Pier Scour Protection

7.2.4 Countermeasures for Abutment Protection

Design Guideline 13

- **Grout/Cement Filled Bags**
 - **Source(s):** Maryland State Highway Administration
Maine Department of Transportation
 - **Application:** Protection of undermined areas at piers and abutments, and bed armor

Design Guideline 14

- **Rock Riprap at Bridge Abutments**
 - **Source(s):** NCHRP Report 568
NCHRP Report 587
 - **Application:** Abutment scour protection

Design Guideline 15

- **Guide Banks**
 - **Source(s):** HEC-20 Stream Stability at Highway Structures (Second Edition)
NCHRP Report 568
 - **Application:** Abutment scour protection

7.2.5 Filter Design

Design Guideline 16

- **Filter Design**
 - **Source(s):** NCHRP Report 568
NCHRP Report 593
 - **Application:** Filter for revetment or countermeasure armor

7.2.6 Special Applications

Design Guideline 17

- **Riprap Design for Wave Attack**
 - **Source(s):** HEC-25 (1st and 2nd Editions)
 - **Application:** Protection for coastal roadway embankments

Design Guideline 18

- **Riprap Protection for Bottomless Culverts**
 - **Source(s):** FHWA Reports FHWA-RD-02-078 and FHWA-HRT-07-026
 - **Application:** Scour protection at bottomless culverts

Design Guideline 19

- **Concrete Armor Units/Toskanes and A-Jacks®**
 - **Source(s):** Testing at Colorado State University
 - **Application:** Pier scour protection

CHAPTER 8

OTHER COUNTERMEASURES AND CASE HISTORIES OF PERFORMANCE

8.1 INTRODUCTION

Design Guidelines 1 through 19 contain specific design procedures for a variety of stream instability and bridge scour countermeasures that have been applied successfully on a state or regional basis. Other countermeasures such as retarder structures, longitudinal dikes, bulkheads, and even channel relocations may be used to mitigate scour at bridges or stream bank erosion. Some of these measures are discussed and general guidance is summarized in this chapter. Chapter 4 (Section 4.3.6) illustrates the use of the concept of radial stress on a meander bend to evaluate the performance of fence, dike, and retarder type structures in protecting an eroding bankline.

Case histories of hydraulic problems at bridge sites can provide information on the success (or failure) of the various countermeasures used to stabilize streams. This chapter also summarizes the evaluation of countermeasure performance compiled for FHWA from case histories at 224 bridge sites (Brice and Blodgett 1978).

8.2 HARDPOINTS

Hardpoints consist of stone fills spaced along an eroding bank line, protruding only short distances into the channel. A root section extends landward to preclude flanking. The crown elevation of hardpoints used by the USACE at demonstration sites on the Missouri River was generally at the normal water surface elevation at the toe, sloping up at a rate of about 1 ft in 10 ft (1 m in 10 m) toward the bank. Hardpoints are most effective along straight or relatively flat convex banks where the streamlines are parallel to the bank lines and velocities are not greater than 10 ft/s (3 m/s) within 50 ft (15 m) of the bank line. Hardpoints may be appropriate for use in long, straight reaches where bank erosion occurs mainly from a wandering thalweg at lower flow rates. They would not be effective in halting or reversing bank erosion in a meander bend unless they were closely spaced, in which case spurs, retarder structures, or bank revetment would probably cost less. Figure 8.1 is a perspective of a hardpoint installation. Hardpoints have been used effectively as the first "spur" in a spur field (see Design Guideline 2).

8.3 RETARDER STRUCTURES

Retarder structures are permeable or impermeable devices generally placed parallel to streambanks to reduce velocities and cause deposition near the bank. They are best suited for protecting low banks or the lower portions of streambanks. Retarder structures can be used to protect an existing bank line or to establish a different flow path or alignment. Retards do not require grading of the streambank, and they create an environment which is favorable to the establishment of vegetation.

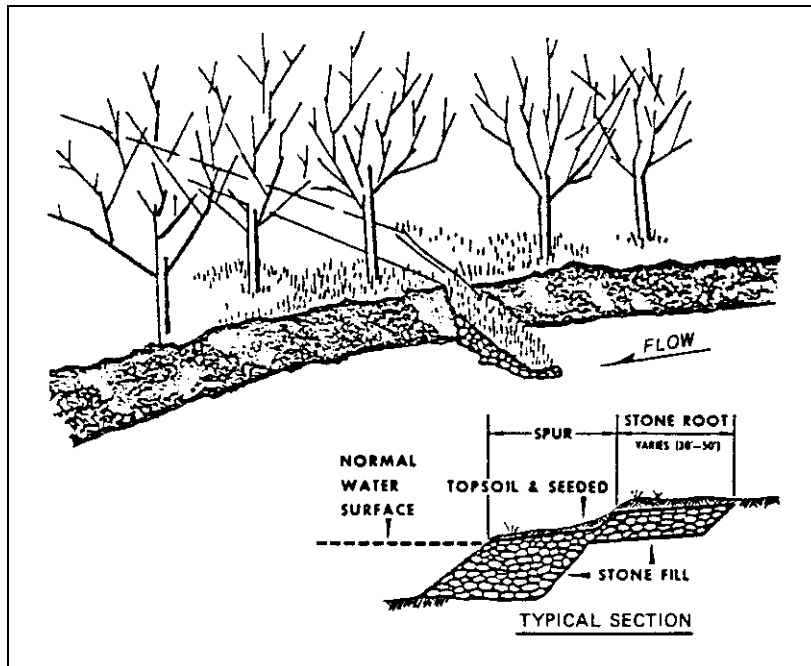

Figure 8.1. Perspective view of hardpoint installation with section detail (after Brown 1985).

8.3.1 Jacks and Tetrahedrons

Jacks most commonly consist of three linear members fixed together at their midpoints so that each member is perpendicular to the other two. Wires are strung on the members to resist distortion and to collect debris. Cables are used to tie individual jacks together and for anchoring key units to deadmen. Tetrahedrons consist of six members of equal length fixed together so as to form three faces, each of which is an equilateral triangle, i.e., a tetrahedron. The tetrahedron unit may be braced as shown in Figure 8.2 and wire mesh added to enhance flow retardance. Tetrahedrons are not as widely used as are jacks.

Jacks and tetrahedrons are effective in protecting banks from erosion only if light debris collects on the structures thereby enhancing their performance in retarding flow. However, heavy debris and ice can damage the structures severely. They are most effective on mild bends and in wide, shallow streams which carry a large sediment load.

Where jacks are used to stabilize meandering streams, both lateral and longitudinal rows are often installed to form an area retarder structure rather than a linear structure. Lateral rows of jacks are usually oriented in a downstream direction from 45° to 70°. Spacing of the lateral rows of jacks may be 50 to 200 ft (15 to 75 m) depending on the debris and sediment load carried by the stream. A typical jack unit is shown in Figure 8.3 and a typical area installation is shown in Figure 8.4.

Outflanking of jack installations is a common problem. Adequate transitions should be provided between the upstream bank and the structure, and the jack field should be extended to the overbank area to retard flow velocities and provide additional anchorage. Jacks are not recommended for use in corrosive environments or at locations where they would constitute a hazard to recreational use of the stream.

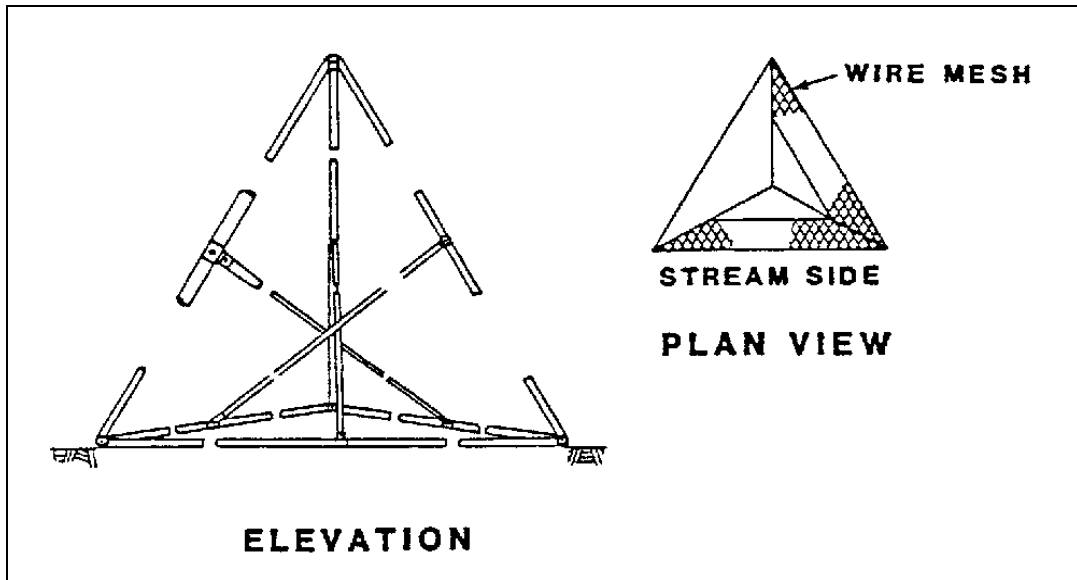

Figure 8.2. Typical tetrahedron design (after Brown 1985).

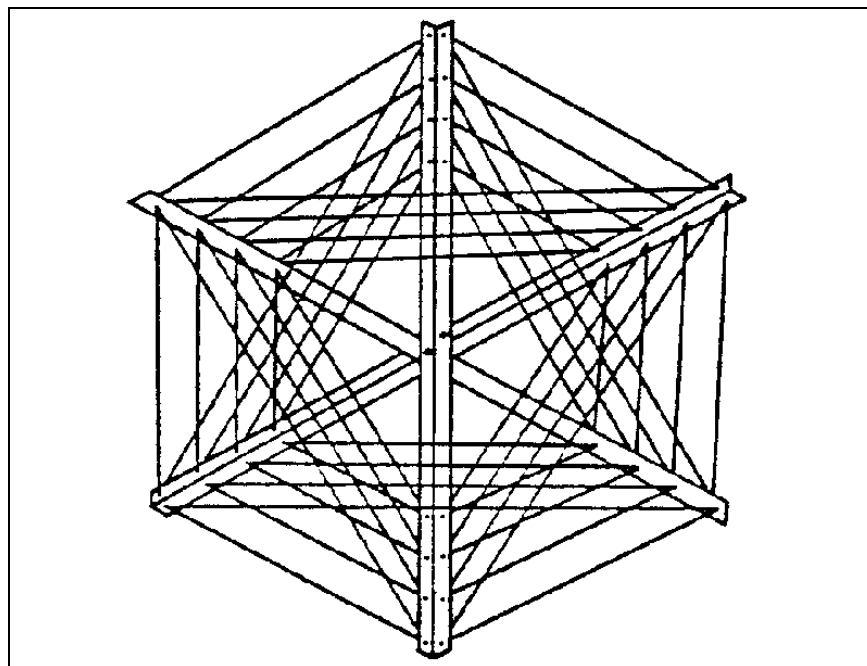

Figure 8.3. Typical jack unit (after Brown 1985).

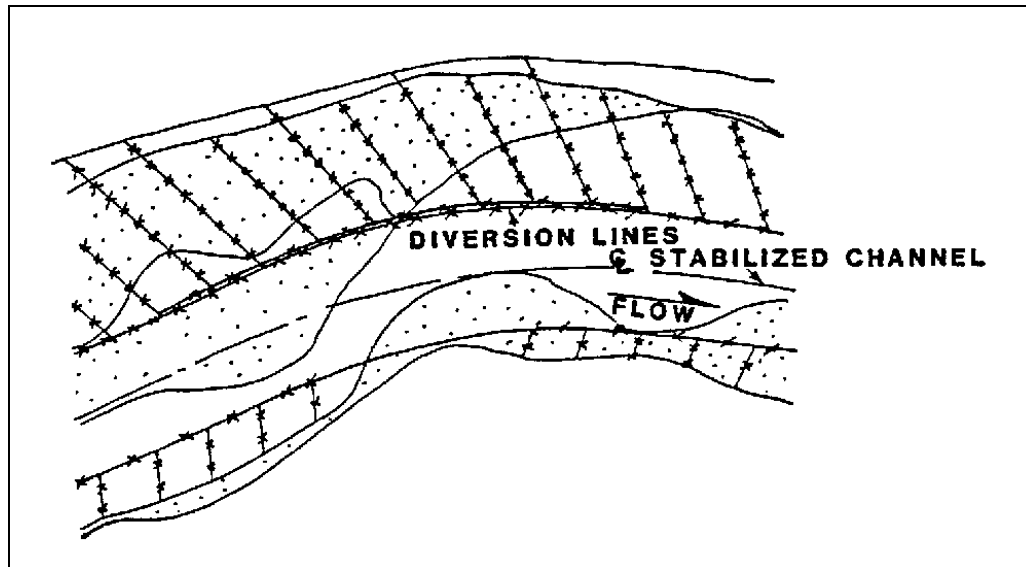

Figure 8.4. Retarder field schematic (after HDS 6, Richardson et al. 2001).

8.3.2 Fence Retarder Structures

Fence retarder structures provide protection to the lower portions of banks of relatively small streams. Posts may be of wood, steel, or concrete and fencing may be composed of wood planks or wire.

Scour and the development of flow channels behind linear structures are common causes of failure of longitudinal fences. Scour at the supporting members of the structure can be reduced by placing rock along the fence or the effects of scour can be overcome by driving supporting members to depths below expected scour. Tiebacks can be used to retard velocities between the linear structure and the streambank, thus reducing the ability of the stream to develop flow channels behind the structure.

8.3.3 Timber Pile

Timber pile retarder structures may be of a single, double, or triple row of piles with the outside of the upstream row faced with wire mesh or other fencing material. They have been found to be effective at sharp bends in the channel and where flows are directly attacking a bank. They are effective in streams which carry heavy debris and ice loads and where barges or other shipping vessels could damage other countermeasures or a bridge. As with other retarder structures, protection against scour failure is essential. Figure 8.5 illustrates a design.

8.3.4 Wood Fence

Wood fence retarder structures have been found to provide a more positive action in maintaining an existing flow alignment and to be more effective in preventing lateral erosion at sharp bends than other retarder structures. Figure 8.6 is an end view of a typical wood fence design with rock provided to protect against scour.

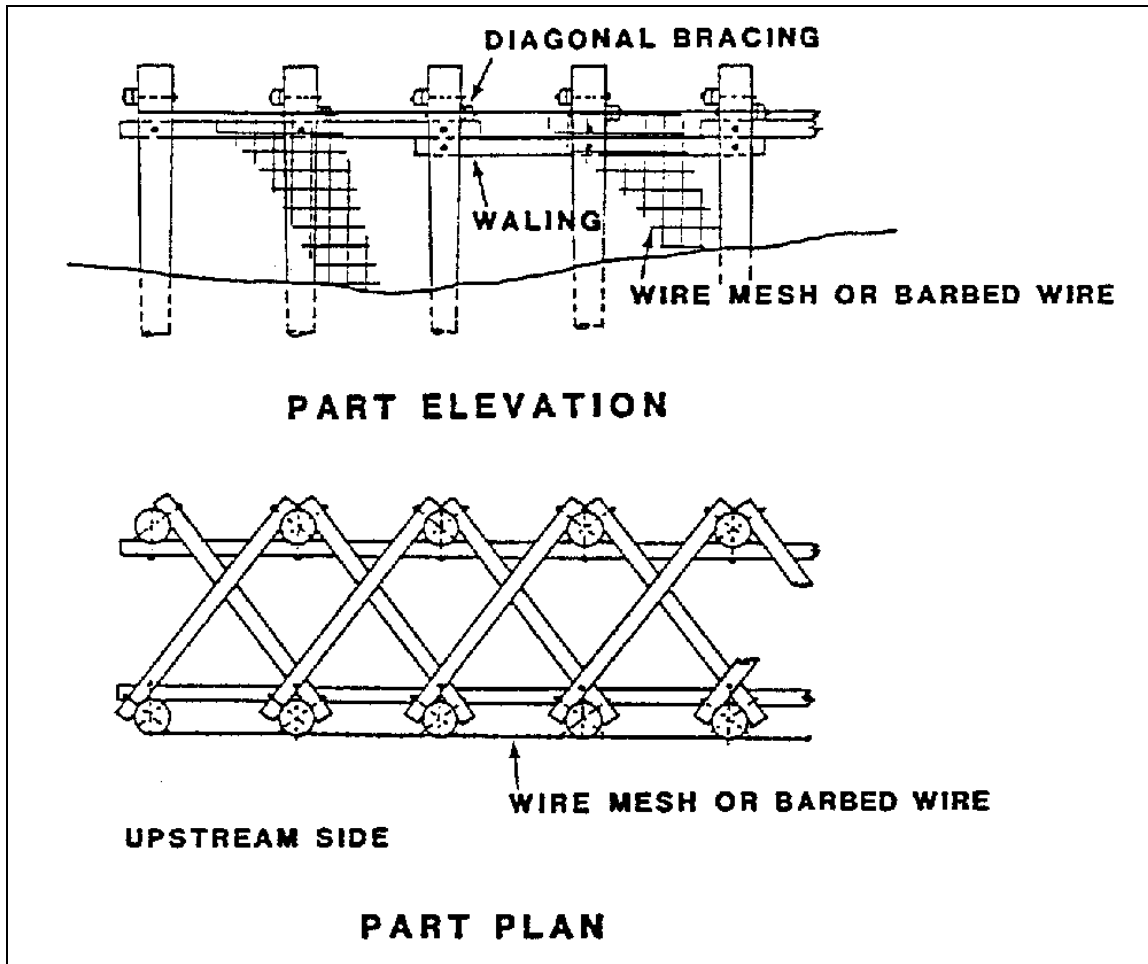

Figure 8.5. Timber pile bent retarder structure (after Brown 1985).

Wire fence retarder structures may be of linear or area configuration, and linear configurations may be of single or multiple fence rows. Double-row fence retards are sometimes filled with brush to increase the flow retardance. Figures 8.7 and 8.8 illustrate two types of wire fence retarder structures.

8.4 LONGITUDINAL DIKES

Longitudinal dikes are essentially impermeable linear structures constructed parallel with the streambank or along the desired flow path. They protect the streambank in a bend by moving the flow current away from the bank. Longitudinal dikes may be classified as earth or rock embankment dikes, crib dikes, or rock toe-dikes.

8.4.1 Earth or Rock Embankments

As the name implies, these dikes are constructed of earth with rock revetment or of rock. They are usually as high or higher than the original bank. Because of their size and cost, they are useful only for large-scale channel realignment projects.

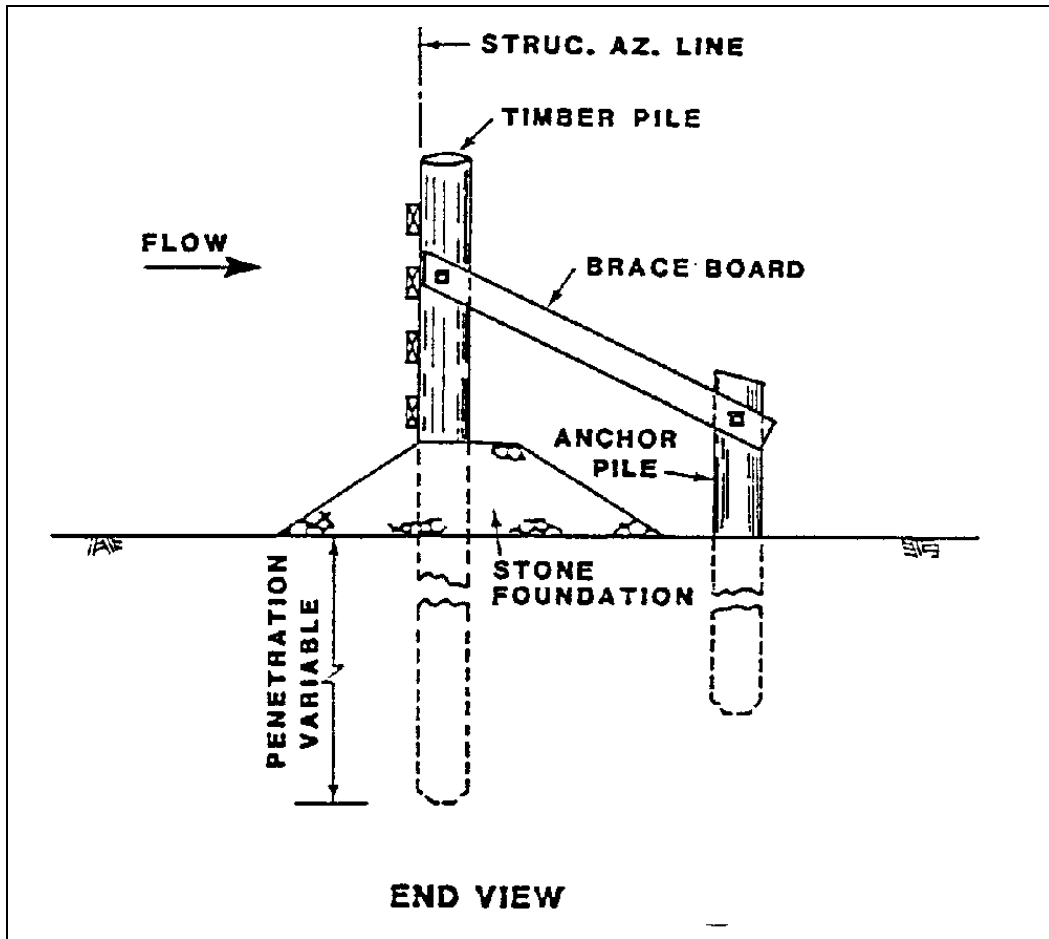

Figure 8.6. Typical wood fence retarder structure (modified from USACE 1981, after Brown 1985).

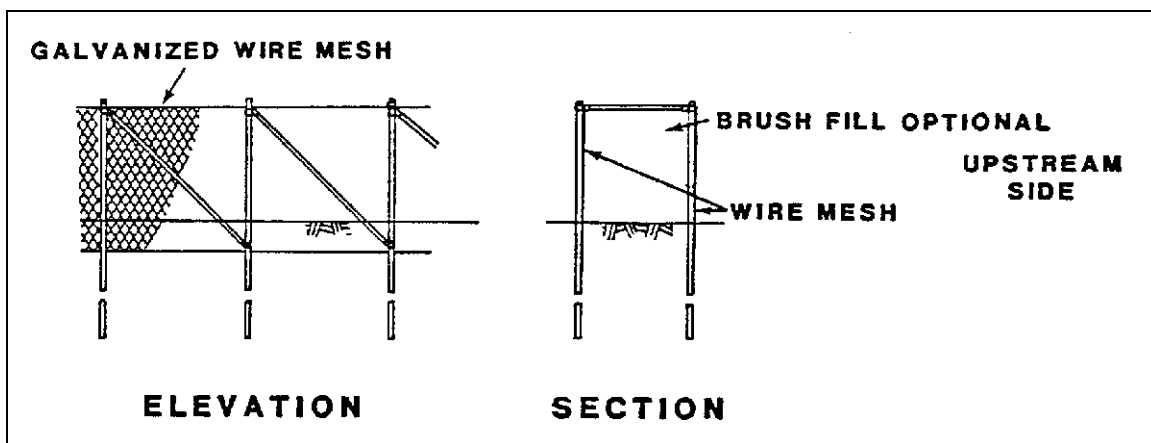

Figure 8.7. Light double row wire fence retarder structure (after Brown 1985).

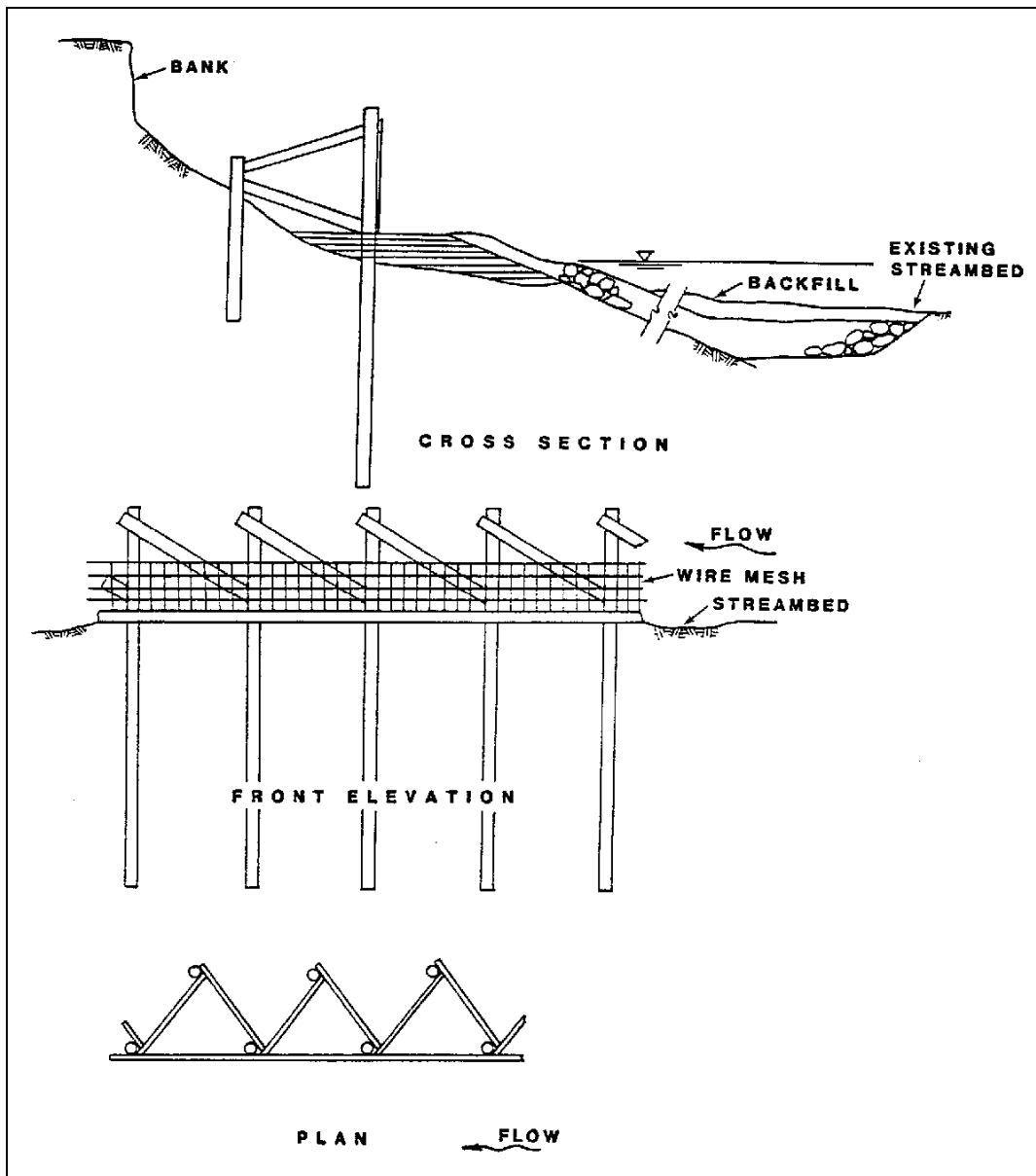

Figure 8.8. Heavy timber-pile and wire fence retarder structures (Modified from USACE 1981, after Brown 1985).

8.4.2 Rock Toe-Dikes

Rock toe-dikes are low structures of rock riprap placed along the toe of a channel bank. They are useful where erosion of the toe of the channel bank is the primary cause of the loss of bank material. The USACE has found that longitudinal stone dikes provide the most successful bank stabilization measure studied for channels which are actively degrading and for those having very dynamic beds. Where protection of higher portions of the channel bank is necessary, rock toe-dikes have been used in combination with other measures such as vegetative cover and retarder structures.

Figure 8.9 shows the typical placement and sections of rock toe-dikes. The volume of material required is 1.5 to 2 times the volume of material that would be required to armor the sides of the anticipated scour to a thickness of 1.5 times the diameter of the largest stone specified. Rock sizes should be similar to those specified for riprap revetments (see Design Guideline 4). Tiebacks are often used with rock toe-dikes to prevent flanking, as illustrated in Figure 8.10. Tiebacks should be used if the toe-dike is not constructed at the toe of the channel bank.

Rock toe-dikes are useful on channels where it is necessary to maintain as wide a conveyance channel as possible. Where this is not important, spurs could be more economical since scour is a problem only at the end projected into the channel. However, spurs may not be a viable alternative in actively degrading streams (Design Guideline 2).

8.4.3 Crib Dikes

Longitudinal crib dikes consist of a linear crib structure filled with rock, straw, brush, automobile tires or other materials. They are usually used to protect low banks or the lower portions of high banks. At sharp bends, high banks would need additional protection against erosion and outflanking of the crib dike. Tiebacks can be used to counter outflanking.

Crib dikes are susceptible to undermining, causing loss of material inside the crib, thereby reducing the effectiveness of the dike in retarding flow. Figure 8.11 illustrates a crib dike with tiebacks and a rock toe on the stream side to prevent undermining.

8.4.4 Bulkheads

Bulkheads are used for purposes of supporting the channel bank and protecting it from erosion. They are generally used as protection for the lower bank and toe, often in combination with other countermeasures that provide protection for higher portions of the bank. Bulkheads are most frequently used at bridge abutments as protection against slumping and undermining at locations where there is insufficient space for the use of other types of bank stabilization measures, and where saturated fill slopes or channel banks cannot otherwise be stabilized.

Bulkheads are classified on the basis of construction methods and materials. They may be constructed of concrete, masonry, cribs, sheet metal, piling, reinforced earth, used tires, gabions, or other materials. They must be protected against scour or supported at elevations below anticipated total scour, and where sections of the installation are intermittently above water, provisions must be made for seepage through the wall. Some bulkhead types, such as crib walls and gabions, should be provided with safeguards against leaching of materials from behind the wall.

Bulkheads must be designed to resist the forces of overturning, bending and sliding, either by their mass or by structural design. Figure 8.12 illustrates anchorage schemes for a sheetpile bulkhead. Because of costs, they should be used as countermeasures against meander migration only where space is not available to construct other types of measures.

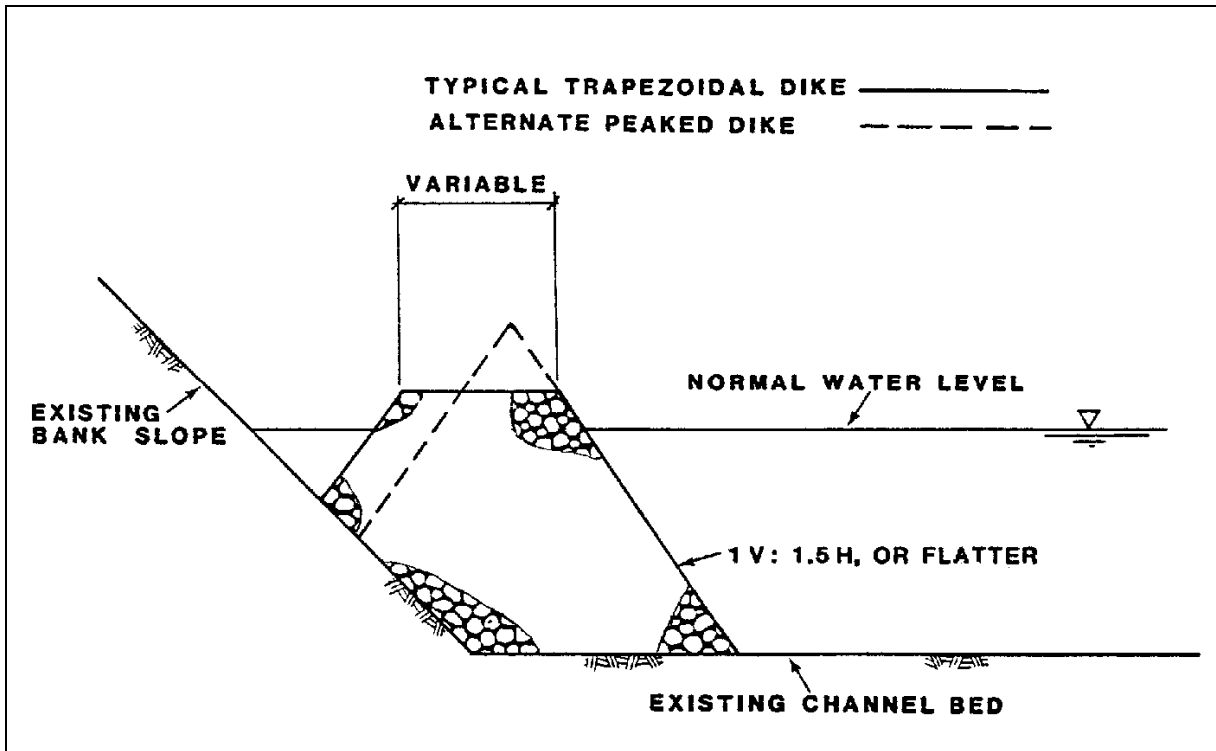

Figure 8.9. Typical longitudinal rock toe-dike geometries (after Brown 1985).

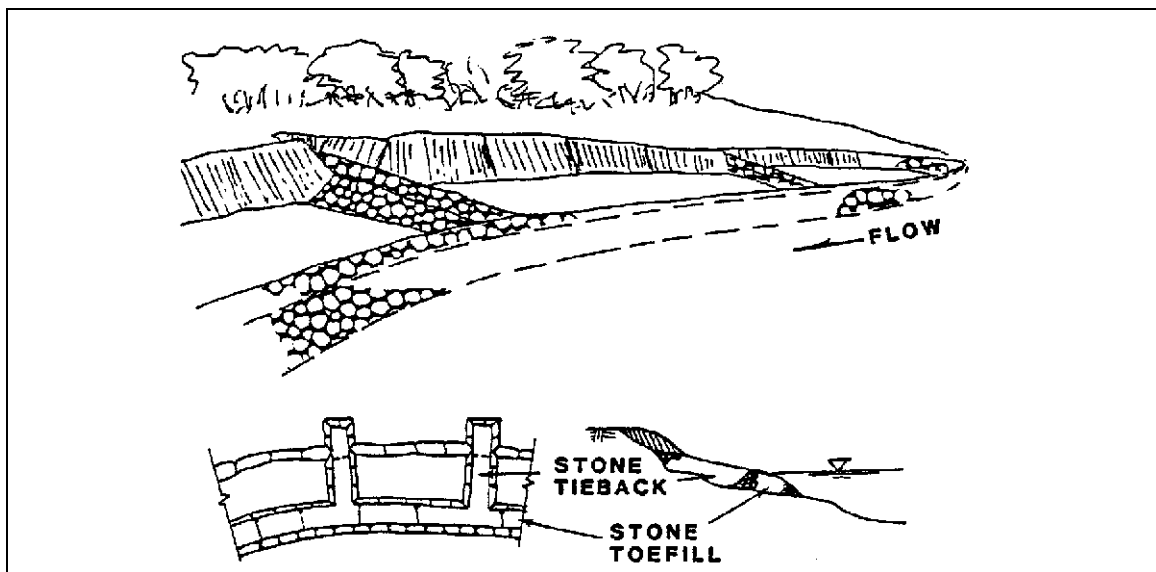

Figure 8.10. Longitudinal rock toe-dike tiebacks (after Brown 1985).

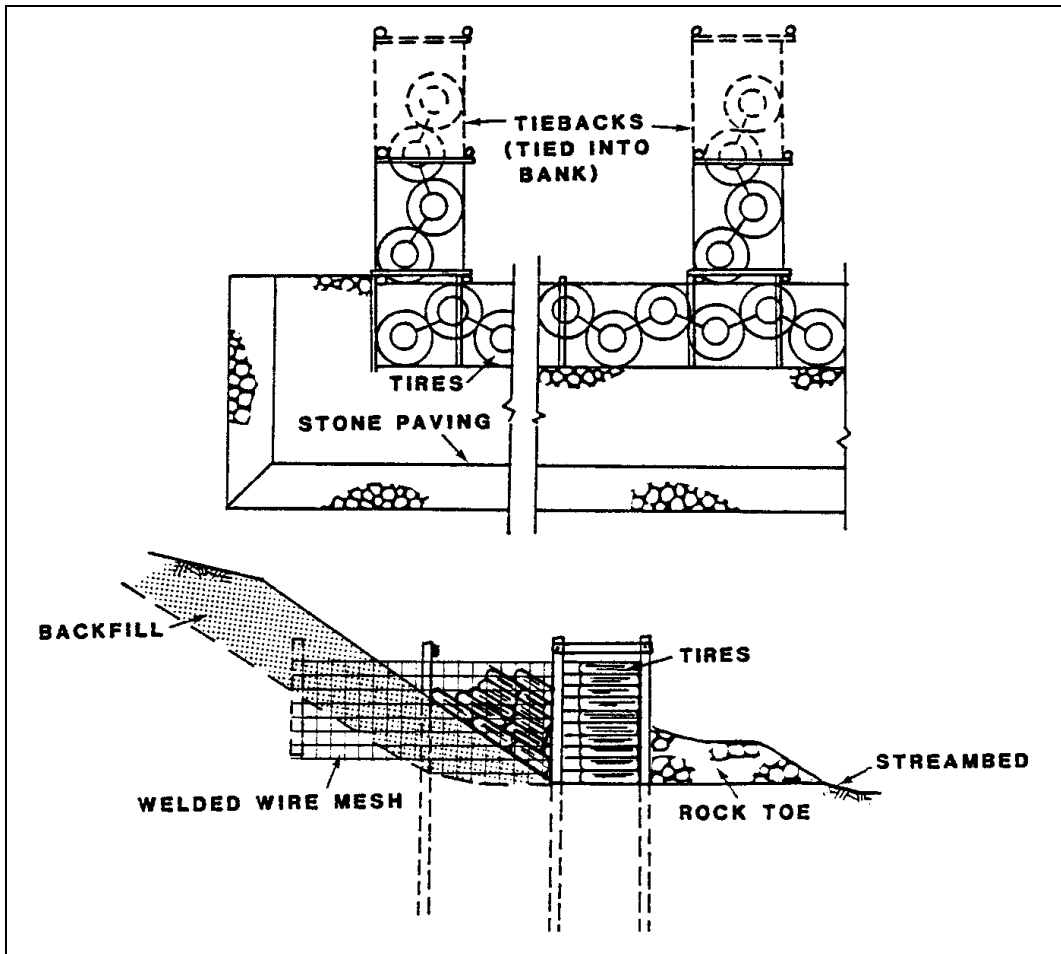

Figure 8.11. Timber pile, wire mesh crib dike with tiebacks (modified from USACE 1981, after Brown 1985).

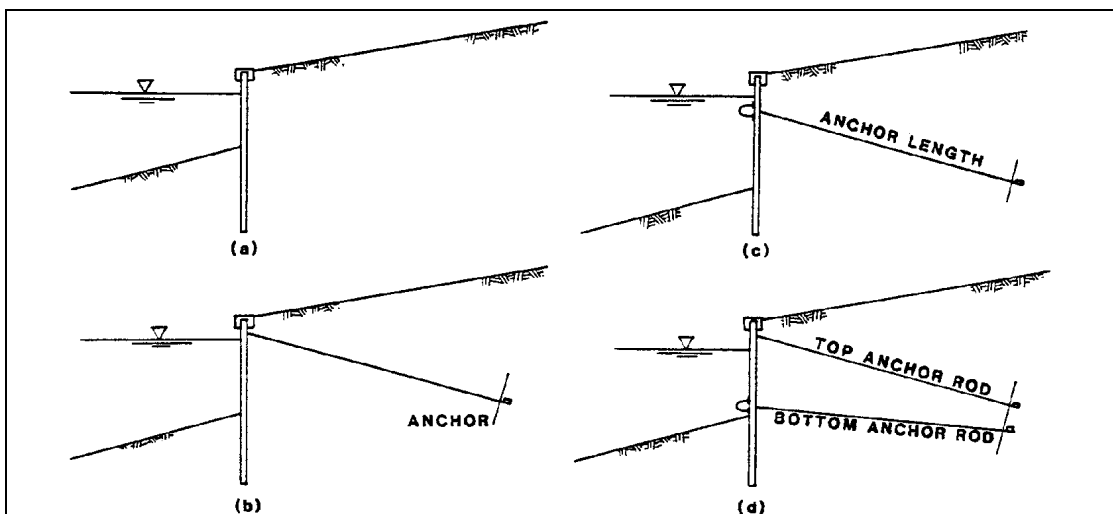

Figure 8.12. Anchorage schemes for a sheetpile bulkhead (after Brown 1985).

8.5 CHANNEL RELOCATION

At some locations, it may be advantageous to realign a stream channel, either in combination with the use of other countermeasures against meander migration or in lieu of other countermeasures.

Figure 8.13 illustrates hypothetical highway locations fixed by considerations other than stream stability. To create better flow alignment with the bridge, consideration could be given to channel realignment as shown in this figure (parts a and b). Similarly, consideration for realignment of the channel would also be advisable for a hypothetical lateral encroachment of a highway as depicted in part c of the figure. In either case, criteria are needed to establish the cross-sectional dimensions.

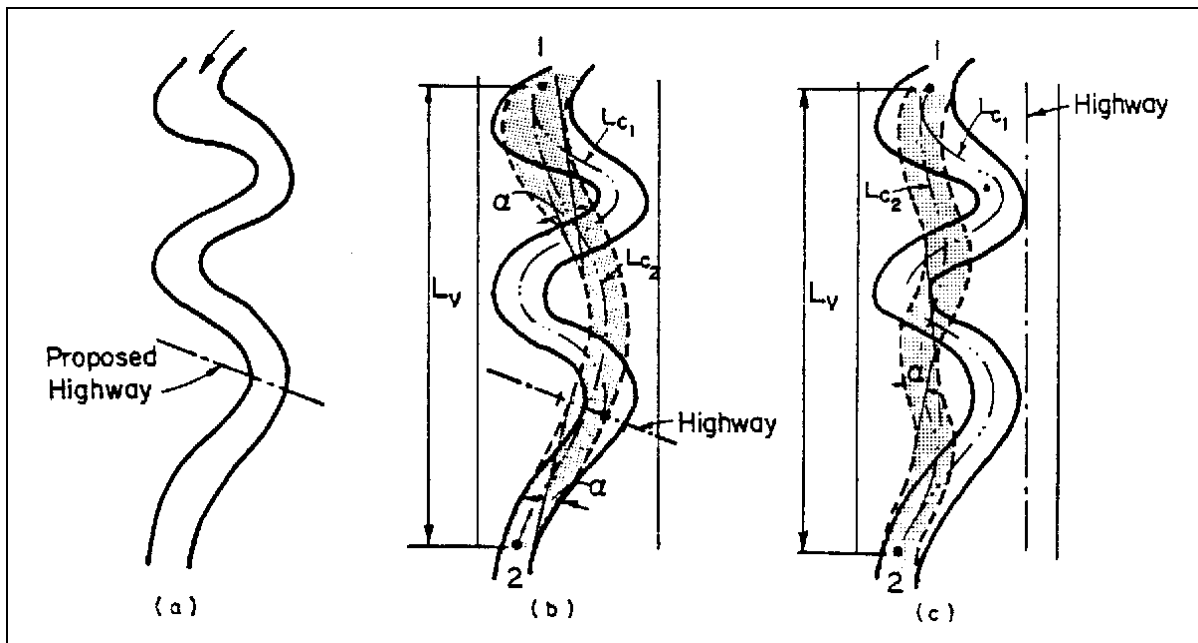

Figure 8.13. Encroachments on meandering streams (after HDS 6, Richardson et al. 2001).

Before realigning a stream channel, the stability of the existing channel must be examined. The stream classification, recent and older aerial photographs, and field surveys are necessary. The realigned channel may be made straight without curves, or may include one or more curves. If curves are included, decisions regarding the radius of curvature, the number of bends, the limits of realignment (hence the length and slope of the channel) and the cross-sectional area have to be made. Different streams have different historical backgrounds and characteristics with regard to bend migration, discharge, stage, geometry, and sediment transport, and an understanding and appreciation of river hydraulics and morphology is important to decision making. It is difficult to state generalized criteria for channel relocation applicable to all streams. HEC-20 (Lagasse et al. 2001a) provides quantitative techniques for evaluating and predicting lateral channel migration and analyzing vertical channel stability, as well as an introduction to channel restoration concepts that should be considered for channel relocation projects.

Based on a study of the stability of relocated channels, Brice presented the following recommendations and conclusions regarding specific aspects of planning and construction of channel realignment (Brice 1981):

- Channel Stability Prior to Realignment.

Assessment of the stability of a channel prior to realignment is needed to assess the risk of instability. An unstable channel is likely to respond unfavorably. Bank stability is assessed by field study and by stereoscopic examination of aerial photographs (see HEC-20). The most useful indicators of bank instability are cut or slumped banks, fallen trees along the bank line, and exposed wide point bars. Bank recession rates are measured by comparison of time-sequential aerial photographs. Vertical instability is equally important but more difficult to determine. It is indicated by changes in channel elevation at bridges and gaging stations. Serious degradation is usually accompanied by generally cut or slumped banks along a channel and by increased debris transport.

- Erosional Resistance of Channel Boundary Materials.

The stability of a channel, whether natural or relocated, is partly determined by the erosional resistance of materials that form the wetted perimeter of the channel (see HEC-20). Resistant bedrock outcrops in the channel bottom or that lie at shallow depths will provide protection against degradation, but not all bedrock is resistant. Erosion of shale, or of other sedimentary rock types interbedded with shale, has been observed. Degradation is not a problem at most sites where bed sediment is of cobble and boulder size. However, degradation may result from the relocation of any alluvial channel, whatever the size of bed material, but the incidence of serious degradation of channels relocated by DOTs is small in number. The erosional resistance of channel beds tends to increase with clay content. Banks of weakly cohesive sand or silt are clearly subject to rapid erosion, unless protected with vegetation. No consistent relation has been found between channel stability and the cohesion of bank materials, probably because of the effects of vegetation.

- Length of Realignment.

The length of realignment contributes significantly to channel instability at sites where its value exceeds 250 channel widths. When the value is below 100 channel widths, the effects of length of relocation are dominated by other factors. The probability of local bank erosion at some point along a channel increases with the length of the channel. The importance of vegetation, both in appearance and in erosion control, would seem to justify a serious and possibly sustained effort to establish it as soon as possible on graded banks.

- Bank Revetment.

Revetment makes a critical contribution to stability of relocated stream channels at many sites. Rock riprap is by far the most commonly used and effective revetment (see Design Guideline 4). Concrete slope paving is prone to failure. Articulating concrete block is effective where vegetation can establish within the open cells of the blocks (Design Guideline 8).

- Check Dams (drop structures).

In general, check dams are effective in preventing channel degradation in relocated channels. The potential for erosion at a check dam depends on its design and construction, its height and the use of revetment on adjoining banks. A series of low check dams, less than about 1.5 ft (0.5 m) in height, is probably preferable to a single higher structure, because of increased safety and reduced potential for erosion and failure. By simulating rapids, low check dams may add visual interest to the flow in a channel. One critical problem arising with check dams relates to improper design for large flows. Higher flows have worked around the ends of many installations to produce failure (see Design Guideline 3).

- Maintenance.

Problems which could be resolved by routine maintenance were observed along relocated channels. These were problems with the growth of annual vegetation, reduction of channel conveyance by overhanging trees, local bank cutting, and bank slumping. The expense of routine maintenance or inspection of relocated channels beyond the highway right-of-way may be prohibitive; however, most of the serious problems could be detected by periodic inspection, perhaps by aerial photography, during the first five to ten years after construction. Hydraulic engineers responsible for the design of relocated stream channels should monitor their performance to gain experience and expertise.

8.6 CASE HISTORIES OF COUNTERMEASURE PERFORMANCE

Case histories of hydraulic problems at bridge sites can provide information on the relative success of the various countermeasures used to stabilize streams. The following case histories are taken from Brice and Blodgett (1978), Brice (1984), and Brown et al. (1980). Site data are from Brice and Blodgett (1978). This compilation of case histories at 224 bridge sites is recommended reference material for those responsible for selecting countermeasures for stream instability. Additional case histories are given in HDS 6 (Richardson et al. 2001).

8.6.1 Flexible Revetment

Rock Riprap. Dumped rock riprap is the most widely used revetment in the United States. Its effectiveness has been well established where it is of adequate size, of suitable size gradation, and properly installed. Brice and Blodgett (1978) documented the use of rock riprap at 110 sites (Volume 1, Table 2). They rated the performance at 58 sites and found satisfactory performance at 34 sites, partially satisfactory performance at 12 sites, and failure to perform satisfactorily at 12 sites. Keeley concluded that riprap used in Oklahoma performed without significant failure and provides basic and efficient bank control on the meandering streams in Oklahoma (Keeley 1971). Additional discussion of riprap revetment failure modes and inspection guidance can be found in Chapter 5 and Appendix D.

A review of the causes of failure at the sites studied by Brice and Blodgett (1978) is instructive. They found the absence of a filter blanket clearly the cause of the failure at a site subject to tides and wave action. The riprap was placed on a fill of sand and fine gravel which eroded through the interstices of the riprap.

Internal slope failure was the cause of failure of riprap at the abutment of bridges at two sites. At one site, failure was attributed to saturation of a high fill by impounded water in a reservoir. Wave action also probably contributed to the failure. The other site is difficult to include as a riprap failure because the rock was not placed as riprap revetment. Thirty-three freight car loads of rock were dumped as an emergency measure to stop erosion at a bridge abutment during high-flow releases from a reservoir. The rock was displaced, and the high streambanks and highway fill were still susceptible to slumps. At both sites, riprap failed to prevent slumps in high fills.

Inadequate rock size and size gradation was given as the cause of failure at eight sites. All of these sites are complex, and it is difficult to assign failure to one cause, but rock size was definitely a factor.

Channel degradation accounted for failure at three sites in Mississippi. Channel degradation at these sites is due to channel straightening and clearing by the SCS (NRCS) and USACE. Riprap installations on the streambanks, at bridge abutments and in the streambed have failed to stop lateral erosion. At one site, riprap placed on the banks and bed of the stream resulted in severe bed scour and bank erosion downstream of the riprap.

Failure of riprap at one site was attributed to the steep slope on which the riprap was placed. At this site, rock riprap failed to stop slumping of the steep banks downstream of a check dam in a degrading stream.

Successful rock riprap installations at bends were found at five sites. Bank erosion was controlled at these sites by rock riprap alone. Installations rated as failing were damaged at the toe and upstream end, indicating inadequate design and/or construction, and damage to an installation of rounded boulders, indicating inadequate attention to riprap specifications. Other successful rock riprap study sites were sites where bank revetment was used in conjunction with other countermeasures, such as spurs or retards. The success of these installations was attributed more to the spurs or retards, but the contribution of the bank revetment was not discounted.

Broken Concrete. Broken concrete is commonly used in emergencies and where rock is unavailable or very expensive. No specifications were found for its use. Performance was found to be more or less unsatisfactory at three sites.

Rock-and-Wire Mattress and Gabions. The distinction made between rock-and-wire mattress and gabions is in the dimensions of the devices (see Design Guideline 10). Rock-and-wire mattress is usually 1.0 ft (0.3 m) or less in thickness and a gabion is thicker and nearly equidimensional. The economic use of rock-and-wire mattress is favored by an arid climate, availability of stones of cobble size, and unavailability of rock for dumped rock riprap. Corrosion of wire mesh is slow in arid climates, and ephemeral streams do not subject the wire to continuous abrasion. Where large rock is not available, the use of rock-and-wire mattress may be advantageous in spite of eventual corrosion or abrasion of the wire.

Rock-and-wire mattress performance was found to be generally satisfactory although local failure of the wire mesh and spilling out of the rock was not uncommon. Mattresses are held in place against the bank by railroad rails at sites in New Mexico and Arizona where good performance was documented (see Design Guideline 6). This is known locally as "railbank protection." The steel rail supported rock-and-wire mattress stays in place better than dumped rock riprap on the unstable vertical banks found on the ephemeral streams of this area. Mattress held in place by stakes has been found to be effective in Wyoming.

The use of rock-and-wire mattress has diminished in California because of the questionable service of wire mesh, the high cost of labor for installation, and the efficiency of modern methods of excavating for dumped riprap toe protection. The Los Angeles Flood Control District, however, has had installations in-place for 15 years or more with no evidence of wire corrosion. On the other hand, Montana and Maryland reported abrasion damage of wire. These experiences illustrate that economical use of countermeasures is dependent on the availability of materials, costs, and the stream environment in which the measure is placed.

Several sites were identified where gabions were installed, but the countermeasures had been tested by floods at only one site where gabions placed on the downstream slope of a roadway overflow section performed satisfactorily.

Other Flexible Revetment. Favorable performance of precast-concrete blocks at bridges was reported in Louisiana. Vegetation is reported to grow between blocks and contribute to appearance and stability. Vegetation apparently is seldom used alone at bridges. Iowa relies on sod protection of spur dikes, but Arkansas reported failure of sod as bank protection.

8.6.2 Rigid Revetments

Failure of rigid revetment tends to be progressive; therefore, special precautions to prevent undermining at the toe and termini and failure from unstable soils or hydrostatic pressure are warranted.

Concrete Pavement. Well-designed concrete paving is satisfactory as fill slope revetment, as revetment on streams having low gradients, and in other circumstances where it is well protected against undermining at the toe and ends. The case histories include at least one location where riprap launching aprons were successful in preventing undermining at the toe from damaging the concrete pavement revetment. Weep holes for relief of hydrostatic pressure are required for many situations (see Design Guideline 4).

Documented causes of failure in the case histories are undermining at the toe (six sites), erosion at termini (five sites), eddy action at downstream end (two sites), channel degradation (two sites), high water velocities (two sites), overtopping (two sites), and hydrostatic pressure (one site). Good success is reported with concrete slope paving in Florida, Illinois, and Texas.

Sacked Concrete. No DOT reported a general use of sacked concrete as revetment. California was reported to regard this as an expensive revetment almost never used unless satisfactory riprap was not available. Sacked concrete revetment failures were reported from undermining of the toe (two sites), erosion at termini (one site), channel degradation (two sites), and wave action (one site) (see Design Guideline 4).

Concrete-Grouted Riprap. Fully-grouted riprap permits the use of smaller rock, a lesser thickness, and more latitude in gradation of rock than in dumped rock riprap. No failures of grouted riprap were documented in the case histories, but it is subject to the same types of failures as other rigid revetments (see Chapter 5, Section 5.6 and Design Guideline 12).

Concrete-Filled Fabric Mat. Concrete-filled fabric mat is a patented product (Fabriform) consisting of porous, pre-assembled nylon fabric forms which are placed on the surface to be protected and then filled with high-strength mortar by injection. Variations of Fabriform and Fabricast consist of nylon bags similarly filled. Successful installations were reported by the manufacturer of Fabriform in Iowa, and North Dakota reported successful installations (see Design Guideline 9).

Soil Cement. In areas where any type of riprap is scarce, use of in-place soil combined with cement provides a practical alternative. The resulting mixture, soil cement, has been successfully used as bank protection in many areas of the Southwest (see Design Guideline 7). Unlike other types of bank revetment, where milder side slopes are desirable, soil cement in a stairstep construction can be used on steeper slopes (i.e., typically one to one), which reduces channel excavation costs. For many applications, soil cement is generally more aesthetically pleasing than other types of revetment.

8.6.3 Bulkheads

A bulkhead is a steep or vertical wall used to support a slope and/or protect it from erosion (See Section 8.4). Bulkheads usually project above ground, although the distinction between bulkheads and cutoff walls is not always sharp. Most bulkhead applications were found at abutments. They were found to be most useful at the following locations: (1) on braided streams with erodible sandy banks, (2) where banks or abutment fill slopes have failed by slumping, and (3) where stream alignment with the bridge opening was poor, to provide a transition between streambanks and the bridge opening. It was not clear what caused failures at five sites summarized in Brice and Blodgett (1978), but in each case, the probable cause was undermining.

8.6.4 Spurs

Spurs are permeable or impermeable structures which project from the bank into the channel. Spurs may be used to alter flow direction, induce deposition, or reduce flow velocity. A combination of these purposes is generally served. Where spurs project from embankments to decrease flow along the embankment, they are called embankment spurs. These may project into the floodplain rather than the channel, and thus function as spurs only during overbank flow. According to a summary prepared for the Transportation Research Board, spurs may protect a streambank at less cost than riprap revetment, and by deflecting current away from the bank and causing deposition, they may more effectively protect banks from erosion than revetment (Richardson and Simons 1984). Uses other than bank protection include the constriction of long reaches of wide, braided streams to establish a stable channel, constriction of short reaches to establish a desired flow path and to increase sediment transport capacity, and control of flow at a bend. Where used to constrict a braided stream to a narrow flow channel, the structure may be more correctly referred to as a dike or a retard in some locations (see Design Guideline 2).

Several factors enter into the performance of spurs, such as permeability, orientation, spacing, height, shape, length, construction materials, and the stream environment in which the spur is placed.

Impermeable Spurs. The case histories show good success with well-designed impermeable spurs at bends and at crossings of braided stream channels (eight sites). At one site, hardpoints barely projecting into the stream and spaced at about 100 to 150 ft (30 to 45 m) failed to stop bank erosion at a severe bend. At another site, spurs projecting 40 ft (12 m) into the channel, spaced at 100 ft (30 m), and constructed of rock with a maximum diameter of 1.5 ft (0.5 m) experienced erosion between spurs and erosion of the spurs. At a third site, spurs constructed of timber piling filled with rock were destroyed. Failure was attributed to the inability to get enough penetration in the sand-bed channel with timber piles and the unstable wide channel in which the thalweg wanders unpredictably. Spurs (or other countermeasures) are not likely to be effective over the long term in such an unstable channel unless well-designed, well-built, and deployed over a substantial reach of stream.

Although no failures from ice damage were cited for impermeable spurs, North Dakota uses steel sheet pile enclosed earth fill spurs because of the potential for ice damage. At one site, such a spur sustained only minor damage from 2.5 ft (0.75 m) of ice.

Permeable Spurs. A wide variety of permeable spur designs were also shown to successfully control bank erosion by the case histories. Failures were experienced at a site which is highly unstable with rapid lateral migration, abundant debris, and extreme scour depths. Bank revetments of riprap and car bodies and debris deflectors at bridge piers, as well as bridges, have also failed at this site. At another site, steel H-pile spurs with wire mesh have partially failed on a degrading stream.

8.6.5 Retardance Structures

A retardance structure (retard) can be a permeable or impermeable linear structure in a channel, parallel with and usually at the toe of the bank. The purposes of retardance structures are to reduce flow velocity, induce deposition, or to maintain an existing flow alignment. They may be constructed of earth, rock, timber pile, sheet pile, or steel pile. Steel jacks or tetrahedrons are also used (see Section 8.3).

Most retardance structures are permeable and most have good performance records. They have proved to be useful in the following situations: (1) for alignment problems very near a bridge or roadway embankment, particularly those involving rather sharp channel bends and direct impingement of flow against a bank (ten sites), and (2) for other bank erosion problems that occur very near a bridge, particularly on streams that have a wandering thalweg or very unstable banks (seven sites).

The case histories include a site where a rock retardance structure similar to a rock toe dike was successful in protecting a bank on a highly unstable channel where spurs had failed. There were, however, deficiencies in the design and construction of the spur installation. At another site, a rock retardance structure similar to a rock toe-dike has reversed bank erosion at a bend in a degrading stream. The USACE (1981) reported that longitudinal rock toe dikes were the most effective bank stabilization measure studied for channels having very dynamic and/or actively degrading beds.

8.6.6 Dikes

Dikes are impermeable linear structures for the control or containment of overbank flow (see Section 8.4). Most are in floodplains, but they may be within channels, as in braided streams or on alluvial fans. Dikes at study sites were used to prevent flood water from bypassing a bridge at four sites, or to confine channel width and maintain channel alignment at two sites. Performance of dikes at study sites was judged generally satisfactory.

8.6.7 Guide Banks

The major use of guide banks (formerly referred to as spur dikes) in the United States is to prevent erosion by eddy action at bridge abutments or piers where concentrated flood flow traveling along the upstream side of an approach embankment enters the main flow at the bridge (see Design Guideline 15). By establishing smooth parallel streamlines in the approaching flow, guide banks improve flow conditions in the bridge waterway. Scour, if it occurs, is near the upstream end of the guide bank away from the bridge. A guide bank differs from dikes described above in that a dike is intended to contain overbank flow while a guide bank only seeks to align overbank flow with flow through the bridge opening. An

extension of the usual concept of the purpose for guide banks, but not in conflict with that concept, is the use of guide banks and highway fill to constrict braided channels to one channel. At three sites studied, guide banks only or guide banks plus revetment on the highway fill were used to constrict wide braided channels rather severely, and the installations have performed well.

Guide bank performance was found to be generally satisfactory at all study sites. Performance is theoretically affected by construction materials, shape, orientation, and length.

Most guide banks are constructed of earth with revetment to inhibit erosion of the dike. At two sites, guide banks of concrete rubble masonry performed well. Riprap revetment is most common, but concrete revetment with rock riprap toe protection, rock-and-wire mattress, gabions, and grass sod have also performed satisfactorily. Since partial failure of a guide bank during a flood usually will not endanger the bridge, wider consideration should be given to the use of vegetative cover for protection. Partial failure of any countermeasure is usually of little significance so long as the purpose of protecting the highway stream crossing is accomplished.

Guide banks of elliptical shape, straight, and straight with curved ends performed satisfactorily at study sites, although there is evidence at one site that flow does not follow the nose of the straight guide bank. Clear evidence of the effect of guide bank orientation was not found at study sites although the conclusion from a study of guide banks in Mississippi that guide banks should be oriented with valley flow for skewed crossings of wooded floodplains was cited (Colson and Wilson 1973). There was evidence at one site that a guide bank may be severely tested where a large flow is diverted along the roadway embankment, as at a skewed crossing or on a wide floodplain which is severely constricted by the bridge. At these locations, embankment spurs may be advisable to protect the embankment from erosion and to reduce the potential for failure of the guide bank.

Guide banks at study sites tended to be longer than recommended by Bradley (1978) at most sites, except at five sites where they ranged from 16 to 75 ft (5 to 23 m). All guide banks appeared to perform satisfactorily. Not enough short guide banks were included in the study to reach conclusions regarding length.

8.6.8 Check Dams

Check dams are usually used to stop degradation in the channel in order to protect the substructure foundation of bridges (see Design Guideline 3). At one site, however, a check dam was apparently used to inhibit contraction scour in a bridge waterway. The problem with vertical scour was resolved, but lateral scour became a problem and riprap revetment on the streambanks failed (Brice and Blodgett 1978).

Scour downstream of check dams was found to be a problem at two sites, especially lateral erosion of the channel banks. Riprap placed on the streambanks at the scour holes also failed, at least in part because of the steep slopes on which the riprap was placed. At the time of the study, lateral erosion threatened damage to bridge abutments and highway fills. At another site, a check dam placed at the mouth of a tributary stream failed to stop degradation in the tributary and the delivery of damaging volumes of sediment to the main stream just upstream of a bridge.

No structural failure of check dams was documented. Failures are known to have occurred, however, and the absence of documented failures in this study should not be given undue weight. Failure can occur by bank erosion around the ends of the structure resulting in

outflanking; by seepage or piping under or around the structure resulting in undermining and structural or functional failure; by overturning, especially after degradation of the channel downstream of the structure; by bending of sheet pile; by erosion and abrasion of wire fabric in gabions or rock-and-wire mattress; or by any number of structural causes for failure.

8.6.9 Jack or Tetrahedron Fields

Jacks and tetrahedrons function as flow control measures by reducing the water velocity along a bank, which in turn results in an accumulation of sediment and the establishment of vegetation. Steel jacks, or Kellner jacks which consist of six mutually perpendicular arms rigidly fixed at the midpoints and strung with wire are the most commonly used (see Section 8.3). Tetrahedrons apparently are not currently used by DOTs. Jacks are usually deployed in fields consisting of rows of jacks tied together with cables.

Four sites where steel jack fields were used are included in the case histories. At two sites, the jack fields performed satisfactorily. Jacks were buried in the streambed and rendered ineffective at one site, and jacks were damaged by ice at one site, but apparently continued to perform satisfactorily. From Keeley's (1971) observations of the performance of jack fields used in Oklahoma and findings of the study of countermeasures by Brice and Blodgett (1978), the following conclusions were reached regarding performance:

- The probability of satisfactory performance of jack fields is greatly enhanced if the stream transports small floating debris and sediment load in sufficient quantity to form accumulations during the first few years after construction.
- Jack fields may serve to protect an existing bank line, or to alter the course of a stream if the stream course is realigned and the former channel backfilled before the jack field is installed.
- On wide shallow channels, which are commonly braided, jack fields may serve to shift the bank line channelward if jacks of large dimensions are used.

8.6.10 Special Devices for Protection of Piers

Countermeasures at piers have been used to combat abrasion of piers, to deflect debris, to reduce local scour, and to restore structural integrity threatened by scour. Retrofit countermeasures installed after problems develop are common. The usual countermeasure against abrasion consists of steel armor on the upstream face of a pier in the area affected by bed load. At one site, a pointed, sloping nose on a massive pier, called a special "cutwater" design, and a concrete fender debris deflector has functioned to prevent debris accumulation at the pier. At another site, a steel rail debris deflector worked until channel degradation caused all countermeasures to fail.

Countermeasures used to restore structural integrity of bridge foundations included in the case histories include underpinning, sheet pile driven around the pier, and a grout curtain around the pier foundation.

8.6.11 Channel Alterations

Although channel alterations or modifications have been curtailed due to environmental concerns, their judicious use can be a viable countermeasure not to be dismissed. It is recognized that extensive channelization projects, usually made to reduce floodplain damage, have resulted in serious channel degradation and lateral erosion. However, there is little documentation of upstream or downstream environmental damage of an alteration of a short reach in the vicinity of a bridge (Brice and Blodgett 1978).

In a United States Geological Survey study for FHWA of 103 stream channels that were altered for purpose of bridge construction mostly during the period of 1960-1970, the stability of the relocated channel was rated as good at 36 sites, as fair to good at 42 sites, as fair at 15 sites, and as poor at 7 sites. In comparison with bank stability of the channels where such data was available before and after relocation, bank stability was about the same at 45 sites, better at 28 sites, and worse at 14 sites. At sites where the value of channel relocation length to channel width was below 100, the effects of length of channel relocation were dominated by other factors (Brice 1981) (see Section 8.5).

8.6.12 Modification of Bridge Length and Relief Structures

A countermeasure for contraction scour and lateral movement of stream banks that may not always be considered for an existing bridge but may be needed is to increase its length. Increased bridge length was used at 11 sites and increased freeboard was provided at 2 sites. Other techniques that have been used by State DOTs include the design of abutments as piers so that the bridge may be extended to accommodate future movement of the stream. Other means of providing additional relief to flow would be the use of a relief bridge.

8.6.13 Investment in Countermeasures

While it may be possible to predict that bank erosion will occur at or near a given location in an alluvial stream, one can frequently be in error about the location or magnitude of potential erosion. At some locations, unexpected lateral erosion occurs because of a large flood, a shifting thalweg, or from other actions of the stream or activities of man. Therefore, where the investment in a highway crossing is not in imminent danger of being lost, it is often prudent to delay the installation of countermeasures until the magnitude and location of the problem becomes obvious. In many, if not most, of the case histories collected by Brice et al., DOTs invested in countermeasures after a problem developed rather than in anticipation of a problem (Brice and Blodgett 1978, Brice 1984).

CHAPTER 9

SCOUR MONITORING AND INSTRUMENTATION

9.1 INTRODUCTION

There are many scour critical bridges on spread footings or shallow piles in the United States and a large number of bridges with unknown foundation conditions (Lagasse et al. 1995). With limited funds available, these bridges cannot all be replaced or repaired. Therefore, they must be monitored and inspected following high flows. During a flood, scour is generally not visible and during the falling stage of a flood, scour holes generally fill in. Visual monitoring during a flood and inspection after a flood cannot fully determine that a bridge is safe. Instruments to measure or monitor maximum scour would resolve this uncertainty. As introduced in Chapter 2 (Section 2.3), monitoring as a countermeasure for a scour critical bridge involves two basic categories of instruments: portable instruments and fixed instruments.

Whether to use fixed or portable instruments in a scour monitoring program depends on many different factors. Unfortunately, there is not one type of instrument that works in every situation encountered in the field. Each instrument has advantages and limitations that influence when and where they should be used. The idea of a toolbox, with various instruments that can be used under specific conditions, best illustrates the strategy to use when trying to select instrumentation for a scour monitoring program. Specific factors to consider include the frequency of data collection desired, the physical conditions at the bridge and stream channel, and traffic safety issues.

Fixed instrumentation is used when frequent measurements or regular, ongoing monitoring (e.g., weekly, daily, or continuous) are required. Portable instruments would be preferred when only occasional measurements are required, such as after a major flood, or when many different bridges must be monitored on a relatively infrequent basis. The physical conditions at the bridge, such as height off the water and type of superstructure, can influence the decision to use fixed or portable equipment. For example, bridges that are very high off the water, or that have large deck overhang or projecting geometries, would complicate portable measurements from the bridge deck. Making portable measurements from a boat assumes that a boat ramp is located near the bridge, and/or there are no issues with limited clearance under the bridge that would prohibit safe passage of a boat. Bridges with large spread footings or pile caps, or those in very deep water can complicate the installation of some types of fixed instruments. Stream channel characteristics include sediment and debris loading, air entrainment, ice accumulation, or high velocity flow, all of which can adversely influence various measurement sensors used in fixed or portable instruments. Traffic safety issues include the need for traffic control or lane closures when either installing or servicing fixed instruments, or attempting to make a portable measurement from the bridge deck.

It is apparent that the selection of the instrument category (fixed or portable) and the specific instrument types to be used in a monitoring plan is not always straightforward. In some situations there is no clearly definable plan that will be successful, and the monitoring plan is developed knowing that the equipment may not always work as well as might be desired. Ultimately, the selection of any type of instrumentation must be based on a clear understanding of its advantages and limitations, and in consideration of the conditions that exist at the bridge and in the channel.

To improve the state-of-practice when adopting fixed instrumentation as a countermeasure, the Transportation Research Board (TRB) under the National Cooperative Highway Research Program (NCHRP) completed NCHRP Project 21-3 "Instrumentation for Measuring Scour at Bridge Piers and Abutments" in 1997 (Lagasse et al. 1997, Schall et al. 1997a, 1997b). NCHRP Project 21-7, "Portable Scour Monitoring Equipment," was completed in 2004 and developed an articulated arm truck as a platform for deploying a variety of portable scour monitoring instruments (Schall and Price 2004). In addition, to facilitate the technology transfer of instrumentation-related research to the highway industry, particularly those in inspection and maintenance operations, the Federal Highway Administration (FHWA) developed a Demonstration Project (DP97) on scour monitoring and instrumentation. The purpose of Demonstration Project 97 was to promote the use of new and innovative equipment, both fixed and portable, to measure scour, monitor changes in scour over time, detect the extent of past scour, and serve as countermeasures (FHWA 1998, Ginsberg and Schall 1998). This chapter provides information on the use of portable and fixed instrumentation for scour monitoring. The portable instrument discussion includes lessons learned from NCHRP 21-7 and concepts developed during DP97. The fixed instrument discussion includes results from NCHRP Project 21-3 and highlights fixed instrument installations completed in the last ten years. Information on implementation and experience of several State DOTs with scour monitoring instrumentation is also summarized.

9.2 PORTABLE INSTRUMENTATION

9.2.1 Components of a Portable Instrument System

Portable instrumentation is typically used when a fixed instrument has not been installed at a bridge; however, portable instruments are also useful when it is necessary to supplement fixed instrument data at other locations along the bridge. Physical probing has been used for many years as the primary method for portable scour monitoring by many DOTs. More recently, sonar has seen increased use, in part due to the technology transfer provided through FHWA's Demonstration Project 97 (FHWA 1998). The use of these methods during low-flow conditions has been very successful, for example during the 2-year inspection cycle; however, their success during flood conditions, when the worst scour often occurs, has been more limited. When appropriate, portable instrumentation is an important part of a scour monitoring program.

A portable scour measuring system typically includes four components (Mueller and Landers 1999):

1. Instrument for making the measurement
2. System for deploying the instrument(s)
3. Method to identify and record the horizontal position of the measurement
4. Data-storage device

9.2.2 Instrument for Making the Measurement

A wide variety of instruments have been used for making portable scour measurements. In general, the methods for making a portable scour measurement can be classified as:

1. Physical probing
2. Sonar
3. Geophysical

Physical Probes. Physical probes refer to any type of device that extends the reach of the inspector, the most common being sounding poles and sounding weights. Sounding poles are long poles used to probe the bottom (Figure 9.1). Sounding weights, sometimes referred to as lead lines, are typically a torpedo shaped weight suspended by a measurement cable (Figure 9.2). This category of device can be used from the bridge or from a boat. An engineer diver with a probe bar is another example of physical probing. Physical probes only collect discrete data (not a continuous profile), and can be limited by large depth and velocity (e.g., during flood flow condition) or debris and/or ice accumulation. Advantages of physical probing include not being affected by air entrainment or high sediment loads, and it can be effective in fast, shallow water.

Sonar. Sonar instruments (also called echo sounders, fathometers or acoustic depth sounders) measure the elapsed time that an acoustic pulse takes to travel from a generating transducer to the channel bottom and back (FHWA 1998). Sonar is an acronym for SOund NAvigation and Ranging that was developed largely during World War II. However, early sonar systems were used during World War I to find both submarines and icebergs and called ASDICs (named for the Antisubmarine Detection Investigation Committee). As technology has improved in recent years better methods of transmitting and receiving sonar and processing the signal have developed, including the use of digital signal processing (DSP). The issues of transducer frequency (typically around 200 kHz) and beam width are important considerations in the use of sonar for scour monitoring work. Additionally, sonar may be adversely impacted by high sediment loads or air entrainment.

Applications of single beam sonar range from fish finders to precision survey-grade hydrographic survey fathometers. Low-cost fish-finder type sonar instruments have been widely used for bridge scour investigations (Figure 9.3) with a tethered float to deploy the transducer. Float platforms have included kneeboards (Figure 9.4) and pontoon-style floats (Figure 9.5).

Other types of sonar, such as side scan, multi-beam and scanning sonar, are specialized applications of basic sonar theory. These devices are commonly used for oceanographic and hydrographic survey work, but have not been widely utilized for portable scour monitoring. Side scan sonar transmits a specially shaped acoustic beam to either side of the support craft. These applications often deploy the transducer in a towfish, normally positioned behind and below the surface vessel.

While side scan sonar is one of the most accurate systems for imaging large areas of channel bottom, most side scan systems do not provide depth information. Multi-beam systems provide a fan-shaped coverage similar to side scan, but output depths rather than images. Additionally, multi-beam systems are typically attached to the surface vessel, rather than being towed. Scanning sonar works by rotation of the transducer assembly or sonar "head," emitting a beam while the head moves in an arc. Since the scanning is accomplished by moving the transducer, rather than towing, it can be used from a fixed, stationary position. Scanning sonar is often used as a forward looking sonar for navigation, collision avoidance and target delineation.

The Sonar Scour Vision system was developed by American Inland Divers, Inc (AIDI) using a rotating and sweeping 675 Khz high resolution sonar (Barksdale 1994). The transducer is mounted in a relatively large hydrodynamic submersible, or fish, that creates a downward force adequate to submerge the transducer in velocities exceeding 20 ft/s (6 m/s) (Figure 9.6). Given the forces created, the fish must be suspended from a crane or boom truck on the bridge. From a single point of survey, the system can survey up to 328 ft (100 m) radially. Data collected along the face of the bridge can be merged into a real-time 3-dimensional image with a range of 295 ft (90 m) both upstream and downstream of the bridge.



Figure 9.1 Sounding pole measurement.



Figure 9.2. Lead-line sounding weight.



Figure 9.3. Portable sonar in use.



Figure 9.4. Kneeboard float.



Figure 9.5. Pontoon float.



Figure 9.6. AIDI system (Barksdale 1994).

Geophysical. Surface geophysical instruments are based on wave propagation and reflection measurements. A signal transmitted into the water is reflected back by interfaces between materials with different physical properties. A primary difference between sonar and geophysical techniques is that geophysical methods provide sub-bottom, while sonar can only "see" the water-soil interface and is not able to penetrate the sediment layer. The main difference between different geophysical techniques are the types of signals transmitted and the physical property changes that cause reflections. A seismic instrument uses acoustic signals, similar to sonar, but at a lower frequency (typically 2-16 kHz). Like sonar, seismic signals can be scattered by air bubbles and high sediment concentrations. A ground penetrating radar (GPR) instrument uses electromagnetic signals (typically 60-300 mHz), and reflections are caused by interfaces between materials with different electrical properties. In general, GPR will penetrate resistive materials and not conductive materials. Therefore, it does not work well in dense, moist clays, or saltwater conditions.

The best application of geophysical technology in scour monitoring may be as a forensic evaluation tool, used after the flood during lower flow conditions to locate scour holes and areas of infilling. In general, the cost and complexity of the equipment and interpretation of the data are limiting factors for widespread use and application as a portable scour monitoring device. These issues have moderated as newer, lower cost GPR devices with computerized data processing capabilities have been developed. However, GPR may still be limited by cost and complexity, and often the need for bore hole data and accurate bridge plan information to properly calibrate and interpret the results.

9.2.3 System for Deploying the Instrument

The system for deploying the scour instrument is a critical component in a successful portable scour measurement system. In practical application, particularly under flood flow conditions, the inability to properly position the instrument is often the limiting factor in making a good measurement. The use of different measurement technologies from different deployment platforms can produce a wide variety of alternative measurement approaches.

Deployment methods for portable instruments can be divided into two primary categories:

1. From the bridge deck
2. From the water surface

Bridge Deck Deployment. Bridge deck deployment can be defined by two categories, non-floating and floating. Non-floating systems generally involved standard stream gaging equipment and procedures, including the use of various equipment cranes and sounding weights for positioning a sensor in the water. This category could also include devices that use a probe or arm with the scour measurement device attached to the end. Probes or arms include things as simple as an extendable pole or rod (such as a painter's pole), to a remotely controlled articulated arm. Hand held probes or arms are not generally useable at flood flow conditions.

A prototype articulated arm to position a sonar transducer was developed under an FHWA research project (Bath 1999). An onboard computer calculated the position of the transducer based on the angle of the boom and the distance between the boom pivot and transducer. Additionally, the system could calculate the position of the boom pivot relative to a known position on the bridge deck. The system was mounted on a trailer for transport and could be used on bridge decks from 16 - 50 ft (5 - 15 m) above the water surface (Figure 9.7). Field testing during the 1994 floods in Georgia indicated that a truck mounted system would provide better maneuverability, and that a submersible head or the ability to raise the boom pivot was necessary to allow data collection at bridges with low clearance (less than 16 ft (5 m)).



Figure 9.7. FHWA articulated arm in use.

NCHRP Project 21-7 (Schall and Price 2004) resulted in a truck mounted articulated arm to facilitate portable scour measurements during flood conditions (Figure 9.8). The truck was designed to operate in high velocity flow while providing accurate positioning information and efficient data collection procedures. These measurements can be completed from a variety of bridge geometries including limited clearance, overhanging geometry, and high bridges. Scour measurement can be by a streamlined sonar probe, sounding weights, kneeboards, or physical probing. A dual winch system was developed to facilitate cable suspended operations. Crane location is tracked by a variety of sensors installed on the articulated arm, and by a survey wheel on the back of the truck. Data loggers manage data, and a laptop is used for data reduction. Sonar data and positioning data collected at the end of the crane are transmitted by a wireless link that eliminates any wires from the water surface to the truck (Figure 9.9).

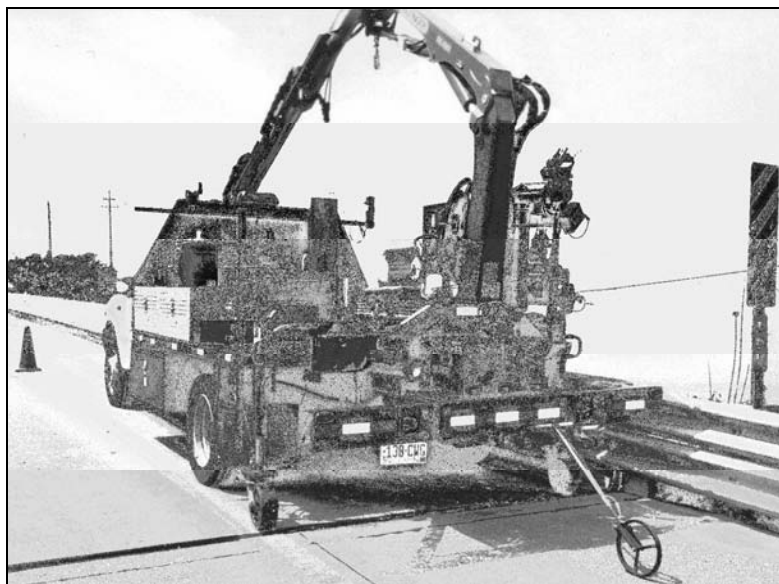

Figure 9.8. NCHRP 21-3 articulated arm truck (Schall and Price 2004).



Figure 9.9. Sonar instrument deployed from articulated arm truck.

Float based systems permit measurement beneath the bridge and along side the bridge piers. Tethered floats are a low-cost approach that have been used with some success during flood flow conditions. A variety of float designs have been proposed and used to varying degrees for scour measurements, typically to deploy a sonar transducer. Common designs include foam boards, PVC pontoon configurations, spherical floats, water skis and kneeboards (FHWA 1998). The size of the float is important to stability in fast moving, turbulent water.

Floating or non-floating systems can be also be deployed from a bridge inspection truck, an approach that is particularly useful when the bridge is high off the water. For example, bridges that are greater than 50 ft (15 m) off the water are typically not accessible from the bridge deck without using this approach.

Water Surface Deployment. Water surface deployment typically involves a manned boat, however, safety issues under flood conditions have suggested the use of unmanned vessels. The use of manned boats generally requires adequate clearance under the bridge and nearby launch facilities. This can be a problem at flood conditions when the river stage may approach or submerge the bridge low chord, and/or boat ramps may be underwater. Smaller boats may be easier to launch, but safety at high flow conditions may dictate use of a larger boat, further complicating these problems.

When clearance is not an issue, the current and turbulence in the bridge opening may be avoided using one of the tethered floating or nonfloating methods described above from a boat positioned upstream of the bridge. For example, a pontoon or kneeboard float with a sonar transducer could be maneuvered into position from a boat holding position upstream of the bridge, thereby avoiding the current and turbulence problems at the bridge itself.

The safety, launching and clearance issues have suggested that an unmanned or remote control boat might be a viable alternative. A prototype unmanned boat using a small flat bottom jon boat and an 8 hp outboard motor with remote controls (Figure 9.10) was successfully tested during six flood events (Mueller and Landers 1999).



Figure 9.10. Unmanned, remote control boat.

9.2.4 Positioning Information

In order to evaluate the potential risk associated with a measured scour depth it is necessary to know the location of the measurement, particularly relative to the bridge foundation. Location measurements can range from approximate methods, such as "3 ft (1 m) upstream of pier 3," to precise locations based on standard land and hydrographic surveying technology.

The most significant advancement for portable scour measurement positioning may be in the use of Global Positioning Systems (GPS). GPS is a positioning system based on a constellation of satellites orbiting the earth. An advantage of GPS over traditional land-based surveying techniques is that line-of-sight between control points is not necessary. A GPS survey can be completed between control points without having to traverse or even see the other point. GPS also works at night and during inclement weather, which could be a real advantage for scour monitoring during flood conditions. The most significant disadvantage of GPS is the inability to get a measurement in locations where overhead obstructions exist, such as tree canopy or bridge decks. However, GPS measurements up to the bridge face, without venturing under the bridge, have been successful.

9.2.5 Data Storage Devices

Portable scour monitoring data are typically manually recorded in a field book, however, there has been a growing interest in more automated data collection using various data storage devices. Available data storage devices include hydrometeorological data loggers, laptop computers and more recently palm computers and organizers. Data loggers provide a compact storage device, however, they are generally not very user friendly with each company typically having a unique programming language and approach. In field applications, laptop computers are bulky and need to be ruggedized to survive the rain, dirt and dust of a field environment. Palm computers and organizers may have an application as their capability and user-friendliness continue to improve. The advantage of laptop computers and palm computers is the ability to integrate data reduction software, such as plotting or topographic mapping programs to display the results, often in real time mode while the data collection occurs.

9.3 FIXED INSTRUMENTATION

9.3.1 NCHRP Project 21-3

The basic objective of NCHRP Project 21-3 was to develop, test, and evaluate fixed instrumentation that would be both technically and economically feasible for use in measuring or monitoring maximum scour depth at bridge piers and abutments (Lagasse et al. 1997). The scour measuring or monitoring device(s) were required to meet the following mandatory criteria.

Mandatory Criteria

- Capability for installation on or near a bridge pier or abutment
- Ability to measure maximum scour depth within an accuracy of ± 1 ft (± 0.3 m)
- Ability to obtain scour depth readings from above the water or from a remote site
- Operable during storm and flood conditions

Where possible, the devices should meet the following desirable criteria:

Desirable Criteria

- Capability to be installed on most existing bridges or during construction of new bridges
- Capability to operate in a range of flow conditions
- Capability to withstand ice and debris
- Relatively low cost
- Vandal resistant
- Operable and maintainable by highway maintenance personnel

Since the mandatory criteria required that the instruments be capable of installation on or near a bridge pier or abutment, the research was limited to fixed instruments only. While the research was conducted in phases, a final project report was prepared to integrate and summarize the findings, interpretation, conclusions and recommendations for the total research effort (Lagasse et al. 1997). A separate Installation, Operation, and Fabrication Manual was developed for both the magnetic sliding collar device and low-cost sonic instrument system that resulted from this research (Schall et al. 1997a, 1997b).

9.3.2 Scour Measurement

Although a vast literature exists relating to bridge scour, relatively few reports deal specifically with instrumentation. The final report for NCHRP Project 21-3 includes an extensive bibliography on equipment for scour measurement and monitoring (Lagasse et al. 1997). A detailed survey of the evolution of scour measuring instrumentation was presented at the Transportation Research Board Third Bridge Engineering Conference in 1991 (Lagasse et al. 1991). This section summarizes the development of scour measuring equipment and techniques that had particular relevance to the instrumentation developed under the NCHRP project.

Major advances in instrumentation such as sonar, sonic sounders, electronic positioning equipment, and radar occurred during World War II. By the mid 1950s, many devices became commercially available and were introduced into scientific studies of rivers. A dual channel sonic stream monitor was used in the 1960s to study alluvial channel bed configurations and the scour and fill associated with migrating sand waves. Commercial sonic sounders became available about the same time and soon were used extensively in hydrographic surveys.

In the 1970s, many scour studies were undertaken in New Zealand. One of the instruments used in the field to measure maximum scour depth at bridge piers was called the "Scubamouse." The device consists of a vertical pipe buried or driven into the streambed in front of the bridge pier around which is placed a horseshoe-shaped collar that initially rests on the streambed. The collar slides down the pipe and sinks to the bottom of the scour hole as scour progresses during a flood. The position of the collar is determined by sending a detector down the inside of the pipe after the flood. Earlier models involved a metal detector inside a PVC pipe, but the pipe was sometimes damaged by debris, so the current models use a steel pipe, a radioactive collar, and a radiation detector inside the pipe. This device has been installed on many bridges in New Zealand (Melville et al. 1989).

In the United Kingdom, Hydraulic Research Limited of Wallingford has developed and deployed a buried rod instrument system to monitor bed scour during flood events (Waters 1994). This 'Tell Tail' scour monitoring system is based on omni-directional motion sensors, buried in the river or sea bed adjacent to the structure. The sensors are mounted on flexible 'tails' and are connected to the water surface via protected cables. Under normal flow conditions, the detectors remain buried and do not move. When a scour hole develops, the sensors are exposed and transmit alarm signals to the surface.

In the early 1990s, there were no accepted methods or off-the-shelf equipment for collecting scour data in the United States. In part, this was because there had been no coordinated long-term effort to study scour processes. Also, most scour studies were site-specific and the equipment and techniques that were used were tailored to the geometry of the site and its hydrology and hydraulic conditions. The Brisco Monitor™, a sounding rod device, was available, but had not been tested extensively in the field.

Scour studies in the United States were carried out with a great variety of portable equipment and techniques, and, through the U.S. Geological Survey (USGS) National Scour Study, conducted in cooperation with the Federal Highway Administration (FHWA), efforts were made to standardize the collection of scour data (Landers and Trent 1991). Techniques for determining the extent of local scour include the use of divers and visual inspection, direct measures of scour with mechanical and electronic devices, and indirect observations using ground-penetrating radar and other geophysical techniques (Gorin and Haeni 1989).

In the early 1990s, the USGS investigated the use of fixed instruments for scour measurement at a new bridge on U.S. Highway 101 across Alsea Bay near Walport, Oregon. Depth soundings were made using commercially available sonic sounders. The transducers for sounding were mounted on brackets attached to the piers and pointed out slightly to avoid interference from the side of the pier. The system worked well, but the installation was not subject to debris, ice, or air entrainment from highly turbulent flows (Crumrine et al. 1996).

The initial literature search on scour instrumentation in 1990 revealed, and a resurvey of technology in 1994 confirmed, that fixed scour-measuring and -monitoring instruments can be grouped into four broad categories:

1. Sounding rods - manual or mechanical device (rod) to probe streambed
2. Buried or driven rods - device with sensors on a vertical support, placed or driven into streambed
3. Fathometers - commercially available sonic depth finder
4. Other Buried Devices - active or inert buried sensor (e.g., buried transmitter)

As a result of the literature review a laboratory testing program was designed to test at least one device from each category and to select devices for field testing that would have the greatest potential for meeting mandatory and desirable criteria.

9.3.3 Summary of NCHRP Project 21-3 Results

No single methodology or instrument can be utilized to solve the scour monitoring problems for all situations encountered in the field. Considering the wide range of operating conditions necessary, environmental hazards such as debris and ice, and the variety of stream types and bridge geometries encountered in the field, it is obvious that several instrument systems using different approaches to detecting scour will be required.

Under NCHRP Project 21-3, a variety of scour measuring and monitoring methods were tested in the laboratory and in the field, including sounding rods, driven rod devices, fathometers, and buried devices. Two instrument systems, a low-cost bridge deck (above water) serviceable fathometer and a magnetic sliding collar device using a driven rod approach were installed under a wide range of bridge substructure geometry, flow, and geomorphic conditions. Both instrument systems met all of the mandatory criteria and most of the desirable criteria established for the project and were considered fully field deployable in 1997.

The Installation, Operation, Fabrication Manuals for the low-cost sonic system and magnetic sliding collar devices (Schall et al. 1997a, 1997b) provide complete instrument documentation, including specifications and assembly drawings. That information, together with the findings, appraisal, and applications information of the final report (Lagasse et al. 1997), provide a potential user of a scour monitoring device complete guidance on selection, installation, operation, maintenance, and if desired, fabrication of two effective systems, one of which could meet the need for a fixed scour instrument at most sites in the field.

Of the devices tested extensively in the field, the low-cost sonic system and the manual-readout sliding collar device are both vulnerable to ice and debris; however, both proved to be surprisingly resistant to damage from debris or ice impact at field test sites. The sonic system can be rendered inoperative by the accumulation of debris, and presumably ice, between the transducer face and streambed. The manual-readout sliding collar requires an extension conduit, generally up the front face of a pier, which can be susceptible to debris or ice impact damage unless the extension can be firmly anchored to a substructure element.

From this perspective, the automated sliding collar device has the distinct advantage of having a configuration which places most of the device below the streambed, and therefore, less vulnerable to ice or debris. The connecting cable from the device to a data logger on the bridge deck can be routed through a buried conduit and up the downstream face of a bridge pier or abutment where it is much less vulnerable to damage. An overview of these and other operational instrument systems is provided in the next section.

9.3.4 Operational Fixed Instrument Systems

A scour monitoring system at a bridge may be comprised of one or more types of fixed instruments. The various devices are either mounted on the bridge or installed in the streambed in the vicinity of the bridge. Remote units with data loggers may be installed so that the scour measuring device transmits data to the unit. The data from any of these fixed instruments may be downloaded manually at the site, or it can be telemetered to another location. The early scour monitoring devices measured streambed elevations using simple on-site manually read units. The more recent installations use remote technology for data retrieval. Each bridge may have one or more remote sensor units that transmit data to a master unit on or near the bridge (Figure 9.11). The scour monitoring data is then transmitted from the master unit to a central office for data analysis. Remote technology transmits data by modem using cellular or landline telephones, or by satellite. Recent installations include systems that post the data on the Internet so that authorized persons may access the data from any location using a computer with Internet access.

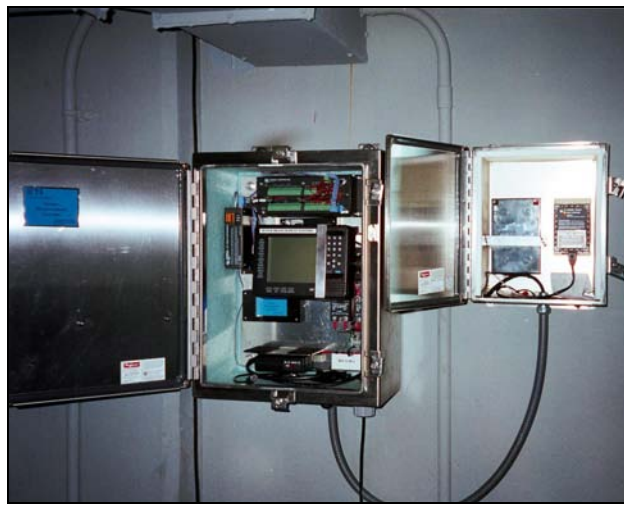

Figure 9.11. Master station with data logger for use with any of the fixed instruments.

Sonars. The sonar scour monitors are mounted onto the pier or abutment face (Figures 9.12 and 13) to take streambed measurements. Currently new sonar monitors range from fish finders to smart sonar transducers, both of which are commercially available. The sonar transducer is connected to the sonar instrument or directly to a data logger. The sonar instrument measures distance based on the travel time of a sound wave through water to the stream bed and back to the transducer. The data logger controls the sonar system operation and data collection functions and can be programmed to take measurements at prescribed intervals. Sonar sensors normally take a rapid series of measurements and use an averaging scheme to determine the distance from the sonar transducer to the streambed. These instruments can track both the scour and refill (deposition) processes. The early sonar monitors used off-the-shelf "fish finders."

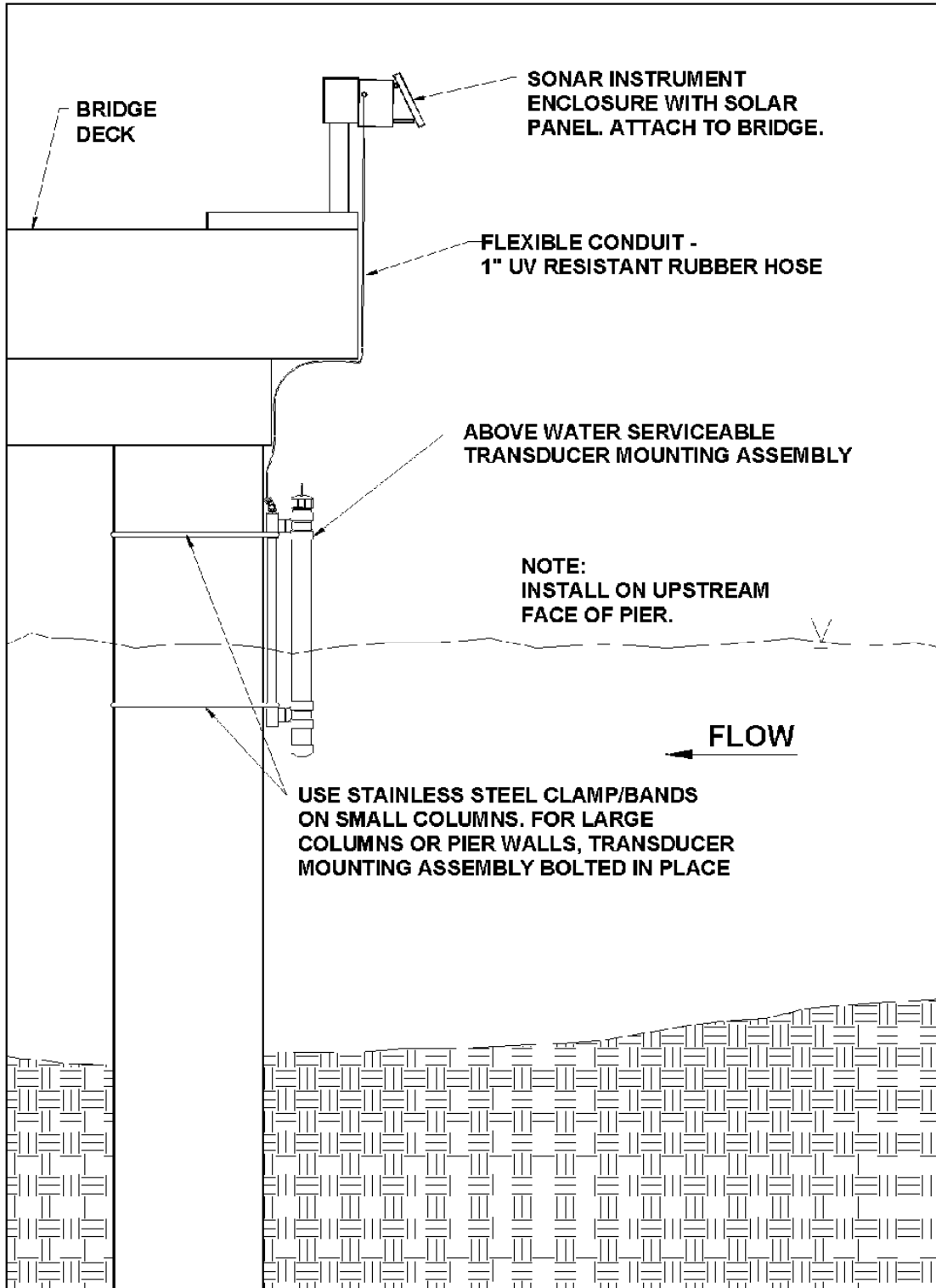

Figure 9.12. Above-water serviceable low-cost fathometer system (Schall et al. 1997b).



Figure 9.13. Sonar scour monitor installation including remote station and solar panel.

Magnetic Sliding Collars. Magnetic sliding collars (Figures 9.14, 9.15, and 9.16) are rods or masts that are attached to the face of a pier or abutment and driven or augered into the streambed. A collar with magnetic elements is placed on the streambed around the rod. If the streambed erodes, the collar moves or slides down the rod into the scour hole. The depth of the collar provides information on the scour that has occurred at that particular location.

The early version of the sliding magnetic collar used a battery operated manual probe that was inserted down from the top and a buzzer sounded when the probe tip sensed the level of the magnetics on the collar (Figure 9.14). More recent instruments have a series of magnetically activated switches inserted in the rod at known distances. Magnets on the steel collar come into proximity with the switches as the collar slides into the scour hole. The switches close sequentially as the collar slides by, and their position is sensed by the electronics (Figures 9.15 and 9.16). A data logger reads the level of the collar via the auto probe and tracks scour activity. Sonar scour monitors may be used to provide the infill scour process at a bridge, whereas magnetic sliding collars can only be used to monitor the maximum scour depth.

Float-out Devices. Buried devices may be active or inert buried sensors or transmitters. Float-out devices (Figure 9.17) are buried transmitters. This device consists of a radio transmitter buried in the channel bed at pre-determined depth(s). If the scour reaches that particular depth, the float-out device floats to the stream surface and an onboard transmitter is activated. It transmits the float-out device's digital identification number with a radio signal. The signal is detected by a receiver in an instrument shelter on or near the bridge. The receiver listens continuously for signals emitted by an activated float-out device. A decoded interface decodes the activated float-out device's unique digital identification number that will determine where the scour has occurred. A data logger controls and logs all activity of the scour monitor. These devices are particularly easy to install in dry riverbeds, during the installation of an armoring countermeasure such as riprap, and during the construction of a new bridge. The float-out sensor is a small low-powered digital electronics position sensor and transmitter. The electronics draws zero current from a lithium battery which provides a 9-year life expectancy when in the inactive state buried in the streambed.

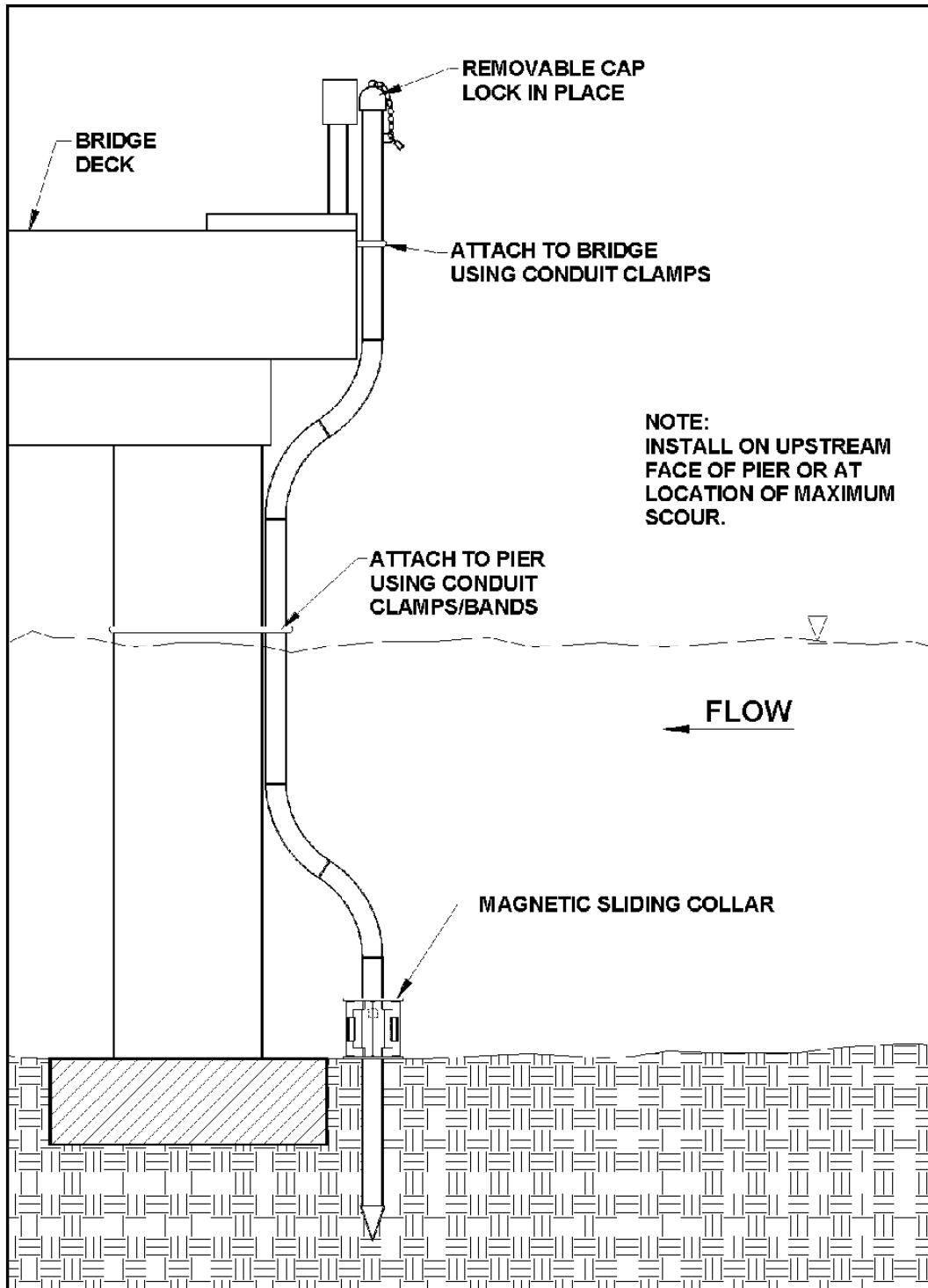

Figure 9.14. Manual read out magnetic sliding collar device (Schall et al. 1997a).

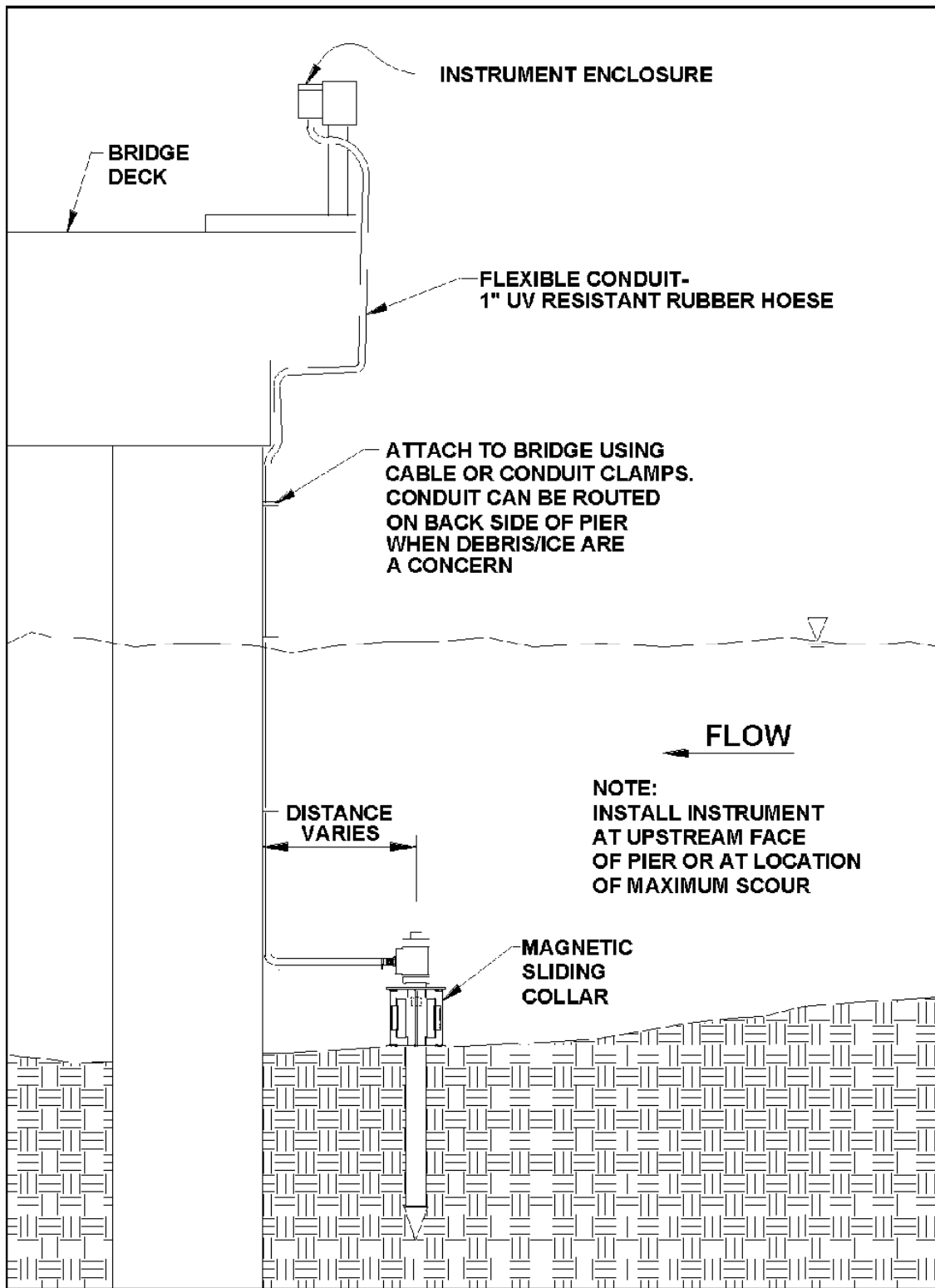

Figure 9.15. Automated read out magnetic sliding collar system (Schall et al. 1997a).



Figure 9.16. Detail of magnetic sliding collar on the streambed.



Figure 9.17. Float-out devices prior to installation. Color coded and numbered for identification purposes.

Tilt Sensors. Tilt sensors (Figure 9.18) measure movements and rotations of the bridge itself. An X, Y tilt sensor or clinometer monitors the bridge position. Should the bridge be subject to scour causing one of the support piers or abutments to settle, one of the tilt sensors would detect the change. A pair of clinometers is installed on the bridge piers or abutments (Figure 9.19). One tilt meter senses rotation parallel to the direction of traffic (the longitudinal direction of the bridge), while the other senses rotation perpendicular to traffic (usually parallel with the stream flow).



Figure 9.18. Tilt meter on California bridge.



Figure 9.19. Detail of tilt meter.

Time Domain Reflectometers. In Time Domain Reflectometry (TDR) an electromagnetic pulse is sent down two parallel pipes that are buried vertically in the streambed (Figure 9.20) (Zabilansky 2002). When the pulse encounters a change in the boundary conditions (i.e., the soil-water interface), a portion of the pulse's energy is reflected back to the source from the boundary. The remainder of the pulse's energy propagates through the boundary until another boundary condition (or the end of the probe) causes part or all of the energy to be reflected back to the source. By monitoring the round-trip travel time of a pulse in real time, the distance to the respective boundaries can be calculated and this provides information on any changes in streambed elevation. Monitoring travel time in real time allows the processes affecting sediment transport to be correlated with the change in bed elevation. Using this procedure, the effects of hydraulic and ice conditions on the erosion of the riverbed can be documented.

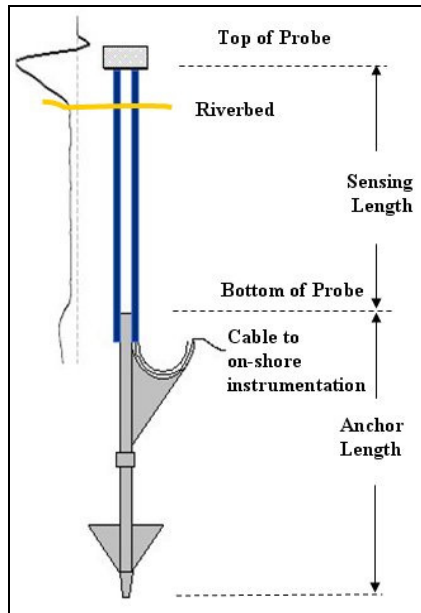

Figure 9.20. Time domain reflectometry probe.
(Courtesy of USACE Cold Regions Research and Engineering Laboratory)

Sounding Rods. Sounding-rod or falling-rod instruments are manual or mechanical (automated) gravity based physical probes (Figure 9.21). As the streambed scours, the rod, with its foot resting on the streambed, drops following the streambed and causing the system counter to record the change. The foot must be of sufficient size to prevent penetration into the streambed caused by the weight of the rod and the vibration of the rod from flowing water. These devices are susceptible to streambed surface penetration in sand bed channels and this influences their accuracy. Consequently, they are best suited to monitoring coarse bed streams or riprap stability (as shown in Figure 9.21)



Figure 9.21. Brisco Monitor sounding rods installed at a bridge pier in New York to monitor movement of riprap (Butch 1996).

Summary. If recording a series of streambed elevations over time is of interest, sonars, magnetic sliding collars and sounding rod monitors may be used (only the sonar will record scour and fill). If a bridge owner is interested only in when a certain streambed elevation is reached, float-outs may be employed. For specific information on a pier or abutment, tilt sensors record relative rotation and movement of the structure. Additional fixed instruments may be added to the scour monitoring system to gather information on water elevations, water velocities and/or temperature readings.

Data from any of these fixed instruments may be downloaded manually at the site, or may be telemetered to another location. A scour monitoring system at a bridge may use one of these devices, or include a combination of two or more of these fixed instruments all transmitting data to a central control center. These types of scour monitors are being used in a wide variety of climates and temperatures, and in a wide range of bridge and channel types throughout the United States.

9.3.5 NCHRP Project 20-5

Most of the information in Section 9.3.4 is derived from NCHRP Project 20-5 (Topic 36-02) which was a synthesis study entitled *Practices for Monitoring Scour Critical Bridges* (Hunt 2008). The study assessed the state of knowledge and practice for fixed scour monitoring of scour critical bridges. It included a review of the literature and research, and a survey of transportation agencies and other bridge owners to obtain their experience with fixed scour monitoring systems.

The study found that 30 of the 50 states use, or have employed fixed scour monitoring instrumentation for their highway bridges. A total of 120 bridge sites were identified that have been instrumented with fixed monitors. The five types of fixed instruments being used in 2007 included sonars, float-outs, tilt meters, magnetic sliding collars and time domain reflectometers.

The site conditions and the types of bridges that were monitored with fixed scour instrumentation varied in many aspects. There were small to long span bridges with lengths ranging from 41 ft (12.5 m) to 12,865 ft (3,921 m). The Average Daily Traffic (ADT) ranged from 400 to 175,000 vehicles per day, and the bridges were constructed between 1920 and 1986. The site conditions included both riverine and tidal waterways, intermittent to perennial flows, and water depths ranging from less than 10 to 75 ft (3 m to 30 m). The soil conditions ranged from clay to gravel, and some had riprap protection.

The scour monitors were installed between 1992 and 2007. The earlier installations included sounding rods, magnetic sliding collars and sonars. More recent installations also include float-outs, tilt sensors and TDRs. The sonar scour monitoring system is the most commonly used device, installed at 70 of the 120 bridge sites. This was followed by the magnetic sliding collar at 21 sites. The bridge owners reported that 90% of the structures monitored with fixed instruments were piers. The remaining devices were on abutments, or in the vicinity of the bridge on bulkheads or downstream countermeasure protection.

The survey respondents indicated that high velocity flows, debris, ice forces, sediment loading and/or low water temperatures were extreme conditions that were present at the monitored bridge sites. The debris and ice forces caused the majority of damage and interference to the scour monitoring systems. They noted that the extent and frequency of the damage was often not anticipated by the bridge owner and this resulted in much higher maintenance and repair costs than anticipated.

The bridge owners provided information on their future needs for improved scour monitoring technology which include:

- More robust devices – increased reliability and longevity
- Decreased costs
- Less maintenance
- Devices more suitable for larger bridges
- Devices that measure additional hydraulic variables and/or structural health

9.3.6 Application Guidelines

Bridge Pier and Abutment Geometry. It is clear that no single device is applicable to all bridge pier and abutment geometries. However, most bridge geometries can be accommodated with one of the scour measuring devices described in Section 9.3.4.

Most instruments are adaptable in some degree to vertical piers and abutments. Sloping piers and spill-through abutments present difficulties for most instrument configurations; however, driven rod instruments, such as the automated sliding collar, that are not fastened to the substructure can be used on sloping piers and abutments. Adapting scour instrumentation to a large spread footing or pile cap configuration also presents challenges.

Flow and Geomorphic Conditions. Each class of scour measuring instrument will not be applicable to all flow and geomorphic conditions. While some limitations stem from the capabilities of the device itself, some pertain to whether the device is installable given the geomorphic and flow conditions. For example, sounding rods have not performed well in sand-bed streams, although the addition of a large base plate to the sounding rod could help correct the problem, and sonar devices may be best suited for tidal waterways where problems with debris are not as common as they are for riverine bridges.

All devices using a driven rod configuration (including TDR) will have limitations imposed by bed and substrate characteristics. Pre-drilling, jetting, or augering may permit installation under a wide range of conditions, but these techniques may be expensive and could be difficult over water. The connecting conduit required by the manual-readout sliding collar device is vulnerable to ice and debris impact, but the instrument proved surprisingly durable at field test sites with significant debris.

Low-cost fathometers are applicable to a wide range of streambed characteristics and flow and geomorphic conditions, but ice and debris in the stream can quickly render a fathometer inoperable. Strategies such as placing the transducer close to the streambed may reduce, but won't eliminate, the vulnerability of this instrument to ice and debris.

Float out devices are simple to fabricate and relatively inexpensive. Installation in the dry on an ephemeral stream or where a coffer dam can be installed can be accomplished with drilling equipment available to most DOTs. Installation under water, however, would be difficult.

Tilt Meters. Tilt meters are placed on the bridge superstructure and above-water substructure components making installation easier and less expensive than other fixed instruments. Tilt meters measure the movement of the bridge itself, therefore the bridge must be redundant enough to withstand some movement without failure (Avila et al. 1999). This will allow maintenance forces sufficient time to remotely observe the movement and

send crews to inspect the bridge and close it, if necessary. However, it is difficult to set the magnitude of the angle at which the bridge is in danger. Bridges are not rigid structures, and movement can be induced by traffic, temperature, wind, hydraulic and earthquake loads. It is necessary to observe the "normal" movement of the bridge and then determine the "alarm" angle that would provide sufficient time for crews to travel to and close the bridge to traffic. The California Department of Transportation (Caltrans) has accomplished this by installing the tilt meters, monitoring normal pier movement for several months (ideally, they recommend one year), and setting the "alarm" angles based on the unique "signature" of each monitored pier on any given bridge.

9.4 SELECTING INSTRUMENTATION

Developing the monitoring program in a Plan of Action requires identifying the specific instruments, portable and/or fixed, and how they will be used to monitor scour. Selection of the appropriate instrumentation will depend on site conditions (streambed composition, bridge height off water surface, flow depth and velocity, etc.) and operational limitations of specific instrumentation (e.g., as related to high sediment transport, debris, ice, specialized training necessary to operate a piece of equipment, etc.).

Engineering judgment will always be required in designing instrument specifications to maximize the scour information collected within the given resources. Specific issues related to the use of either fixed or portable instruments include:

1. For fixed instrumentation, the number and location of instruments will have to be defined, as it may not be practical or cost effective to instrument every pier and abutment.
2. For portable instrumentation, the frequency of data collection and the detail and accuracy required will have to be defined, as it may not be possible to complete detailed bathymetric surveys at every pier or abutment during every inspection.

Some monitoring programs will involve a mix of fixed, portable and geophysical instruments to collect data in the most efficient manner possible. Furthermore, portable instrumentation should be used to ground-truth fixed instrumentation to insure accurate results and to evaluate potential shifting of the location of maximum scour.

Table 9.1 summarizes the advantages and limitations of the various instrumentation categories. In general, fixed instrumentation is best used when ongoing monitoring is required, recognizing that the location of maximum scour may not always be where the instrument was originally installed. This could be the result of geomorphic conditions and changes in the river over time, or an initial miscalculation when the instrument was installed. Portable instruments are best used where more areal coverage is required, either at a given bridge or at multiple bridges. Portable instruments provide flexibility and the capability to respond quickly to flood conditions; however, if a portable monitoring program becomes large, collecting data may become very labor intensive and costly. Additionally, deployment of portable instruments may require specialized platforms, such as trucks with cranes or booms, or the use of an under bridge inspection truck. Geophysical instrumentation is best used as a forensic tool, to evaluate scour conditions that existed during a previous flood. The primary limitation of geophysical equipment is the specialized training and cost involved in deploying this type of measurement.

Instrument Category	Advantages	Limitations
Fixed	Continuous monitoring, low operational cost, easy to use	Maximum scour not at instrument location, maintenance/loss of equipment
Portable	Point measurement or complete mapping, use at many bridges	Labor intensive, special platforms often required
Geophysical	Forensic investigations	Specialized training required, labor intensive
Positioning	Necessary for portable and geophysical instruments	

9.4.1 Portable Instruments

Within the portable instrument category, the use of physical probes is generally limited to smaller bridges and channels (Table 9.2). It is a simple technology that can be effectively used by personnel with limited training, but may be of limited use as the flow depth or velocity increase, such as during flood conditions. Portable sonar instruments may be better suited for large bridges and channels, but they too can be limited by flow conditions based on the deployment options available. Sonar may also be limited in high sediment or air entrainment conditions, or when debris or ice accumulation are present.

	Best Application	Advantages	Limitations
Physical Probes	Small bridges and channels	Simple technology	Accuracy, high flow application
Sonar	Larger bridges and channels	Point data or complete mapping, accurate	High flow application

Positioning equipment is required to provide location information with any portable or geophysical measurement (Table 9.3). The approximate methods are useful for any type of reconnaissance or inspection level monitoring, but are obviously limited by accuracy. The use of standard land survey techniques, using a total station type instrument or in the case of hydrographic surveying, an automated range-azimuth type device, can provide very accurate positional data. However, these instruments require a setup location on the shoreline that may be difficult to find during flooding, when overbank water and/or riparian vegetation limit access and line-of-sight. These approaches can also be somewhat slow and labor intensive. In contrast, the use of GPS provides a fast, accurate measurement, but will not work under the bridge.

	Best Application	Advantages	Limitations
Approximate methods	Recon or inspection	No special training or equipment	Accuracy
Traditional land survey methods	Small channels or areal surveys	Common technique using established equipment	Shore station locations, labor intensive
GPS	Measurement up to bridge face	Fast, accurate	Cannot work under bridge

Another important factor in designing a monitoring program is the cost of the instrumentation and data collection program. Portable instrument costs can be readily identified, but the cost of installation and operation are more difficult to quantify, since this will depend on site specific conditions and the amount of data needed. Based on field experience, Table 9.4 provides general guidelines on cost information. These costs should be used cautiously in an absolute sense, given unique site-specific conditions and/or the changes in cost that can occur with time and new research and development. This information may be most useful as a relative comparison between different approaches.

	Instrument Cost	Cost for Installation or Use	Operation Cost
Physical Probes	< \$500	varies by use	varies, minimum 2-person crew for safety
Portable Sonar	fish-finder - \$500; survey grade - \$15,000 +/-	varies by use	varies, minimum 2-person crew for safety
Traditional land survey	\$10,000 +/-	varies	2-3 person crew
GPS	\$5,000 for submeter accuracy, \$20,000 + for centimeter	varies	1-2 person crew

9.4.2 Fixed Instruments

Fixed instrument devices include sonar, sounding rods (automated physical probe), magnetic sliding collar, float out devices, tilt sensors, and time domain reflectometers (Table 9.5). Based on field experience, the sonar type devices work best in coastal regions and can be built using readily available components. They provide a time history of scour, yet have difficulty in conditions with high debris, ice, and air entrainment (Zabilansky 1996). Therefore, if a sonar device is selected for a riverine environment, these conditions may limit when data is collected and the quality of the data record.

Type of Fixed Instrumentation	Best Application	Advantages	Limitations
Sonar	Coastal regions	Records infilling; time history; can be built with off the shelf components	Debris, high sediment loading, ice, and air entrainment can interfere with readings
Magnetic Sliding Collar	Fine bed channels	Simple, mechanical device	Vulnerable to ice and debris impact; only measures maximum scour; unsupported length, binding
Tilt Sensors	All	May be installed on the bridge structure and not in the stream-bed and/or underwater	Provides bridge movement data which may or may not be related to scour
Float-Out Device	Ephemeral channels	Lower cost; ease of installation; buried portions are low maintenance and not affected by debris, ice or vandalism	Does not provide continuous monitoring of scour; battery life
Sounding Rods	Coarse bed channels	Simple, mechanical device	Unsupported length, binding, augering
Time Domain Reflectometers	Riverine ice channels	Robust; resistance to ice, debris, and high flows	Limit on maximum lengths for signal reliability of both cable and scour probe

Sounding rods, typically a dropping rod with a method to measure the displacement occurring, have been found to work best in coarse bed channels, and are a simple mechanical type of device. They have had difficulty in channels with fine sediments where sediment accumulation around the sliding components has led to binding. Additionally, they are limited by the maximum amount of travel that the sounding rod can realistically achieve, given problems with unsupported length vibration and augering. In contrast, the magnetic sliding collar device works best in fine bed channels, where it is possible to drive the supporting rod into the streambed. It, too, is a simple mechanical type device, but it is also limited by concerns with unsupported length, binding and debris.

The float-out type sensors have worked well in ephemeral channels, and are a low-cost addition to any other type of fixed instrument installation. They have been successfully used when buried either in the channel bed, or in riprap, and can be placed at locations away from structural members of the bridge, which may not be possible with the other types of fixed instruments.

Tilt sensors are installed above water on the bridge superstructure or substructure and may be used on a wide variety of bridges and sites. They measure overall structure movement and, therefore, do not have to be located at the specific location of the scour, as is the case with the other fixed instruments discussed in this chapter. Tilt sensors do not provide information on scour depths. The bridge must be redundant enough to ensure that when movement is detected there is enough time to close or repair the bridge. In addition, bridge movements and rotations may be caused by a variety of load factors, and it may take some time to establish the "signature" movements particular to a bridge which are not due to scour.

The fixed instrumentation selection matrix, Table 9.6 was developed during the synthesis study (Hunt 2008) to complement the countermeasure selection matrix (Table 2.1). See Chapter 2, Section 2.3 for a discussion of the various symbols used in both tables. If fixed instrumentation is to be used to monitor a bridge, this table provides additional items to be considered in deciding between the various fixed instrument options. It was developed based on the results of the synthesis study state survey and literature search (Section 9.3.5). Table 9.6 includes additional categories for suitable river environment for the various fixed instruments:

- Type of waterway – riverine / tidal
- Flow habit
- Water depth
- Bed material
- Extreme conditions

The bridge geometry includes information on the characteristics of the bridges for the different types of instruments:

- Foundation type

The table includes additional items regarding the monitoring system capabilities which may be mandatory or desirable criteria for a particular bridge site:

- Continuous data monitoring
- Remote technology

Additional river environment factors listed in Table 2.1 (river type, stream size, bend radius, bank slope, and floodplain) are not listed in Table 9.6 as they do not directly influence the selection of fixed instrumentation.

Table 9.6. Fixed Instrumentation Selection Matrix.

Type of Fixed Instrumentation	FUNCTIONAL APPLICATIONS				SUITABLE RIVER ENVIRONMENT										Additional Installation Experience by State from Other Sources			
	Local Scope	Piers	Abutments	Instrumentation	Contraction Scour	Stream Intensity	Waterway Type	Flow	Water Depth	Bed Material	Excess Conditions	Foundation Type	Capabilities	Maintenance		Survey Respondents	Installation Experience	
Sonar	●	●	●	●	●	●	●	●	●	●	●	✓	Yes	Yes	48	164	AK, AR, CA, FL, GA, HI, IL, IN, KS, MD, NC, NJ, NY, NY, TX, VA, WA	CO, NM, OR, RI, WI
Magnetic Sliding Collar	●	●	●	●	●	●	●	●	●	●	●	✓	Yes	Yes	8	22	CA, HI, IN, MN, NJ, NY	CO, FL, ME, MI, NM, RI, TX, WI
Tilt Sensors	●	●	●	●	●	●	●	●	●	●	●	✓	Yes	Yes	4	35	CA, WA	
Float Out Device	●	●	●	●	○	●	●	●	●	●	●	✓	No	Yes	3	35	AL, CA, NY	AZ
Sounding Rods	●	●	●	●	●	●	●	●	●	●	●	T, S	Yes	No	0	0		AR, IA, NY
Time Domain Reflectometers	●	●	●	●	○	●	●	●	●	●	●	✓	Yes	Yes	1	2		VT

- Well suited/primary use
- Possible application/secondary use
- Unusable/rarely used
- N/A Not applicable
- ✓ Suitable for the full range of the characteristics/conditions

The installation experience by state for each type of fixed monitor for those that responded to the synthesis survey (Section 9.3.5) and also from the literature search are included in the last two columns of Table 9.6.

The cost of fixed instrumentation and the data collection program is an important factor in the selection process. Table 9.7 provides general guidelines on cost information. This table may be used with Table 9.4 for portable instruments to compare relative cost information between the different monitoring approaches. As with portable instruments, the most quantifiable cost for fixed instrumentation is the equipment cost. The installation, operation, maintenance and repair costs are more difficult to ascertain.

Typed of Fixed Instrumentation	Instrument Cost with Remote Technology (\$) ⁽¹⁾	Instrument Cost for Each Additional Location (\$)	Installation Cost	Maintenance/ Operation Costs
Sonar	12,000 - 18,000	10,000 - 15,500	Medium to high; 5 to 10-person days to install	Medium to High
Magnetic Sliding Collar	13,000 - 15,500	10,500 - 12,500	Medium, minimum 5-person days to install	Medium
Tilt Sensors	10,000 - 11,000	8,000 - 9,000	Low	Low
Float-Out Device	10,100 - 10,600	1,100 - 1,600	Medium; varies with number installed	Low
Sounding Rods	7,500 - 10,000	7,500 - 10,000	Medium; minimum 5-person days to install	High
Time Domain Reflectometers	5,500 - 21,700	500	Low	Medium

⁽¹⁾Cost per device will decrease when multiple devices share remote stations and/or the master station.

Instrument costs generally include the basic scour monitoring instrument and mounting hardware, as well as power supply, data logger and instrument shelter/enclosure, where applicable. This cost may not include miscellaneous items to install the equipment such as electrical conduit, brackets and anchor bolts which may be included as part of the contractor installation cost.

The cost of the scour monitoring installations can vary dramatically due to different factors such as site conditions, the group and/or the experience of the personnel installing the equipment, the type of contract, and the installation requirements. Larger bridges and deeper waterways are more expensive to instrument than smaller bridges in ephemeral or low water crossings. Scour monitors may be installed at certain sites by the state maintenance group, or another agency with equipment they own, or by students. More complicated installations and sites may require specialized contractors and construction equipment to install the scour monitoring devices.

Most recent installations of fixed instrumentation have used remote technology to download data to avoid repeated visits to the bridge site. Although this increases the initial equipment cost, it can substantially reduce the long-term operational costs of data retrieval. Site data retrieval involves sending crews to the bridge and access may include security clearance, lane or bridge closures, and equipment such as snooper trucks or boats. Remote technology can also increase safety to the traveling public because it permits real-time monitoring during the storm events which may result in earlier detection of scour.

Factors that contribute to increased scour monitoring installation, inspection, maintenance and repair costs include: larger bridges; complex pier geometries; bridges with large deck heights off the water; deeper waterways; long distance electrical conduit runs; more durable materials required for underwater tidal installations; the type of data retrieval required (i.e., Internet, satellite); lane or bridge closures and maintenance-of-traffic; and installation and access equipment such as boats, barges, snooper trucks, drills and diving teams.

9.5 FIXED INSTRUMENT CASE HISTORIES

9.5.1 Introduction

The following case histories were selected for this section because they cover a range of geographical locations and types of fixed scour monitoring instrumentation. This section provides descriptions of the systems as well as details on the installations and implementation of the scour monitoring programs.

9.5.2 Typical Field Installations

Alaska Installations. To better understand the scour process and to monitor bed elevation at bridge piers, the U.S. Geological Survey (USGS) and the Alaska Department of Transportation and Public Facilities operate a network of streambed scour-monitoring stations in Alaska (Conaway 2006a). To date they have instrumented 20 bridges with sonar and river stage instrumentation (Figure 9.22). In 2007, 16 bridges remained in the scour monitoring program. These stations provide state engineers with near real-time bed elevation data to remotely assess scour at bridge piers during high flows. The data also provide a nearly continuous record of bed elevation in response to changes in discharge and sediment supply. Seasonal changes as well as shorter duration scour and fill have been recorded. In addition to the near real-time data, channel bathymetry and velocity profiles are collected at each site several times per year.

Each bridge is instrumented with a retractable, pier-mounted sonar device. At locations with multiple scour critical piers, sonar transducers were mounted at each pier. The sonar transducers were mounted either at an angle on the side of the piers near the nose or on the pier nose in order to collect data just upstream of the pier footing. Many of Alaska's bridges are situated in locations too remote for landline or cellular telephone coverage. The scour monitoring instrumentation on the remote bridges has incorporated *Orbcomm*, a constellation of low-earth-orbiting satellites. Data is sent from the bridge to a passing satellite, which then relays it on to an earth station which then forwards the data to specified email addresses. The network of scour monitoring sites is dynamic, with locations being added and removed annually based on monitoring priority and the installation of scour countermeasures. Instrumentation is subject to damage by high flows, debris and ice, and repairs at some sites can only be made during low-flow conditions.

In 2002 one sonar scour monitor was installed at the Old Glenn Highway Bridge over the Knik River near Palmer (Figure 9.23) (Conaway 2006b). There are two bridges that cross the Knik River at this location. The active bridge was built in 1975, is 505 ft (154 m) in length, and is supported by two piers. The roadway approaches to the active bridge significantly contract the channel. Approximately 98 ft (30 m) upstream is the original bridge which is no longer open to vehicular traffic. Two guide banks extend upstream of both bridges and route flow through a riprap lined bridge reach. All piers are approximately aligned with the flow. The Knik River is a braided sand and gravel channel that transports large quantities of sediment from the Knik Glacier. The braided channel narrows from approximately 3 mi (4.8 km) wide at the glacier mouth to 0.07 mi (0.12 km) at the Old Glenn Highway Bridge where the channel is subject to a 4:1 contraction during summer high flows.

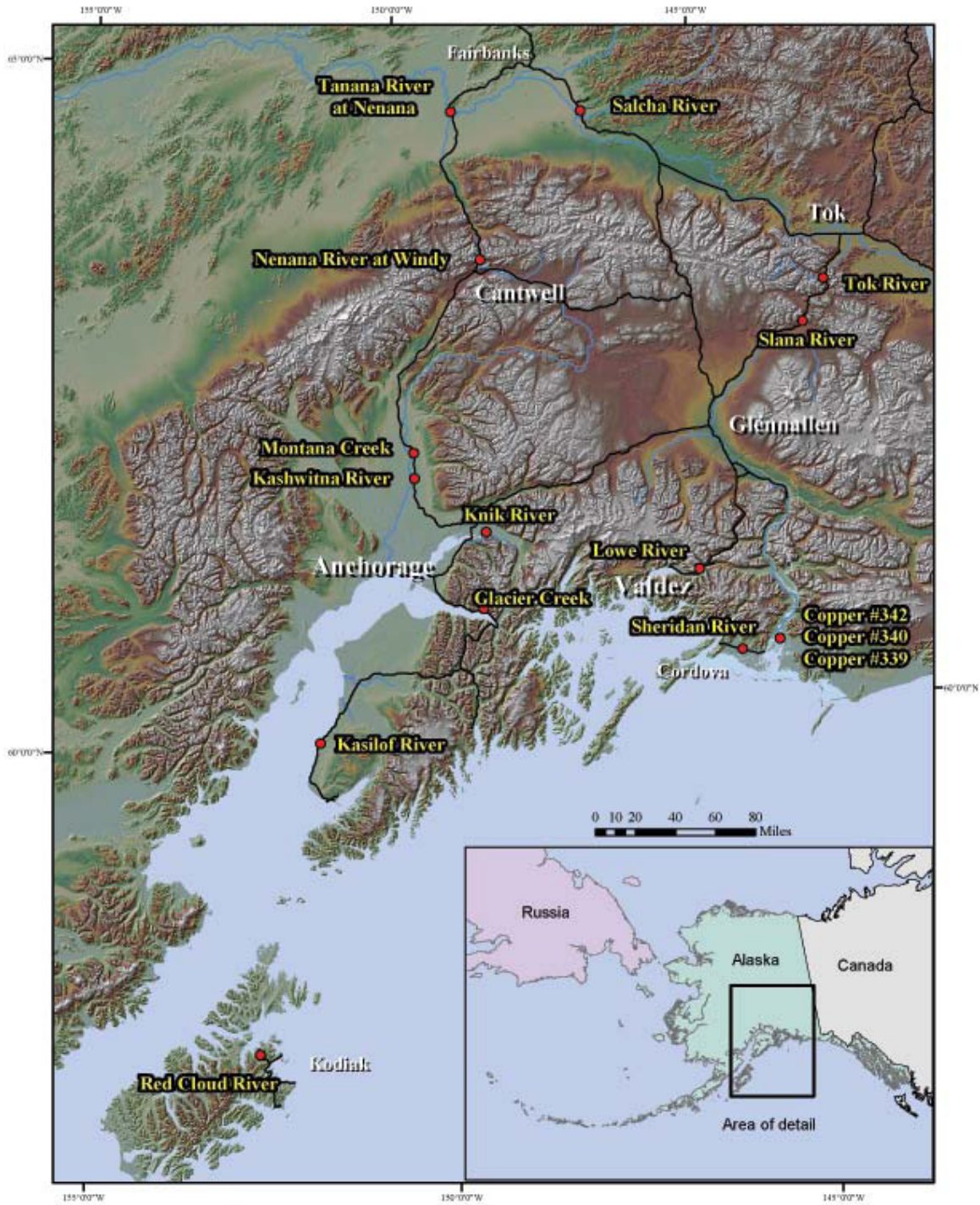

Figure 9.22. Active streambed scour monitoring locations in Alaska (Conaway 2006a).

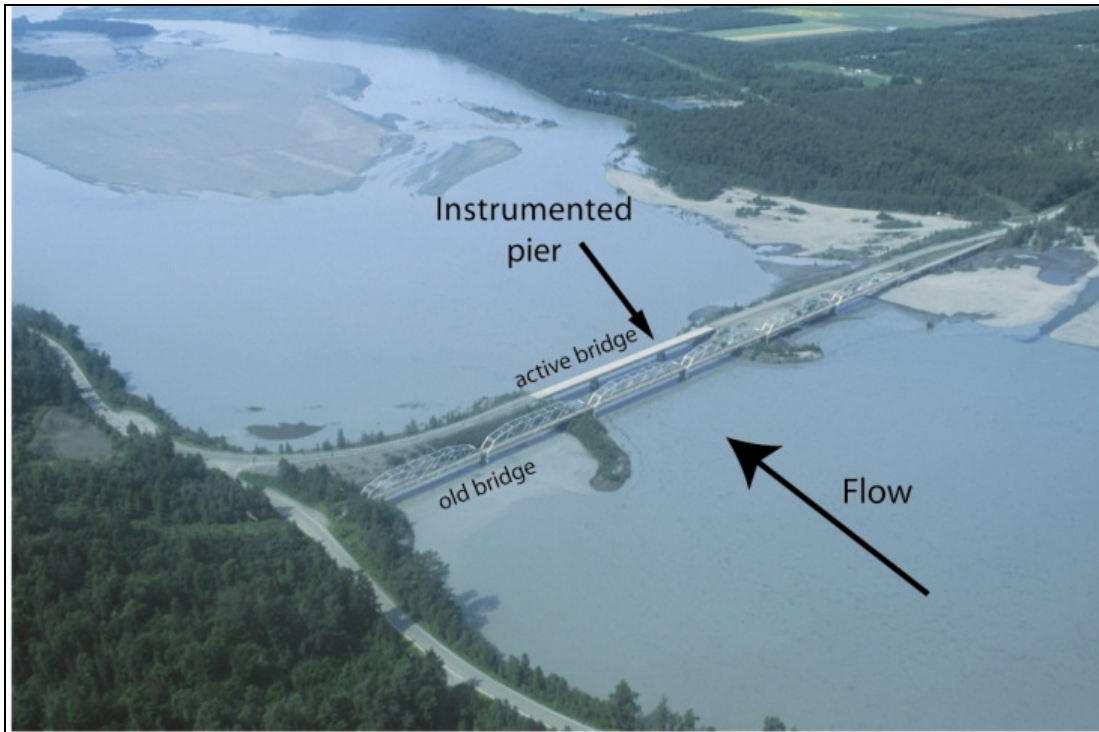

Figure 9.23. Oblique aerial photograph of the Knik River Old Glenn Highway bridges during a summer high flow (Courtesy of U.S. Geological Survey).

The right-bank pier of the new bridge was instrumented with a retractable, pier-mounted sonar monitor. This retractable arm was designed to prevent ice and debris flows from damaging the sonar bracket, as had occurred in other scour monitoring installations in Alaska. Stage data were measured by a nearby USGS stream gage. The sonar was mounted at an angle on the side of pier near the nose in order to collect data just upstream of the pier footing. Data are collected every 30 minutes and transmitted every 6 hours via satellite. When bed elevation or stage thresholds are exceeded, data transmissions increase in frequency. The Knik River was the only site within the monitoring network that had large changes in bed elevation each year. Annual scour ranged from 17.2 to 20 ft (5.2 m to 6.0 m). These near real-time data for the Knik River and other sites in Alaska are available on the USGS website.

New York Installations. NYSDOT has installed twenty-seven sonar scour monitors at three bridges on the South Shore of Long Island in Nassau and Suffolk Counties in New York (Hunt 2003). Wantagh Parkway over Goose Creek is a 93 ft (28.3 m) bascule bridge (Figure 9.24), Wantagh Parkway over Sloop Channel was a 576 ft (175.6 m) long bridge, and Robert Moses Causeway over Fire Island Inlet, a 1,068 ft (326 m) bridge (Figure 9.25). These have served as both short and long-term solutions to the scour problems at these bridges. In 1998, following a partial pier collapse at Wantagh Parkway over Goose Creek, it was found that the streambed at one pier had experienced approximately 29 ft (8.8m) of localized scour since it was built in 1929. In order to ensure that these bascule piers were safe, several options were investigated and a scour monitoring system and program was designed for the bridge.

A nearby bridge, Wantagh Parkway over Sloop Channel was also examined. It was found to have similar problems with respect to scour of the piers. As a result, four scour monitors were installed at the bascule piers of Goose Creek, and ten monitors were installed at Sloop Channel. In addition, a water stage sensor was installed at each bridge. The scour monitors were approved by NYSDOT within one week of the 1998 failure, and they were designed, custom-built and arrived at the site ten weeks later. The sonar mounting brackets were made of stainless steel due to the harsh tidal environment. For data retrieval the system employed remote telemetry via a modem and telephone landline. The power was supplied using solar panels for the fixed bridge at Sloop Channel and using the electrical system on the bascule bridge at Goose Creek.



Figure 9.24. Conduit to sonar scour monitor at Wantagh Parkway over Goose Creek.

A scour monitoring program and manual were developed for the Wantagh Parkway Bridges. This was the first procedural manual to be developed for scour monitors. The manual provided the opportunity to work through various scenarios should these bridges continue to experience scour. The program included round-the-clock monitoring even during storms. It included critical streambed elevations for each pier, procedures for normal and emergency situations, a Plan of Action should certain scour elevations be reached and troubleshooting, maintenance and servicing instructions. An effective communication system for all responsible parties was established.

The installation of sonar scour monitors at Robert Moses Causeway over Fire Island Inlet is a long-term solution to the scour issues at that bridge. The flow rate was estimated to be over 492,000 cfs (13,932 m³/sec) for the 100-year storm. Riprap scour protection had been placed at some piers over the years, and according to the FHWA guidance, riprap should be monitored when used as a countermeasure at piers. In 2001, sonar scour monitors were placed at 13 piers, a water stage sensor was installed, and the Long Island scour monitoring manual was revised to include the new system. This was a complex design and installation due to the proximity of the bridge to the Atlantic Ocean, the deep-water conditions, the pier configurations and the high flow rates. In order to ensure that the underwater sonar brackets could clear the pier footings to measure the streambed elevations, this design incorporated a new type of adjustable tripod stainless steel bracket (Figure 9.26).



Figure 9.25. Solar panel, remote station and (inset) conduit to sonar monitor at Robert Moses Causeway over Fire Island Inlet.



Figure 9.26. Adjustable stainless steel sonar mounting bracket prior to underwater installation.

Summary – New York Installations. The scour monitoring systems at Goose Creek and Fire Island have been in operation for since 1998 and 2001, respectively (Hunt and Price 2004). When the Sloop Channel Bridge was replaced in 1999, the monitoring system was salvaged and has been used for spare parts for the other bridges. The scour monitoring program includes the routine monitoring of these bridges, including data acquisition and analysis; round-the-clock monitoring during scour critical events; the preparation of bi-weekly graphs of the streambed elevations and tide gage data; periodic data reduction analyses and graphs; and routine maintenance, inspection, and repairs. In 2004, a total refurbishment of the Goose Creek system was completed. This included the installation of the latest operating system software and a new bracket for the sonar transducer at one monitor location. An underwater contractor installed the new bracket and also strengthened the scour monitor mountings at the other three pier locations. The condition of the scour monitors and the accuracy of their streambed elevation readings are checked during the regularly scheduled diving inspections at each bridge. Also, substantial marine growth and/or debris on the underwater components is cleared away during these inspections.

California, Arizona and Nevada Installations. In preparation for El Niño driven storm events, a variety of instruments were installed at bridges in the southwest in late 1997 and early 1998. Five bridges were instrumented in California, five in Arizona and four in Nevada. The equipment included automated sliding collar devices, low-cost sonar, multi-channel sonar, float-out transmitters and sliding rod devices (Figures 9.27 and 9.28). These installations provided an opportunity to test a number of new concepts, including 2- and 4-channel sonar devices, application of early warning concepts (by defining threshold scour levels and automated calls to pagers when that threshold was exceeded), and development and refinement of the float-out instrument concept.



Figure 9.27. Installation of a sonar scour monitor on Salinas River Bridge near Soledad, California (Highway 101) by CALTRANS.



Figure 9.28. Close up of sonar scour monitor on Salinas River Bridge near Soledad, CA.

To support the California, Arizona, and Nevada installations, a buried transmitter float-out device was developed for application on bridge piers over ephemeral stream systems. As summarized in Section 9.3.4, this device consists of a radio transmitter buried in the channel bed at a pre-determined depth. When the scour reaches that depth, the float out device rises to the surface and begins transmitting a radio signal that is detected by a receiver in an instrument shelter on the bridge. Installation requires using a conventional drill rig with a hollow stem auger (Figure 9.29). After the auger reaches the desired depth, the float out transmitter is dropped down the center of the auger (Figure 9.30). Substrate material refills the hole as the auger is withdrawn.

The float out device can be monitored by the same type of instrument shelter/data logger currently being used to telemeter low-cost fathometer or automated sliding collar data. The instrument shelter contains the data logger, cell-phone telemetry, and a solar panel/gell-cell battery for power (Figure 9.31). The data logger monitors the sliding collar and sonar scour instruments, taking readings every hour and transmitting the data once per day to a computer at a central location (e.g., DOT District). A threshold elevation is defined that, when reached, initiates a phone call to a pager network. The bridge number is transmitted as a numeric page, allowing identification of the bridge where scour has occurred. The float out devices are monitored continuously, and if one of these devices floats to the surface, a similar call is automatically made to the pager network.

Although the float out devices had not been tested extensively in the field, in late 1997 and early 1998 more than 40 float-out devices were installed at bridges in Arizona (4 bridges), California (1 bridge), and Nevada (4 bridges). Most devices were installed at various levels below the streambed as described above; however, several devices at bridges in Nevada were buried in riprap at the base of bridge piers to monitor riprap stability (Figure 9.32).



Figure 9.29. CALTRANS drilling with hollow stem auger for installation of float out devices at Salinas River Bridge (Highway 101) near Soledad, CA.



Figure 9.30. Installation of float out device on Salinas River Bridge near Soledad, CA.



Figure 9.31. Typical instrument shelter with data logger, cell-phone telemetry, and a solar panel/gel-cell for power.



Figure 9.32. Installation of a float out device by Nevada DOT to monitor riprap stability.

One of the bridges instrumented experienced several scour events that triggered threshold warnings during February 1998. In one case the automated sliding collar dropped 5 ft (1.5 m) causing a pager call-out. Portable sonar measurements confirmed the scour recorded by the sliding collar. Several days later, another pager call-out occurred from a float-out device buried about 13 ft (4 m) below the streambed.

In both cases, the critical scour depth was about 20 ft (6 m) below the streambed. However; pager call-out was ineffective in alerting maintenance personnel during non-office hours and no emergency action was called for to insure public and/or bridge safety. Consequently, a programmed voice synthesizer call-out to human-operated 24-hour communications centers was implemented at other bridges. This illustrates the importance of effective and well-defined communication procedures, and the on-going need for comprehensive scour training at all levels of responsibility.

(page intentionally left blank)

CHAPTER 10

REFERENCES

- Atayee, A. Tamin, 1993, "Study of Riprap as Scour Protection for Spill Through Abutment," presented at the 72nd Annual TRB meeting in Washington, D.C., January.
- Avila, C.M.C., Racin, J.A. and Davies, P., 1999, "Talk to Your Bridges and They Will Talk Back – Caltrans Bridge Scour Monitoring Program," *Proceedings from the ASCE Hydraulic Engineering Conference*, Seattle, WA.
- Ayres Associates Inc, 1999, "A-Jacks Concrete Armor Units Channel Lining and Pier Scour Design Manual," Prepared for Armortec, Inc., Bowling Green, KY.
- Barkdoll, B.D., Ettema, R., and Melville, B.W., 2007, "Countermeasures to Protect Bridge Abutments from Scour," NCHRP Report 587, Transportation Research Board, National Academies of Science, Washington, D.C.
- Barksdale, G. 1994, "Bridge Scour During the 1993 Floods in the Upper Mississippi River Basin," proceeding of the 1994 ASCE Hydraulic Engineering Conference.
- Bath, W.R., 1999, "Remote Methods of Underwater Inspection of Bridge Structures," FHWA Report RD-99-100, Turner-Fairbank Highway Research Center, McLean, VA.
- Begin, Z.B., 1981, "Stream Curvature and Bank Erosion: A Model Based on the Momentum Equation," *Journal of Geology*, Vol. 89, pp. 497-504.
- Bentrup, G. and Hoag, J.C., 1998, "The Practical Streambank Bioengineering Guide: User's Guide for Natural Streambank Stabilization Techniques in the Arid and Semi-Arid Great Basin and Intermountain West," Interagency Riparian/Wetland Plant Development Project, USDA Natural Resources Conservation Service.
- Bertoldi, D. and Kilgore, R., 1993, "Tetrapods as a Scour Countermeasure, Proceedings Hydraulic Engineering '93," Vol. 2, 25-30 July 1993, San Francisco, CA, pp. 1385-1390.
- Bertoldi, D.A., Jones, S.J., Stein, S.M., Kilgore, R.T., and Atayee, A.T., 1996, "An Experimental Study of Scour Protection Alternatives at Bridge Piers," FHWA-RD-95-187, Federal Highway Administration, Washington, D.C.
- Blodgett, J.C. and McConaughy, C.E., 1986, "Rock Riprap Design for Protection of Stream Channels Near Highway Structures," Volume 1 – Hydraulic Characteristics of Open Channels, U.S. Geological Survey, Water Resources Investigations Report 86-4127, prepared in Cooperation with Federal Highway Administration, Sacramento, CA.
- Blodgett, J.C. and McConaughy, C.E., 1986, "Rock Riprap Design for Protection of Stream Channels Near Highway Structures," Volume 2 – Evaluation of Riprap Design Procedures, U.S. Geological Survey, Water Resources Investigations Report 86-4128, prepared in Cooperation with Federal Highway Administration, Sacramento, CA.

- Bradley, J.N., 1978, "Hydraulics of Bridge Waterways," Hydraulic Design Series No. 1, U.S. Department of Transportation, FHWA, Washington, D.C.
- Brebner, A., 1978, "Performance of Dolos Blocks in an Open Channel Situation," Proceedings 16th Annual Conference on Coastal Engineering, Hamburg, West Germany, August, pp. 2305-2307.
- Brice, J.C., 1981, "Stability of Relocated Stream Channels," FHWA/RD-80/158, Federal Highway Administration, Washington, D.C., March.
- Brice, J.C., 1984, "Assessment of Channel Stability at Bridge Sites," Transportation Research Record, Vol. 2, No. 950, Transportation Research Board, 2101 Constitution Avenue, Washington, D.C. 20418.
- Brice, J.C. and Blodgett, J.C., 1978, "Countermeasure for Hydraulic Problems at Bridges, Volumes 1 and 2," FHWA-RD-78-164 and 163, USGS, Menlo Park, CA.
- Brown, S.A., 1985, "Streambank Stabilization Measures for Highway Engineers," FHWA/RD-84/100, Federal Highway Administration, Washington, D.C.
- Brown, S.A. and Clyde, E.S., 1989, "Design of Riprap Revetment," Hydraulic Engineering Circular No.11, FHWA-IP-89-016, prepared for the Federal Highway Administration, Washington, D.C.
- Brown, S.A., R.S. McQuivey, and T.N. Keefer, 1980, "Stream Channel Degradation and Aggradation: Analysis of Impacts to Highway Crossings," FHWA/RD-80-159, Federal Highway Administration, Washington, D.C.
- Butch, G., 1996, "Evaluation of Scour Monitoring Instruments in New York," 1996 North American Water and Environment Congress '96--Bridge Scour Symposium, Hydraulics Division, American Society of Civil Engineers, Anaheim, CA , June 22-28.
- Bunte, K. and Abt, S.R., 2001, "Sampling Surface and Subsurface Particle-Size Distributions in Wadable Gravel- and Cobble-Bed Streams for Analyses in Sediment Transport, Hydraulics, and Streambed Monitoring," Gen. Tech. Rep. RMRS-GTR-74, U.S. Department of Agriculture, Forest Service, Rocky Mountain Research Station, Fort Collins, CO, 428 p.
- Burns, R.S., Fotherby, L.M., Ruff, J.F., and Carey, J.M., 1996, "Design Example for Bridge Pier Scour Measures Using Toskanes," Transportation Research Board, Transportation Research Record 1523, pp. 173-177.
- Chiew, Y.M., 1995, "Mechanics of Riprap Failure at Bridge Piers," ASCE Journal of Hydraulic Engineering, Vol. 121, No. 9, pp. 635-643.
- Colson, B.E. and Wilson, K.V., 1973, "Hydraulic Performance of Bridges - Efficiency of Earthen Spur Dikes in Mississippi," MSHD-RD-73-15-SD, Mississippi State Highway Department, Jackson, Mississippi, in cooperation with the Federal Highway Administration.
- Comité Européen Normalisation (CEN), 2002, "European Standard for Armourstone," Report prEN 13383-1, Technical Committee 154, Brussels, Belgium.

Conaway, J.S., 2006(a), "Temporal Variations of Scour and Fill Processes at Selected Bridge Sites in Alaska," *Proceedings from the Federal Interagency Sedimentation Conference*.

Conaway, J.S., 2006(b), "Comparison of Long-Term Streambed Scour Monitoring Data with Modeled Values at the Knik River, Alaska," *Proceedings from the 3^d International Conference on Scour and Erosion*, Amsterdam, The Netherlands.

Crumrine, M.D., Lee, K.K., and Kittelson, R.L., 1996, "Bridge-Scour Instrumentation and Data for Nine Sites in Oregon, 1991-94," *U.S. Geological Survey Open-File Report 95-366*, prepared in cooperation with the Oregon Department of Transportation, Portland, OR.

Eisenhauer, N.O. and Rossbach, B. 1999, "Testing the Effectiveness of Scour Countermeasures by Physical Modeling," Federal Waterways Engineering and Research Institute (BAW), Karlsruhe, Germany, proceedings of the Transportation Research Board, 5th International Bridge Engineering Conference, April 3-5, 2000, Tampa, FL.

Escarameia, M., 1998, "River and Channel Revetments - A Design Manual," Environment Agency R&D Publication 16, Thomas Telford, London.

Federal Highway Administration, 1981, "Standard Specifications for Construction of Roads and Bridges on Federal Highway Projects," U.S. Department of Transportation, FP-79 (Revised June 1981, Washington D.C.

Federal Highway Administration, 1995, "Recording and Coding Guide for the Structure Inventory and Appraisal of the Nation's Bridges, Report No. FHWA-PD-96-001, U.S. Department of Transportation, Washington, D.C.

Federal Highway Administration, 1998, "Scour Monitoring and Instrumentation," Demonstration Project 97 Participants Workbook, FHWA-SA-96-036, Office of Technology Applications, Washington, D.C.

Federal Highway Administration, 2001, "Revision of Coding Guide, Item 113 – Scour Critical Bridges," Memorandum, HIBT-30, April 27, Washington, D.C.

Federal Interagency Stream Restoration Working Group (FISRWG), 1998, "Stream Corridor Restoration: Principles, Processes, and Practices," U.S. Dept. of Commerce, National Technical Information Service, Washington, D.C.

Fotherby, L.M., 1992, "Footings, Mats, Grout Bags, and Tetrapods; Protection Methods Against Local Scour at Bridge Piers," MS Thesis, Colorado State University, Fort Collins, CO.

Fotherby, L.M., 1993, "Alternatives to Riprap for Protection Against Local Scour at Bridge Piers," *Transportation Research Record* 1420, pp. 32-38.

Fotherby, L.M., 1995, "Scour Protection at Bridge Piers: Riprap and Concrete Armor Units," Ph.D. Dissertation, Colorado State University, Fort Collins, CO.

Fotherby, L.M. and Ruff, J.F., 1998, "Sizing Riprap and Concrete Armor Units at Bridge Piers," *Transportation Research Board*, 77th Annual Meeting, 11-15 January 1998, Washington, D.C., Paper No. 980633.

Fotherby, L.M. and Ruff, J.F., 1999, "Riprap and Concrete Armor to Prevent Pier Scour," In: Richardson, E.V. and Lagasse, P.F. (Eds.), *Stream Stability and Scour at Highway Bridges*, Compendium of Papers ASCE Water Resources Engineering Conferences 1991 to 1998, pp. 893-904.

Freeman, G.E. and Fischenich, J.C., 2000, "Gabions for Streambank Erosion Control," EMRRP Technical Notes Collection, ERDC TN-EMRRP-SR-22, U.S. Army Engineer Research and Development Center, Vicksburg, MS.

Galay, V.J., Yaremko, E.K, and Quazi, M.E., 1987, "River Bed Scour and Construction of Stone Riprap Protection," in Hey, R.D., Bathurst, J.C., and Thorne, C.R. (Eds.), *Sediment Transport in Gravel-Bed Rivers*, John Wiley & Sons Ltd., pp. 353-383.

Ginsberg, A. and Schall, J.D., 1998, "Impact of Scour Monitoring and Instrumentation in the United States," ASCE, *Proceedings of Water Resources Engineering '98*, Memphis, TN, August 3-7.

Gorin, S.R. and Haeni, F.P., 1989, "Use of Surface-Geophysical Methods to Assess Riverbed Scour at Bridge Piers," *Water Resources Investigations Report 88-4212*, U.S. Geological Survey, Reston, Virginia, Water Resources Div., in cooperation with Federal Highway Administration, Hartford, CT, 33 pp.

Gray, D.H. and Sotir, R., 1996, "Biotechnical and Soil Bioengineering Slope Stabilization," John Wiley and Sons, New York, NY.

Harris County Flood Control District, 2001, "Design Manual for Articulating Concrete Block Systems," prepared by Ayres Associates, Project No. 32-0366.00, Fort Collins, CO.

Heibaum, M.H., 2000, "Scour Countermeasures Using Geosynthetics and Partially Grouted Riprap," Federal Waterways Engineering and Research Institute (BAW), Karlsruhe, Germany, proceedings of the Transportation Research Board, 5th International Bridge Engineering Conference, April 3-5, 2000, Tampa, FL.

Heibaum, M.H., 2002, "Geotechnical Parameters of Scouring and Scour Countermeasures," *Mitteilungsblatt der Bundesanstalt für Wasserbau Nr. 85*. (J. Federal Waterways Engineering and Research Institute, No. 85), Karlsruhe, Germany.

Henry, K.S., 1999, "Geotextile Reinforcement of Low-Bearing-Capacity Soils," Special Report 99-7, U.S. Army Corps of Engineers – Cold Regions Research and Engineering Laboratory, Hanover, NH 03755.

Hoffmans, G.J.C.M. and Verheij, H.J., 1997, "Scour Manual," A.A. Balkema: Rotterdam, Brookfield.

Hunt, B.E., 2003, "Pier Pressure," *Bridge Design & Engineering*, Issue No. 30, First Quarter.

Hunt, B.E., 2008, "Practices for Monitoring Scour Critical Bridges," NCHRP Project 20-5, Topic 36-02, Transportation Research Board, National Academies of Science, Washington, D.C. (to be published).

Hunt, B.E. and Price, G.R., 2004, "Scour Monitoring – Lessons Learned," *Proceedings from the 2nd International Conference on Scour and Erosion*, Nanyang Technological University, Singapore, pp.69-84.

Isbash, S.V., 1936, "Construction of Dams by Depositing Rock in Running Water," *Transactions, Second Congress on Large Dams*, U.S. Government Report No. 3, Washington D.C.

Johnson, A.W. and Stypula, J.M. (Eds.), 1998, "Guidelines for Bank Stabilization Projects in the Riverine Environments of King County," King County Department of Public Works, Surface Water Management Division, Seattle, WA.

Jones, J.S., 1989, "Laboratory Studies of the Effect of Footings and Pile Groups on Bridge Pier Scour," *Proceeding of 1989 Bridge Scour Symposium*, FHWA, Washington, D.C.

Jones, J.S., Bertoldi, D., and Stein, S., 1995, "Alternative Scour Countermeasures," *Proceedings ASCE 1st International Conference Water Resources Engineering*, Vol. 2, 14-18 August 1995, San Antonio, TX, pp. 1819-1823.

Keeley, J.W., 1971, "Bank Protection and River Control in Oklahoma," *Federal Highway Administration*, Washington, D.C.

Kellerhals, R. and Bray, D., 1971, "Sampling Procedures for Coarse Fluvial Sediments," *Proc. Am. Soc. Civ. Engrs., J. Hyd. Div.*, 97(HY7).

Kerenyi, K., Jones, J.S., and Stein, S., 2003, "Bottomless Culvert Scour Study: Phase I Laboratory Report," *Federal Highway Administration*, Report No. FHWA-RD-02-078.

Kerenyi, K., Jones, J.S., and Stein, S., 2007, "Bottomless Culvert Scour Study: Phase II Laboratory Report," *Federal Highway Administration*, Report No. FHWA-HRT-07-026.

Koerner, R.M., 1998, "Designing with Geosynthetics," 4th Edition, Prentice-Hall, Inc., Englewood Cliffs, NJ, 761 p.

Lagasse, P.F., Thompson, P.L., and Sabol, S.A., 1995, "Guarding Against Scour," *Civil Engineering*, American Society of Civil Engineers, June, pp. 56-59.

Lagasse, P.F., Richardson, E.V., and Schall, J.D., 1998, "Instrumentation for Monitoring Scour at Bridges," *Transportation Research Record No. 1647*, Highway Facility Design, Transportation Research Board, National Research Council, National Academies of Science, Washington, D.C.

Lagasse, P.F., Schall, J.D., and Richardson, E.V., 2001a, "Stream Stability at Highway Structures," *Hydraulic Engineering Circular 20*, Third Edition, FHWA NHI 01-002, Federal Highway Administration, U.S. Department of Transportation, Washington, D.C.

Lagasse, P.F., Nordin, C.F., Schall, J.D., and Sabol, G.V., 1991, "Scour Monitoring Devices for Bridges," *Third Bridge Engineering Conference*, Transportation Research Record No. 1290, Denver, CO, Transportation Research Board, National Research Council, Washington, D.C., March 10-13, pp. 281-294.

Lagasse, P.F., Richardson, E.V., Schall, J.D., Price, G.R., 1997, "Instrumentation for Measuring Scour at Bridge Piers and Abutments," NCHRP Report 396, Transportation Research Board, National Academies of Science, Washington, D.C.

Lagasse, P.F., Zevenbergen, L.W., Schall, J.D., and Clopper, P.E., 2001b. "Bridge Scour and Stream Instability Countermeasures," Hydraulic Engineering Circular No. 23, Second Edition, Report FHWA NHI -01-003, Federal Highway Administration, Washington, D.C.

Lagasse, P.F., Spitz, W.J., Zevenbergen, L.W., and Zachmann, D.W., 2004, "Handbook for Predicting Stream Meander Migration," NCHRP Report 533, Transportation Research Board, National Academies of Science, Washington, D.C.

Lagasse, P.F., Clopper, P.E., Zevenbergen, L.W., and Ruff, J.F., 2006, "Riprap Design Criteria, Recommended Specifications, and Quality Control," NCHRP Report 568, Transportation Research Board, National Academies of Science, Washington, D.C.

Lagasse, P.F., Clopper, P.E., Zevenbergen, L.W., and Girard, L.G., 2007, "Countermeasures to Protect Bridge Piers from Scour," NCHRP Report 593, Transportation Research Board, National Academies of Science, Washington, D.C.

Landers, M.N. and Trent, R.E., 1991, "National Bridge Scour Data Collection Program," 1991 National Conference, Hydraulics Division, American Society of Civil Engineers, Nashville, TN (July 29-August 2), pp. 221-226.

Lauchlan, C.S., 1999, "Pier Scour Countermeasures," Ph.D. Thesis, University of Auckland, Auckland, NZ.

Lauchlan, C.S. and Melville, B.W., 2001, "Riprap Protection at Bridge Piers," ASCE Journal of Hydraulic Engineering, Vol. 127, No. 5, pp. 412-418.

Lim, F.H. and Chiew, Y.M., 1996, "Stability of Riprap Layer Under Live-Bed Conditions," In: Maxwell, W.H.C., Preul, H.C., and Stout, G.E. (Eds.), Proceedings Rivertech96: 1st International Conference on New/Emerging Concepts for Rivers, Volume 2, Chicago, IL, pp. 830-837.

Maynard, S.T., 1996, "Toe-Scour Estimation in Stabilized Bendways," ASCE Journal of Hydraulic Engineering, Vol. 122, No. 8, pp. 460-464.

McCullah, J.A. and Gray, D., 2005, "Environmentally Sensitive Channel- and Bank-Protection Measures," NCHRP Report 544, Transportation Research Board, National Academies of Science, Washington, D.C.

MDSHA (Maryland State Highway Agency) 2005, "Office of Bridge Development Manual for Hydrologic and Hydraulic Design, Chapter 11, Evaluating Scour at Bridges, Appendix C, Estimating Scour at Bottomless Arch Culverts, September 2005.

Melville B.W., Ettema, R., and Jain, S.C., 1989, "Measurement of Bridge Scour," Bridge Scour Symposium, Turner-Fairbank Highway Research Center, cosponsored by Federal Highway Administration and Subcommittee of Sedimentation, Interagency Advisory Committee on Water Data, OWDC, USGS, October 17-19, pp. 183-194.

Melville, B.W., Lauchlan, C.S., and Hadfield, A.C., 1997, "Bridge Pier Scour Countermeasures," In: Wang, S.S.Y., Langendoen, E.J., and Shields, F.D., Jr. (Eds.), Proceedings of the Conference on Management of Landscapes Disturbed by Channel Incision: Stabilization, Rehabilitation, Restoration, Oxford, MS.

Molinas, A., 1990, "Bridge Stream Tube Model for Alluvial River Simulation" (BRI-STARS), User's Manual, National Cooperative Highway Research Program, Project No. HR15-11, Transportation Research Board, Washington, D.C.

Morgan, R.P.C., Collins, A.J., Hann, M.J., Morris, J., Dunderdale, J.A.L., and Gowing, D.J.G., 1997, "Waterway Bank Protection: A Guide to Erosion Assessment and Management," Environment Agency, R&D Draft Technical Report W5/i635/3.

Mueller, D.S. and Landers, M.N., 1999, "Portable Instrumentation for Real-Time Measurement of Scour at Bridges," Federal Highway Administration Publication No. FHWA-RD-99-085, Turner-Fairbank Highway Research Center, McLean, VA.

National Transportation Safety Board (NTSB), 1988, "Collapse of the New York Thruway (I-90) Bridge over the Schoharie Creek, Near Amsterdam, New York, April 5, 1987," NTSB/HAR-88/02, NTSB, Washington, D.C.

Pagán-Ortiz, Jorge E., 1991, "Stability of Rock Riprap for Protection at the Toe of Abutments Located at the Floodplain," FHWA Research Report No. FHWA-RD-91-057, U.S. Department of Transportation, Washington, D.C.

Parker, G., Toro-Escobar, C., and Voigt, R.L. Jr., 1998, "Countermeasures to Protect Bridge Piers from Scour," Users Guide (revised 1999) and Final Report, NCHRP Project 24-07, prepared for Transportation Research Board by St. Anthony Falls Laboratory, University of Minnesota, MN, 360 pp.

Parola, A.C., 1993, "Stability of Riprap at Bridge Piers," ASCE, Journal of Hydraulic Engineering, Vol. 119, No. 10, New York, NY, pp. 1080 - 1093.

Pearson, D.R., Jones, J.S., and Stein, S.M., 2000, "Risk-Based Design of Bridge Scour Countermeasures," Fifth International Bridge Engineering Conference, Transportation Research Record 1696, Paper No. 560056, Transportation Research Board, National Research Council, Washington, D.C.

Racin, J.A., Hoover, T.P., and Crossett-Avila, C.M., 2000, "California Bank and Shore Rock Slope Protection Design," Final Report No. FHWA-CA-TL-95-10, Caltrans Study No. F90TL03 (Third Edition - Internet), California Department of Transportation, Sacramento, CA.

Resource Consultants & Engineers (RCE), 1994, "Sediment and Erosion Design Guide," prepared for Albuquerque Metro Arroyo and Flood Control Authority (AMAFCA), Albuquerque, NM.

Richardson, E.V. and Simons, D.B. 1984, "Use of Spurs and Guidebanks for Highway Crossings," Transportation Research Board, Vol. 950, No. 2, Transportation Board, Washington, D.C., pp. 184-193.

Richardson, E.V. and Davis, S.R., 2001, "Evaluating Scour at Bridges," Hydraulic Engineering Circular 18, Fourth Edition, FHWA NHI 01-001, Federal Highway Administration, U.S. Department of Transportation, Washington, D.C.

Richardson, E.V., Simons, D.B., and Lagasse, P.F., 2001, "River Engineering for Highway Encroachments - Highways in the River Environment," Report No. FHWA NHI 01-004, Hydraulic Design Series No. 6, Federal Highway Administration, Washington, D.C.

Richardson, E.V., Lagasse, P.F., Schall, J.D., Ruff, J.F., Brisbane, T.E., and Frick, D.M., 1987, "Hydraulic, Erosion and Channel Stability Analysis of the Schoharie Creek Bridge Failure, New York," Resource Consultants, Inc. and Colorado State University, Fort Collins, CO.

Ruff, J.F. and Fotherby, L.M., 1995, "Bridge Scour Protection System Using Toskanes - Phase 1," Final Report Research Project 91-02, Prepared for Pennsylvania Department of Transportation.

Schall, J.D. and Price, G.R., 2004, "Portable Scour Monitoring Equipment," NCHRP Report 515, Transportation Research Board, National Academies of Science, Washington, D.C.

Schall, J.D., Price, G.R., Fisher, G.A., Lagasse, P.F., and Richardson, E.V., 1997a, "Magnetic Sliding Collar Scour Monitor-Installation, Operation, and Fabrication Manual," NCHRP Report 397B, Transportation Research Board, National Research Council, National Academy Press, Washington, D.C.

Schall, J.D., Price, G.R., Fisher, G.A., Lagasse, P.F., and Richardson, E.V., 1997b, "Sonar Scour Monitor-Installation, Operation, and Fabrication Manual," NCHRP Report 397A, Transportation Research Board, National Research Council, National Academy Press, Washington, D.C.

Schiechtl, H.M. and Stern, R., 1997, "Water Bioengineering Techniques for Water Course, Bank and Shoreline Protection," Blackwell Science, Inc., Cambridge, MA.

Sharp, J.J., 1981, "Hydraulic Modeling," Butterworth & Co., United Kingdom.

Shen, H.W., 1979, "Modeling of Rivers," John Wiley & Sons, NY.

Shields, F.D., Cooper, C.M., and Testa, S., 1995, "Towards Greener Riprap: Environmental Microscale to Macroscale," In: *River, Coastal, and Shoreline Protection: Erosion Control Using Riprap and Armourstone*, C.R. Thorne, S.R. Abt, F.B.J. Barends, S.T. Maynard, and K.W. Pilarczyk (Eds.), Wiley, New York, pp. 557-574.

Simon, A. and Collison, A.J.C., 2002, "Quantifying the mechanical and hydrologic effects of riparian vegetation on streambank stability," *Earth Surface Processes and Landforms* 27(5): 527-546.

Sotir, R.B. and Nunnally, N.R., 1995, "Use of Riprap in Soil Bioengineering Streambank Protection," In: *River, Coastal and Shoreline Protection: Erosion Control Using Riprap and Armourstone*, C.R. Thorne, S.R. Abt, F.B.J. Barends, S.T. Maynard, and K.W. Pilarczyk (Eds.), Wiley, New York.

Stein, S., Jones, J.S., Bertoldi, D., and Umbrell, E., 1998, "Alternatives to Riprap as a Scour Countermeasure," In: Richardson, E.V., and Lagasse, P.F. (Eds.), Stream Stability and Scour at Highway Bridges, Compendium of Papers ASCE Water Resources Engineering Conferences 1991 to 1998, pp. 893-904.

Thorne, C.R. and Abt, S.R., 1993, "Velocity and Scour Prediction in River Bends," Contract Rep. HL-93-1, U.S. Army Engrs., Waterways Experiment Station, Vicksburg, MS.

Thornton, C.I., Watson, C.C., and Abt, S.R., 1999, "Flume Testing of A-Jacks Protection Units," ASCE-EWRI 1999 International Water Resources Engineering Conference, Seattle, WA.

Transportation Research Board (TRB), 1999, "1998 Scanning Review of European Practice for Bridge Scour and Stream Instability Countermeasures," National Cooperative Highway Research Program, Research Results Digest, Number 241, Washington, D.C.

U.S. Army Corps of Engineers, 1981, "The Streambank Erosion Control Evaluation and Demonstration Act of 1974," Final Report to Congress, Executive Summary and Conclusions.

U.S. Army Corps of Engineers, 1991, "Hydraulic Design of Flood Control Channels," EM 1110-2-1601, Department of the Army, Washington, D.C.

U.S. Army Corps of Engineers, 1993, "Scour and Deposition in Rivers and Reservoirs," User's Manual, HEC-6, Hydrologic Engineering Center, Davis, CA.

U.S. Army Corps of Engineers, 1995, "Construction Quality Management," Engineering Regulation No. 1180-1-6, Washington, D.C.

U.S. Army Engineers Waterways Experiment Station (WES), 1998, "Streambank Stabilization Handbook," Veri-Tech, Inc., Vicksburg, MS.

USACE and FHWA, 1997, "Agreement for the Implementation of Scour Countermeasures to Protect Foundations of Scour Critical Bridges," Memorandum, Washington, D.C., February.

U.S. Department of Transportation, Federal Highway Administration, 1988, "Scour at Bridges," Technical Advisory T5140.20, updated by Technical Advisory T5140.23, October 28, 1991, "Evaluating Scour at Bridges," U.S. Department of Transportation, Washington, D.C.

U.S. Department of Transportation, Federal Highway Administration, 2004, "National Bridge Inspection Standards," Federal Register, Volume 69, No. 239, 23CFR Part 650, FHWA Docket No. FHWA-2001-8954, Final Rule, December 14, 2004, effective January 13, 2005, Washington, D.C.

Washington Dept. of Fish & Wildlife, 2003, "Integrated Streambank Protection Guidelines," published in co-operation with Washington Dept. of Transportation and Washington Dept. of Ecology.

Water Engineering & Technology, Inc. (WET), 1990, "Re-evaluation of the Streambank Erosion Control Evaluation and Demonstration Project," Report to U.S. Army Corps of Engineers, Vicksburg District, Contract No. DACW38-88-D-0099.

Waters, C.R., 1994, "The HR Wallingford Scour Monitoring System," Centenary Year Bridge Conference, Cardiff, United Kingdom, September 26-30, pp. 323-328.

Whitlow, T.H. and Harris, R.W., 1979, "Flood Tolerance in Plants: A State-of-the-Art Review," Technical Report E-79-2, U.S. Army Engineer Waterways Experiment Station, Vicksburg, MS.

Wolman, M.G., 1954, "A Method of Sampling Coarse Bed Material," American Geophysical Union, Transactions, 35: pp. 951-956.

Zabilansky, L.J., 1996, "Ice Force and Scour Instrumentation for the White River, Vermont," *U.S. Army Corps of Engineers, Special Report 96-6*, Cold Regions Research & Engineering Laboratory, Hanover, NH, April, 53 pp.

Zabilansky, L.J., 2002, "Ice Cover Effects on Bed Scour: Case Studies," *Proceedings from the 11th ASCE Cold Regions Engineering, Anchorage, AK.*



APPENDICES

APPENDIX A
METRIC SYSTEM, CONVERSION FACTORS, AND WATER PROPERTIES

(page intentionally left blank)

APPENDIX A

Metric System, Conversion Factors, and Water Properties

The following information is summarized from the Federal Highway Administration, National Highway Institute (NHI) Course No. 12301, "Metric (SI) Training for Highway Agencies." For additional information, refer to the Participant Notebook for NHI Course No. 12301.

In SI there are seven base units, many derived units and two supplemental units (Table A.1). Base units uniquely describe a property requiring measurement. One of the most common units in civil engineering is length, with a base unit of meters in SI. Decimal multiples of meter include the kilometer (1000m), the centimeter (1m/100) and the millimeter (1 m/1000). The second base unit relevant to highway applications is the kilogram, a measure of mass which is the inertial of an object. There is a subtle difference between mass and weight. In SI, mass is a base unit, while weight is a derived quantity related to mass and the acceleration of gravity, sometimes referred to as the force of gravity. In SI the unit of mass is the kilogram and the unit of weight/force is the newton. Table A.2 illustrates the relationship of mass and weight. The unit of time is the same in SI as in the English system (seconds). The measurement of temperature is Centigrade. The following equation converts Fahrenheit temperatures to Centigrade, $^{\circ}\text{C} = 5/9 (^{\circ}\text{F} - 32)$.

Derived units are formed by combining base units to express other characteristics. Common derived units in highway drainage engineering include area, volume, velocity, and density. Some derived units have special names (Table A.3).

Table A.4 provides useful conversion factors from English to SI units. The symbols used in this table for metric units, including the use of upper and lower case (e.g., kilometer is "km" and a newton is "N") are the standards that should be followed. Table A.5 provides the standard SI prefixes and their definitions.

Table A.6 provides physical properties of water at atmospheric pressure in SI system of units. Table A.7 gives the sediment grade scale and Table A.8 gives some common equivalent hydraulic units.

Table A.1. Overview of SI Units.		
	Units	Symbol
Base units		
length	meter	m
mass	kilogram	kg
time	second	s
temperature*	kelvin	K
electrical current	ampere	A
luminous intensity	candela	cd
amount of material	mole	mol
Derived units		
Supplementary units		
angles in the plane	radian	rad
solid angles	steradian	sr
*Use degrees Celsius ($^{\circ}\text{C}$), which has a more common usage than kelvin.		

Table A.2. Relationship of Mass and Weight.			
	Mass	Weight or Force of Gravity	Force
English	slug pound-mass	pound pound-force	pound pound-force
metric	kilogram	newton	newton

Table A.3. Derived Units With Special Names.			
Quantity	Name	Symbol	Expression
Frequency	hertz	Hz	s^{-1}
Force	newton	N	$kg \cdot m/s^2$
Pressure, stress	pascal	Pa	N/m^2
Energy, work, quantity of heat	joule	J	$N \cdot m$
Power, radiant flux	watt	W	J/s
Electric charge, quantity	coulomb	C	$A \cdot s$
Electric potential	volt	V	W/A
Capacitance	farad	F	C/V
Electric resistance	ohm	Ω	V/A
Electric conductance	siemens	S	A/V
Magnetic flux	weber	Wb	$V \cdot s$
Magnetic flux density	tesla	T	Wb/m^2
Inductance	henry	H	Wb/A
Luminous flux	lumen	lm	$cd \cdot sr$
Illuminance	lux	lx	lm/m^2

Table A.4. Useful Conversion Factors.

Quantity	From English Units	To Metric Units	Multiplied By*
Length	mile	km	1.609
	yard	m	0.9144
	foot	m	<u>0.3048</u>
	inch	mm	<u>25.40</u>
Area	square mile	km ²	2.590
	acre	m ²	4047
	acre	hectare	0.4047
	square yard	m ²	0.8361
	square foot	m ²	0.09290
square inch	mm ²	645.2	
Volume	acre foot	m ³	1233
	cubic yard	m ³	0.7646
	cubic foot	m ³	0.02832
	cubic foot	L (1000 cm ³)	28.32
	100 board feet	m ³	0.2360
	gallon	L (1000 cm ³)	3.785
cubic inch	cm ³	16.39	
Mass	lb	kg	0.4536
	kip (1000 lb)	metric ton (1000 kg)	0.4536
Mass/unit length	plf	kg/m	1.488
Mass/unit area	psf	kg/m ²	4.882
Mass density	pcf	kg/m ³	16.02
Force	lb	N	4.448
	kip	kN	4.448
Force/unit length	plf	N/m	14.59
	klf	kN/m	14.59
Pressure, stress, modulus of elasticity	psf	Pa	47.88
	ksf	kPa	47.88
	psi	kPa	6.895
	ksi	MPa	6.895
Bending moment, torque, moment of force	ft-lb	N · m	1.356
	ft-kip	kN · m	1.356
Moment of mass	lb · ft	m	0.1383
Moment of inertia	lb · ft ²	kg · m ²	0.04214
Second moment of area	in ⁴	mm ⁴	416200
Section modulus	in ³	mm ³	16390
Power	ton (refrig)	kW	3.517
	Btu/s	kW	1.054
	hp (electric)	W	745.7
	Btu/h	W	0.2931

*4 significant figures; underline denotes exact conversion

Table A.4. Useful Conversion Factors (continued).			
Quantity	From English Units	To Metric Units	Multiplied by*
Volume rate of flow	ft ³ /s	m ³ /s	0.02832
	cfm	m ³ /s	0.0004719
	cfm	L/s	0.4719
	mgd	m ³ /s	0.0438
Velocity, speed	ft/s	m/s	<u>0.3048</u>
Acceleration	f/s ²	m/s ²	<u>0.3048</u>
Momentum	lb · ft/sec	kg · m/s	0.1383
Angular momentum	lb · ft ² /s	kg · m ² /s	0.04214
Plane angle	degree	rad	0.01745
		mrاد	17.45
*4 significant figures; underline denotes exact conversion			

Table A.5. Prefixes.					
Submultiples			Multiples		
deci	10 ⁻¹	d	deka	10 ¹	da
centi	10 ⁻²	c	hecto	10 ²	h
milli	10 ⁻³	m	kilo	10 ³	k
micro	10 ⁻⁶	μ	mega	10 ⁶	M
nano	10 ⁻⁹	n	giga	10 ⁹	G
pica	10 ⁻¹²	p	tera	10 ¹²	T
femto	10 ⁻¹⁵	f	peta	10 ¹⁵	P
atto	10 ⁻¹⁸	a	exa	10 ¹⁸	E
zepto	10 ⁻²¹	z	zetta	10 ²¹	Z
yocto	10 ⁻²⁴	y	yotta	10 ²⁴	Y

Table A.6. Physical Properties of Water at Atmospheric Pressure in SI Units.									
Temperature		Density	Specific Weight	Dynamic Viscosity	Kinematic Viscosity	Vapor Pressure	Surface Tension ¹	Bulk Modulus	
Centigrade	Fahrenheit	kg/m ³	N/m ³	N · s/m ²	m ² /s	N/m ² abs.	N/m	GN/m ²	
0°	32°	1,000	9,810	1.79 x 10 ⁻³	1.79 x 10 ⁻⁶	611	0.0756	1.99	
5°	41°	1,000	9,810	1.51 x 10 ⁻³	1.51 x 10 ⁻⁶	872	0.0749	2.05	
10°	50°	1,000	9,810	1.31 x 10 ⁻³	1.31 x 10 ⁻⁶	1,230	0.0742	2.11	
15°	59°	999	9,800	1.14 x 10 ⁻³	1.14 x 10 ⁻⁶	1,700	0.0735	2.16	
20°	68°	998	9,790	1.00 x 10 ⁻³	1.00 x 10 ⁻⁶	2,340	0.0728	2.20	
25°	77°	997	9,781	8.91 x 10 ⁻⁴	8.94 x 10 ⁻⁷	3,170	0.0720	2.23	
30°	86°	996	9,771	7.97 x 10 ⁻⁴	8.00 x 10 ⁻⁷	4,250	0.0712	2.25	
35°	95°	994	9,751	7.20 x 10 ⁻⁴	7.24 x 10 ⁻⁷	5,630	0.0704	2.27	
40°	104°	992	9,732	6.53 x 10 ⁻⁴	6.58 x 10 ⁻⁷	7,380	0.0696	2.28	
50°	122°	988	9,693	5.47 x 10 ⁻⁴	5.53 x 10 ⁻⁷	12,300	0.0679		
60°	140°	983	9,643	4.66 x 10 ⁻⁴	4.74 x 10 ⁻⁷	20,000	0.0662		
70°	158°	978	9,594	4.04 x 10 ⁻⁴	4.13 x 10 ⁻⁷	31,200	0.0644		
80°	176°	972	9,535	3.54 x 10 ⁻⁴	3.64 x 10 ⁻⁷	47,400	0.0626		
90°	194°	965	9,467	3.15 x 10 ⁻⁴	3.26 x 10 ⁻⁷	70,100	0.0607		
100°	212°	958	9,398	2.82 x 10 ⁻⁴	2.94 x 10 ⁻⁷	101,300	0.0589		

¹Surface tension of water in contact with air

Temperature		Density	Specific Weight	Dynamic Viscosity	Kinematic Viscosity	Vapor Pressure	Surface Tension ¹	Bulk Modulus
Fahrenheit	Centigrade	Slugs/ft ³	Weight lb/ft ³	lb-sec/ft ²	ft ² /sec	lb/in ²	lb/ft	lb/in ²
32	0	1.940	62.416	0.374 X 10 ⁻⁴	1.93 X 10 ⁻⁵	0.09	0.00518	287,000
39.2	4.0	1.940	62.424					
40	4.4	1.940	62.423	0.323	1.67	0.12	.00514	296,000
50	10.0	1.940	62.408	0.273	1.41	0.18	.00508	305,000
60	15.6	1.939	62.366	0.235	1.21	0.26	.00504	313,000
70	21.1	1.936	62.300	0.205	1.06	0.36	.00497	319,000
80	26.7	1.934	62.217	0.180	0.929	0.51	.00492	325,000
90	32.2	1.931	62.118	0.160	0.828	0.70	.00486	329,000
100	37.8	1.927	61.998	0.143	0.741	0.95	.00479	331,000
120	48.9	1.918	61.719	0.117	0.610	1.69	.00466	332,000
140	60.0	1.908	61.386	0.0979	0.513	2.89		
160	71.1	1.896	61.006	0.0835	0.440	4.74		
180	82.2	1.883	60.586	0.0726	0.385	7.51		
200	93.3	1.869	60.135	0.0637	0.341	11.52		
212	100	1.847	59.843	0.0593	0.319	14.70		

¹Surface tension of water in contact with air

Table A.8. Sediment Particles Grade Scale.									
Size						Approximate Sieve Mesh Openings Per Inch		Class	
Millimeters	Microns	Inches	Tyler	U.S. Standard					
4000-2000	-----	160-80	----	-----					Very large boulders
2000-1000	-----	80-40	----	-----					Large boulders
1000-500	-----	40-20	----	-----					Medium boulders
500-250	-----	20-10	----	-----					Small boulders
250-130	-----	10-5	----	-----					Large cobbles
130-64	-----	5-2.5	----	-----					Small cobbles
64-32	-----	2.5-1.3	----	-----					Very coarse gravel
32-16	-----	1.3-0.6	----	-----					Coarse gravel
16-8	-----	0.6-0.3	2 1/2	-----					Medium gravel
8-4	-----	0.3-0.16	5	-----					Fine gravel
4-2	-----	0.16-0.08	9	-----					Very fine gravel
2-1	2.00-1.00	-----	16	-----					Very coarse sand
1-1/2	1.00-0.50	-----	32	-----					Coarse sand
1/2-1/4	0.50-0.25	-----	60	-----					Medium sand
1/4-1/8	0.25-0.125	-----	115	-----					Fine sand
1/8-1/16	0.125-0.062	-----	250	-----					Very fine sand
1/16-1/32	0.062-0.031	-----	-----	-----					Coarse silt
1/32-1/64	0.031-0.016	-----	-----	-----					Medium silt
1/64-1/128	0.016-0.008	-----	-----	-----					Fine silt
1/128-1/256	0.008-0.004	-----	-----	-----					Very fine silt
1/256-1/512	0.004-0.0020	-----	-----	-----					Coarse clay
1/512-1/1024	0.0020-0.0010	-----	-----	-----					Medium clay
1/1024-1/2048	0.0010-0.0005	-----	-----	-----					Fine clay
1/2048-1/4096	0.0005-0.0002	0.5-0.24	-----	-----					Very fine clay

Table A.9. Common Equivalent Hydraulic Units.

Volume										
Unit	Equivalent									
	cubic inch	liter	u.s. gallon	cubic foot	cubic yard	cubic meter	acre-foot	sec-foot-day		
liter	61.02	1	0.264 2	0.035 31	0.001 308	0.001	810.6 E - 9	408.7 E - 9		
U.S. gallon	231.0	3.785	1	0.133 7	0.004 951	0.003 785	3.068 E - 6	1.547 E - 6		
cubic foot	1728	28.32	7.481	1	0.037 04	0.028 32	22.96 E - 6	11.57 E - 6		
cubic yard	46 660	764.6	202.0	27	1	0.746 6	619.8 E - 6	312.5 E - 6		
meter ³	61 020	1000	264.2	35.31	1.308	1	810.6 E - 6	408.7 E - 6		
acre-foot	75.27 E + 6	1 233 000	325 900	43 560	1 613	1 233	1	0.504 2		
sec-foot-day	149.3 E + 6	2 447 000	646 400	86 400	3 200	2 447	1.983	1		
Discharge (Flow Rate, Volume/Time)										
Unit	Equivalent									
	gallon/minute	liter/second	gallon/min	liter/sec	acre-foot/day	foot ³ /sec	million gal/day	meter ³ /sec		
gallon/minute			1	0.063 09	0.004 419	0.002 228	0.001 440	63.09 E - 6		
liter/second			15.85	1	0.070 05	0.035 31	0.022 82	0.001		
acre-foot/day			226.3	14.28	1	0.504 2	0.325 9	0.014 28		
feet ³ /second			448.8	28.32	1.983	1	0.646 3	0.028 32		
million gal/day			694.4	43.81	3.068	1.547	1	0.043 82		
meter ³ /second			15 850	1000	70.04	35.31	22.82	1		

(page intentionally left blank)

APPENDIX B
STANDARD TEMPLATE FOR A PLAN OF ACTION

STANDARD TEMPLATE FOR A PLAN OF ACTION

B.1 Overview

In order to facilitate the development of a POA, the FHWA has created a "standard" template for bridges that are scour critical. This template includes the minimum information recommended by FHWA for a POA.

The template is intended to be a guide and tool for bridge owners to use in developing their POAs. The template provides the program manager with a summary of the type of information required to develop a plan of action for bridges that are scour critical or have unknown foundations.

All the fields in the template may be modified so that local terminology is employed, unique information may be added regarding local and site-specific scour and stream stability concerns, and local sources of information may be included. The electronic Microsoft Word document template may be downloaded from the FHWA website:

<http://www.fhwa.dot.gov/engineering/hydraulics/bridgehyd/poa.cfm>

Blocks in this template will expand automatically to allow additional space. Where check boxes are provided, they can be checked by double-clicking on the box and selecting the "checked" option.

To provide guidance and training on preparation of a POA for scour critical bridges, the FHWA National Highway Institute has prepared an on-line module (NHI Course No. 135085) which includes the suggested template for a POA and illustrates its application to field case studies. This training module can be accessed (see site reference, p. 2.6).

A state's Bridge Management System is a useful source of data for developing a POA. Many DOT's are now using information technology (IT) systems that provide immediate access via the bridge engineer's desktop computer to an integrated system of bridge management information and data bases. Much of the information outlined in the template may be obtained from these systems.

B.2 Executive Summary

The standard template contains ten sections. Sections 1 through 4 are intended as an executive summary for the busy reviewer/manager who may not need the details of Sections 5 through 10, and show:

- Section 1: General information
- Section 2: Who prepared the POA
- Section 3: The source of the problem
- Section 4: What actions are recommended and their status

To assist in completing a POA using the template, the remaining sections of this appendix contain general guidance for each section of the template. Note that an abbreviated set of instructions is appended to the template.

B.3 Standard Template Sections

Section 1 – General Information

Section 1 of the POA Standard Template covers general information about the bridge. This information is usually available from the bridge owner's Bridge Management System or bridge-specific files.

The bridge replacement information provides a framework for decisions regarding the need for a structural or hydraulic countermeasure.

The bridge type information provides insight on how the bridge could fail, if significant scour were to occur. For example, a simply-supported span bridge can fail suddenly, so the bridge should be closed as soon as scour becomes close to critical. Bridges with structural redundancy may allow more time to respond to an emergency situation.

Also, identified in this section is whether the bridge provides service to emergency facilities or is part of an evacuation route. This information is important in bridge closure plans, since early communication of a bridge closure to emergency responders could help them effectively detour their normal routes.

Section 2 – Responsibility for POA

Section 2 of the POA Standard Template provides information on who are the people responsible for preparing and maintaining the POA.

- *Author or Authors* refers to the individual or company that developed the POA, such as the State Bridge Maintenance Engineer or a consultant.

Concurrences on POA refers to the individuals or organizations which must concur with the contents of the POA. The individuals or organizations may also refer to upper management who approve funding or county officials and law enforcement agencies who must agree with the bridge closure plans and the disruption the closure will have on the public. Gaining concurrence before an emergency occurs helps to minimize inter-agency conflicts during an emergency.

Also, in Section 2 is information on the POA update: who will do the update, when, and what was updated. The POA should be reviewed and updated on a routine basis to ensure that the contents of the plan are still valid.

Section 3 – Scour Vulnerability

Section 3 of the POA Standard Template provides a summary of the scour status of the bridge.

Section 3a shows the **current** scour coding. If *Other* is selected, the appropriate code would be provided. For example, if the foundation is unknown *U* would be entered in the *Other* field.

In Section 3b indicate how the Item 113 code was determined. If the bridge has a *U* code, *unknown* must be written in the *Other* field.

Section 3c, provides space for a narrative description to summarize the information from the scour evaluation. The template has been developed to expand automatically as information is entered. Some items to include are:

- Scour critical flood flow and scour depth
- 100- or 500-year flood flows
- Overtopping flow

Section 3d provides space to summarize the scour history, including when, where and how much scour or stream instability has been observed at the bridge. Also, information on scour countermeasures previously installed at the bridge and their performance should be included.

Section 4 – Recommended Action(s)

Section 4 of the POA Standard Template contains highlights from the recommended actions from Sections 6 and 7 of the template. Items 4a, 4b, and 4c refer to the main parts of the POA monitoring program. Item 4d refers to the hydraulic or structural countermeasure selected in Section 7. This section cannot be completed until Sections 6 and 7 are completed.

Section 5 – NBIS Coding Information

Section 5 of the POA Standard Template contains previous and current codes for the hydraulic related items of the NBI. This information provides a quick indication of observed or potential long-term problems or adverse trends that may affect the stability of the bridge foundations.

The *Inspection Date* corresponds to the date of the inspection when the NBI items were coded. If the Items were coded on a date different than the inspection date, this different date is indicated in the *Comments* block.

For additional details on Items 113 and 60, see the FHWA Policy *Memorandum Revision of Coding Guide, Item 113 – Scour Critical Bridges* dated April 27, 2001.

Section 6 – Monitoring Program

There are three types of countermeasures which should be considered as part of the countermeasure program:

1. Monitoring
2. Hydraulic
3. Structural

A monitoring countermeasure can be considered a key component of a POA, either alone or in combination with other countermeasures. Monitoring is highlighted in its own section, Section 6, in the POA Standard Template. Section 6 is subdivided into three additional subsections including:

- Inspection Frequency
- Fixed Monitoring
- Flood Monitoring

The first subsection of Section 6 covers information on the frequency of inspection. Bridges are usually inspected biennially. Bridge owners may choose to keep this schedule but may also specify inspectors look at certain items at the bridge to ensure stability with regard to scour. In this case, the *Regular Inspection Program* box would be selected along with a list of the items to be watched. These items may include countermeasures, channel bed elevations, signs of movement or settlement.

Some bridge owners may choose to increase the frequency of inspection to less than the 2-year cycle. In this case, the *Increased Inspection Frequency* box would be checked and the number of months between inspections would be indicated. Usually only items pertinent to scour and stream stability would be observed and inspected.

Underwater inspections may also be required at the bridge. If the Underwater Inspection cycle remains on the regular schedule, then the *Underwater Inspection Required* box would be checked. If an increased cycle is needed, then the *Increased Underwater Inspection Frequency* box would be selected and the months between inspections indicated. In both cases the items for inspection and observation are indicated on the POA.

The second subsection of Section 6 covers information on Fixed Monitoring Devices. Fixed monitoring devices can provide continuous information about scour at the bridge site (see Chapter 9). This information can lead to early identification of potential scour problems.

The Fixed Monitoring box would be selected if a bridge owner opts to use fixed monitoring devices at the bridge. The type of devices and location of devices would be described in the plan. Details about the devices may be included in Attachment F to the POA.

In most cases, the fixed monitoring device can send information continuously from the bridge site. However, this amount of information can become cumbersome, so most bridge owners obtain or sample the information periodically. The sampling interval should be indicated on the POA and can be modified during flood events. If modified, the rationale for the change would be noted on the POA.

The information received from the fixed monitoring device should be reviewed for developing scour problems. During normal flow, the information may be reviewed daily, weekly, or monthly. During flood events, the review frequency may increase. The POA should detail the frequency of review and identify who is conducting the review.

Scour Critical Criteria should be determined from a scour evaluation study. This criteria should be indicated on the plan. Selecting an elevation higher than the scour critical elevation ensures sufficient time needed to take action in protecting the traveling public and possibly the bridge. This elevation, called the Scour Alert Criteria, should also be presented on the POA.

The third subsection of Section 6 describes monitoring actions that should be implemented during an actual flood event. If the bridge owner inspects the bridge visually during a flood, then the *Visual Inspection* box is selected. Those individuals visually observing the bridge may look for movement or settlement in the bridge or for a certain elevation of water, which could trigger the actions prescribed in the POA. If some kind of instrumentation is used to measure scour or water elevation, the *Instrument* box is selected and the applicable instrumentation type indicated. Both the *Visual Inspection* and the *Instrument* boxes may be selected.

The POA should document thresholds for the start and end of flood monitoring and note the frequency of the monitoring (see Chapter 2, Section 2.1.4). These thresholds may include:

- Flood discharge
- Stage
- Water surface elevation
- Rainfall data

The POA should clearly describe the thresholds and how the threshold is determined. For example, the threshold discharge or stage may be tied to a nearby USGS gage. Some bridge owners have opted to mark their bridges with the threshold water surface elevations to ensure inspectors know when action should be taken. The POA should also describe the actions required when threshold values are reached.

The agency, department, position, or person responsible for inspecting or reviewing instrumentation data should be listed at the end of Section 6 in the POA Standard Template. Some bridge owners may have maintenance staff rather than bridge inspectors monitor the bridge during a flood and then have bridge inspection staff conduct the post-flood inspection. All staff with responsibilities in implementing the POA should be listed. More than one person may be listed, especially to provide back up points-of-contact.

In some cases, the person at the bridge site during a flood event must confer with someone of greater authority in order to decide to close the bridge. This decision maker should also be listed in Section 6 of the POA Standard Template.

Finally, if action must be taken, the agency, department, position, or person responsible for taking the action would be listed. For example, if the local law enforcement is to close the bridge and set up the detour route, this agency is listed in Section 6 of the POA Standard Template.

Section 7 – Countermeasure Recommendations

Section 7 of the POA Standard Template summarizes the alternative countermeasures considered for the bridge, as well as the final countermeasures selected and rationale (see Chapter 2, Sections 2.3 – 2.5).

If a monitoring countermeasure were selected for the countermeasure program, the *Monitoring* box would be selected. If a structural and/or hydraulic countermeasure were selected, then the *Structural/Hydraulic Scour Countermeasures Considered* box would be selected. Both boxes may be selected, if needed.

Under the *Priority Ranking* and *Estimated Cost* columns, the various countermeasures for consideration along with their corresponding estimated costs. The selected countermeasures are indicated and the reasons for selecting the countermeasures should be explained on the *Basis for selection* line. Supporting information for the considered countermeasures can be included in Attachment F. Sufficient information to help independent reviewers understand the countermeasure selection process and the resulting decisions should be included.

This section also includes boxes for indicating the countermeasure implementation project type.

The last part of Section 7 of the POA Standard Template requires information on agency/department/position/person responsible for designing and implementing the countermeasure program. More than one person may be listed, if appropriate.

Target design and construction dates should also be required.

Section 8 – Bridge Closure Plan

Section 8 of the POA Standard Template provides instructions for closing a bridge. Specifically, this section should include:

- Specific criteria indicating when to close the bridge
- Who should close the bridge
- Contact information, such as management or local law enforcement

Several examples of bridge closing conditions are provided. If the bridge owner has closure instructions specified in another document, these instructions should be referenced on the *Emergency repair plans* line.

The POA should also detail the process for reopening the bridge. In some cases, the bridge may be reopened when the floodwater has receded sufficiently. In other cases, the bridge will require inspection to ensure it is structurally sound. The reopening criteria should be listed. The agency or person who will inspect or make the decision to reopen the bridge should be identified in the plan.

Section 9 – Detour Route

Section 9 of the POA Standard Template describes potential detour routes, if the bridge is closed. The description should include route numbers, from/to locations, distances from closed bridge, as well as any other pertinent information. A map of the detour routes should be provided in Attachment E to the POA.

The bridges on the detour route should be listed in the *Bridges on Detour Route* table, along with restrictive factors for each bridge on the detour route, such as:

- Load restrictions
- Clearance restrictions
- Scour vulnerability condition

Additional items to present in Section 9 include:

- Required traffic control equipment
- Critical issues, such as flood overtopping vulnerability for bridges and roadways along the detour route, waterway adequacy of the detour bridges, and lane restrictions
- Authority to communicate with the media and public

Concurrence from local law enforcement agencies on the proposed detour and the closing procedures should be obtained and copies of the POA provided to these agencies.

Detour routes are not set in stone, but information should be provided on potential detours. Some factors to be considered in documenting in advance a detour route for a particular bridge include:

- Detours must be set up, taking into consideration the conditions existing at the time a detour is needed. For some bridges, it may not be possible to foresee what these conditions might be, which roads might be flooded, which bridges may already be closed, what will be the load and clearance restrictions for the proposed detour route, etc.
- DOT or bridge owner may have a designated department/office which is intimately familiar with their bridges and road systems, and are in the best position to quickly decide upon and coordinate a detour route for the given set of circumstances. This would be noted in the POA.
- Decisions are made on the basis of the conditions that exist at the time of the closure.

Consideration needs to be given to floods that may overtop bridges and approach roadways on the detour route. Actual detour routes should be based on roadway and bridge network status at the time the detour is proposed.

Section 10 – Attachments

Section 10 is the final section of the template and contains the following Attachments.

Attachment A should reference or include all available boring logs, probes, construction inspection and monitoring records, monitoring well readings, test pits, soil laboratory data, and anecdotal information.

Attachment B should reference or include all available channel cross sections for the bridge. Historic cross section comparisons, if available, should also be included.

Attachments C, D, and E are for documenting bridge elevation and plan views, and maps necessary to show detour routes.

Attachment F should include documentation on scour countermeasure alternatives. A comprehensive plan of action should provide enough information that an independent reviewer could arrive at the same conclusion regarding the preferred countermeasure alternative. For proposed scour countermeasures, a conceptual design should be prepared and details including reference to any hydraulic, structural or geotechnical studies that have been completed for the purpose of scour mitigation should be provided. Estimated costs of all proposed scour countermeasures should also be provided.

Details and dates of any recent scour countermeasure that has been implemented to address the current scour critical/unknown foundation status of the bridge should be included. All applicable studies, lead agencies, subcontractors and as-builts should be noted or included in Appendix F.

Attachment G may also reference or include historic and current aerial photographs of the site.

Attachment H may be used for any additional information such as: (1) standard closing and reopening procedures, (2) information on public transit, or (3) special circumstances such as access to emergency facilities, evacuation routes, etc. In some situations, public transportation (e.g., bus routes) may be of importance to the public with respect to detours. If additional information is included, indicate this in Section 10 of the template.

(page intentionally left blank)

SCOUR CRITICAL BRIDGE - PLAN OF ACTION

1. GENERAL INFORMATION

Structure number: _____	City, County, State: _____	Waterway: _____
Structure name: _____	State highway or facility carried: _____	Owner: _____
Year built: _____	Year rebuilt: _____	Bridge replacement plans (if scheduled): _____ Anticipated opening date: _____
Structure type: <input type="checkbox"/> Bridge <input type="checkbox"/> Culvert		
Structure size and description: _____		
Foundations: <input type="checkbox"/> Known, type: _____ Depth: _____ <input type="checkbox"/> Unknown		
Subsurface soil information (check all that apply): <input type="checkbox"/> Non-cohesive <input type="checkbox"/> Cohesive <input type="checkbox"/> Rock		
Bridge ADT: _____	Year/ADT: _____	% Trucks: _____
Does the bridge provide service to emergency facilities and/or an evacuation route (Y/N)? _____		
If so, describe: _____		

2. RESPONSIBILITY FOR POA

Author(s) of POA (name, title, agency/organization, telephone, pager, email): _____
Date: _____

Concurrences on POA (name, title, agency/organization, telephone, pager, email): _____

POA updated by (name, title, agency/organization): _____ Date of update: _____

Items updated: _____

POA to be updated every _____ months by (name, title, agency/organization): _____
Date of next update: _____

3. SCOUR VULNERABILITY

a. Current Item 113 Code: 3 2 1 Other: _____

b. Source of Scour Critical Code: Observed Assessment Calculated Other: _____

c. Scour Evaluation Summary: _____

d. Scour History: _____

4. RECOMMENDED ACTION(S) (see Sections 6 and 7)

	<u>Recommended</u>		<u>Implemented</u>	
a. Increased Inspection Frequency	<input type="checkbox"/> Yes	<input type="checkbox"/> No	<input type="checkbox"/> Yes	<input type="checkbox"/> No
b. Fixed Monitoring Device(s)	<input type="checkbox"/> Yes	<input type="checkbox"/> No	<input type="checkbox"/> Yes	<input type="checkbox"/> No
c. Flood Monitoring Program	<input type="checkbox"/> Yes	<input type="checkbox"/> No	<input type="checkbox"/> Yes	<input type="checkbox"/> No
d. Hydraulic/Structural Countermeasures	<input type="checkbox"/> Yes	<input type="checkbox"/> No	<input type="checkbox"/> Yes	<input type="checkbox"/> No

5. NBIS CODING INFORMATION

	<u>Current</u>	<u>Previous</u>
Inspection date		
Item 113 Scour Critical		
Item 60 Substructure		
Item 61 Channel & Channel Protection		
Item 71 Waterway Adequacy		
Comments: (drift, scour holes, etc. - depict in sketches in Section 10)		

6. MONITORING PROGRAM

- Regular Inspection Program** w/surveyed cross sections
 Items to Watch: _____
- Increased Inspection Frequency of ___ mo.** w/surveyed cross sections
 Items to Watch: _____
- Underwater Inspection Required**
 Items to Watch: _____
- Increased Underwater Inspection Frequency of ___ mo.**
 Items to Watch: _____
- Fixed Monitoring Device(s)**
 Type of Instrument: _____
 Installation location(s): _____
 Sample Interval: 30 min. 1 hr. 6 hrs. 12 hrs. Other: _____
 Frequency of data download and review: Daily Weekly Monthly Other _____
- Scour alert criteria for each pier/abutment: _____
 Scour critical criteria for each pier/abutment _____
 Survey ties: _____
 Criteria for termination of fixed monitoring program: _____
- Flood Monitoring Program**
 Type: Visual inspection
 Instrument (*check all that apply*):
 Portable Geophysical Sonar Other: _____

Flood monitoring required: Yes No
 Flood monitoring event defined by (*check all that apply*):
 Discharge _____ Stage _____
 Elev. measured from _____ Rainfall _____ (in/mm) per _____ (hour)
 Flood forecasting information: _____
 Flood warning system: _____

Frequency of flood monitoring: 1 hr. 3 hrs. 6 hrs. Other: _____

Post-flood monitoring required: No Yes, within _____ days
 Frequency of post-flood monitoring: Daily Weekly Monthly Other: _____
 Criteria for termination of flood monitoring: _____
 Criteria for termination of post-flood monitoring: _____
 Scour alert criteria for each pier/abutment: _____
 Scour critical criteria for each pier/abutment: _____

Note: Additional details for action(s) required may be included in Section 8.

Action(s) required if scour alert criteria detected (*include notification and closure procedures*): _____
 Action(s) required if scour critical criteria detected (*include notification and closure procedures*): _____

Agency and department responsible for monitoring: _____

Contact person (*include name, title, telephone, pager, e-mail*): _____

7. COUNTERMEASURE RECOMMENDATIONS

Prioritize alternatives below. Include information on any hydraulic, structural or monitoring countermeasures.

Monitoring countermeasure (see Section 6 and Section 10 - Attachment F)
 Estimated cost \$ _____

Structural/hydraulic countermeasures (see Section 10 - Attachment F):

<u>Priority Ranking</u>	<u>Estimated cost</u>
(1) _____	_____ \$
(2) _____	_____ \$
(3) _____	_____ \$
(4) _____	_____ \$
(5) _____	_____ \$

Basis for the selection of the preferred scour countermeasure: _____

Countermeasure implementation project type:

- Proposed Construction Project Maintenance Project
 Programmed Construction - Project Lead Agency:
 Bridge Bureau Road Design Other _____

Agency and department responsible for countermeasure program (if different from Section 6 contact for monitoring): _____

Contact person (include name, title, telephone, pager, e-mail): _____

Target design completion date: _____

Target construction completion date: _____

Countermeasures already completed: _____

8. BRIDGE CLOSURE PLAN

Scour monitoring criteria for consideration of bridge closure:

- Water surface elevation reaches _____ at _____
 Overtopping road or structure
 Scour measurement results / Monitoring device (See Section 6)
 Observed structure movement / Settlement
 Discharge: _____ cfs/cms
 Flood forecast: _____
 Other: Debris accumulation Movement of riprap/other armor protection
 Loss of road embankment

Emergency repair plans (include source(s), contact(s), cost, installation directions): _____

Agency and department responsible for closure: _____

Contact persons (name, title, agency/organization, telephone, pager, email): _____

Criteria for re-opening the bridge: _____

Agency and person responsible for re-opening the bridge after inspection: _____

9. DETOUR ROUTE

Detour route description (route number, from/to, distance from bridge, etc.) - Include map in Section 10, Attachment E.

Bridges on Detour Route:

Bridge Number	Waterway	Sufficiency Rating/ Load Limitations	Item 113 Code

Traffic control equipment (detour signing and barriers) and location(s): _____			
Additional considerations or critical issues (susceptibility to overtopping, limited waterway adequacy, lane restrictions, etc.): _____			
News release, other public notice (include authorized person(s), information to be provided and limitations): _____			
10. ATTACHMENTS			
Please indicate which materials are being submitted with this POA:			
<input type="checkbox"/> Attachment A: Boring logs and/or other subsurface information			
<input type="checkbox"/> Attachment B: Cross sections from current and previous inspection reports			
<input type="checkbox"/> Attachment C: Bridge elevation showing existing streambed, foundation depth(s) and observed and/or calculated scour depths			
<input type="checkbox"/> Attachment D: Plan view showing location of scour holes, debris, etc.			
<input type="checkbox"/> Attachment E: Map showing detour route(s)			
<input type="checkbox"/> Attachment F: Supporting documentation, calculations, estimates and conceptual designs for scour countermeasures.			
<input type="checkbox"/> Attachment G: Photos			
<input type="checkbox"/> Attachment H: Other information: _____			

INSTRUCTIONS FOR COMPLETING THE PLAN OF ACTION

The existing bridge management system in your state will provide much of the information required to fill out this template. Note that all blocks in this template will expand automatically to allow as much space as you require. All fields can be modified to accommodate local terminology, as desired. Where check boxes are provided, they can be checked by double-clicking on the box and selecting the “checked” option. If you include additional attachments, please indicate this in Section 10.

Section 1

Foundations – It is recommended that substructure depths be shown in the bridge elevation, Attachment C (see Section 10). The minimum depth should be reported in Section 1 as a worst-case condition.

Subsurface soil information – If conditions vary with depth and/or between substructure units, this should be noted and included in Attachments A and/or C (see Section 10).

Sections 1, 2, 3, and 4

These sections are intended as an executive summary for the reviewer/manager who may not need the details of Sections 5 through 10, and show:

Section 1: General information

Section 2: Who prepared the POA

Section 3: The source of the problem

Section 4: What actions are recommended and their status

Section 3

Reasons why the bridge has been coded scour critical for Item 113:

Scour Critical

- Aggressive stream or tidal waterway (high velocity, steep slope, deep flow)
- Actively degrading channel
- Bed material is easily eroded
- Large angle of attack ($> 10^\circ$)
- Significant overbank or floodplain flow (floodplain >50 m or 150 ft wide)
- Possibility of bridge overtopping (potential for pressure flow through bridge)
- Evidence of scour and/or degradation
- Evidence of structural damage due to scour
- Foundations are spread footings on erodible soil, shallow piles, or embedment unknown
- Exposed footing in erodible material
- Exposed piles with unknown or insufficient embedment
- Loss of abutment and/or pier protection
- No countermeasures or countermeasures in poor condition
- Needs countermeasures immediately

Unknown Foundations

- No record of foundation type (spread footing vs. piles)
- Depth of foundation or pile embedment unknown
- Condition of foundation or pile embedment unknown
- Subsurface soil strata not documented

Section 5

This section highlights recent changes in the scour/hydraulics coding items as an indication of potential problems or adverse trends. See FHWA Policy Memorandum on Revision of Coding Guide, Item 113 – Scour Critical Bridges dated April 27, 2001 for details on Items 113 and 60. A link to this memorandum is provided below:

(www.fhwa.dot.gov/engineering/hydraulics/policymemo/revguide.cfm).

Section 6

Multiple individuals responsible for various monitoring activities may be listed, as appropriate.

Section 7

Guidance on the selection and design of scour countermeasures may be found in FHWA Hydraulic Engineering Circular No. 23, *Bridge Scour and Stream Instability Countermeasures*, Third Edition, 2009. To facilitate the selection of alternative scour countermeasures, a matrix describing the various countermeasures and their attributes is presented in this circular. A link to this document is provided below:

<http://isddc.dot.gov/OLPFiles/FHWA/010592.pdf>

Section 8

Standard closure and reopening procedures, if available, may be appended to the POA (see Section 10, Attachment H).

Section 9

In some situations, public transportation (e.g., bus routes) may be of importance to the public, and therefore could be included in the POA (see Section 10, Attachment H).

(page intentionally left blank)

APPENDIX C

PIER SCOUR COUNTERMEASURE SELECTION METHODOLOGY

(page intentionally left blank)

PIER SCOUR COUNTERMEASURE SELECTION METHODOLOGY

C.1 Overview

This selection methodology provides a quantitative assessment of the suitability of six armor-type countermeasures for pier scour based on selection factors that consider river environment, construction considerations, maintenance, performance, and estimated life-cycle cost (Lagasse et al. 2007). With the exception of life-cycle costs, the methodology analyzes the design factors by stepping the user through a series of decision branches, ultimately resulting in a site-specific numerical rating for each selection factor (see Section 3.2.5). The following countermeasures are evaluated by this methodology:

- Standard (loose) riprap
- Partially grouted riprap
- Articulating concrete blocks
- Gabion mattresses
- Grout-filled mattresses
- Grout-filled bags

To facilitate the decision-making process, the procedure was automated using a Microsoft® Excel spreadsheet format. In the spreadsheet, the decision-making process can easily be modified to consider new situations or include additional information. Detailed directions are included in the program file, and automated features are incorporated in the program to step the user through the process.

C.2 Selection Index

Five factors are used to compute a Selection Index (SI) for each countermeasure:

- S1: Bed Material size and transport
- S2: Severity of debris or ice loading
- S3: Constructability constraints
- S4: Inspection and maintenance requirements
- LCC: Life-cycle costs

The selection Index is calculated as:

$$SI = (S1 \times S2 \times S3 \times S4) / LCC \quad (C.1)$$

The countermeasure that has the highest value of SI is considered to be most appropriate for a given site, based not only on its suitability to the specific riverine and project site conditions, but also in consideration of its economy. The approach is sensitive to assumptions regarding initial construction cost, remaining service life, assumed frequency of maintenance events, and extent of maintenance required. Each of these factors requires experience and engineering judgment, as well as site- or region-specific information on the cost of materials and delivery, construction practices, and prevailing labor rates. *It should be noted that the methodology can be used simply to rank the countermeasures in terms of suitability alone by assuming that the life-cycle costs are the same for all countermeasures.*

In Section 3.2.5 the five factors that compose the methodology are described in detail. Flow charts illustrating selection factors S1 through S4 and reference to Excel spread sheet support follows.

C.3 Additional Considerations and Support

Federal or state regulations that preclude and use of a particular countermeasure because of environmental considerations and permitting issues are beyond the scope of NCHRP Project 24-07(2). The practitioner in any particular state must be aware of circumstances that may warrant the exclusion of a countermeasure for consideration at a specific site.

A feature allowing the user to easily include an additional design consideration, such as state-specific environmental concerns, to the computation of the Selection Index was added to the Excel-based selection methodology program. Inclusion of an additional selection criterion will require the user to assign values in the context of the selection factors for all countermeasures considered.

In addition, a feature was added to the selection methodology Excel spreadsheet capability to permit a user to introduce another countermeasure and generate selection factor values for that countermeasure. Inclusion of an additional countermeasure will require the user to assign values in the context of the design considerations and selection factors. The supplementary countermeasure feature and design consideration feature can be used independently or together, as described in the countermeasure selection Excel file available on the TRB website (http://trb.org/news/blurb_detail.asp?id=7998).

Factor S1: Bed Material

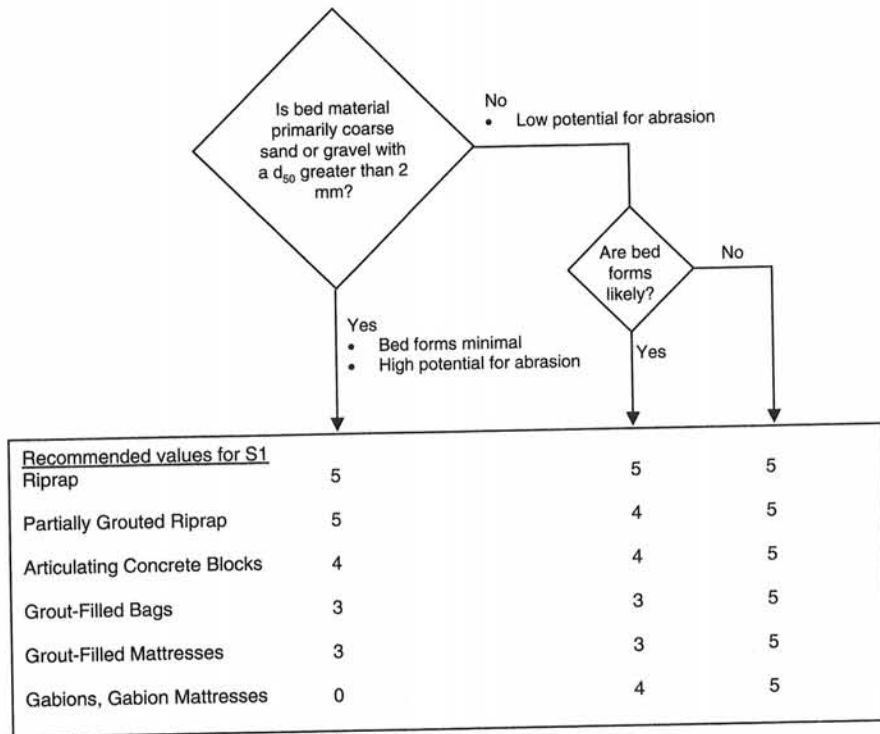

Factor S2: Ice/Debris Load

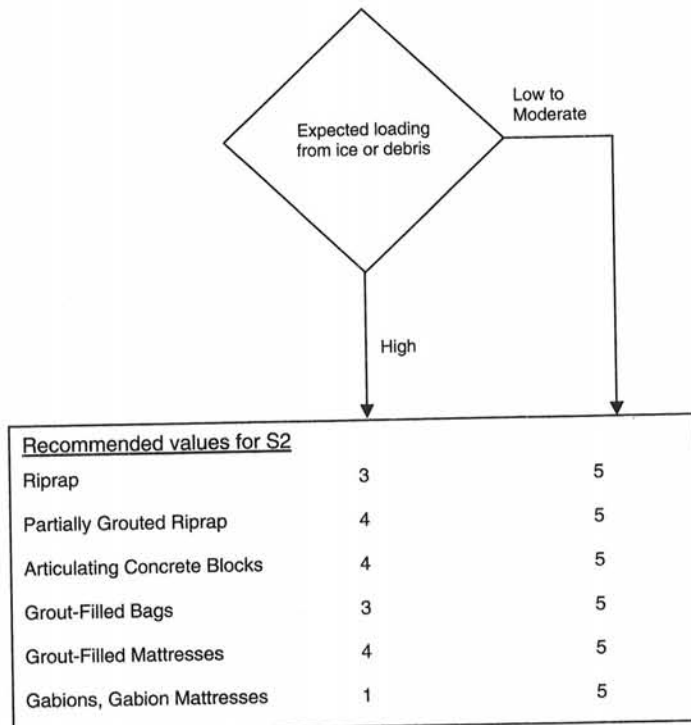

Factor S3: Construction Considerations

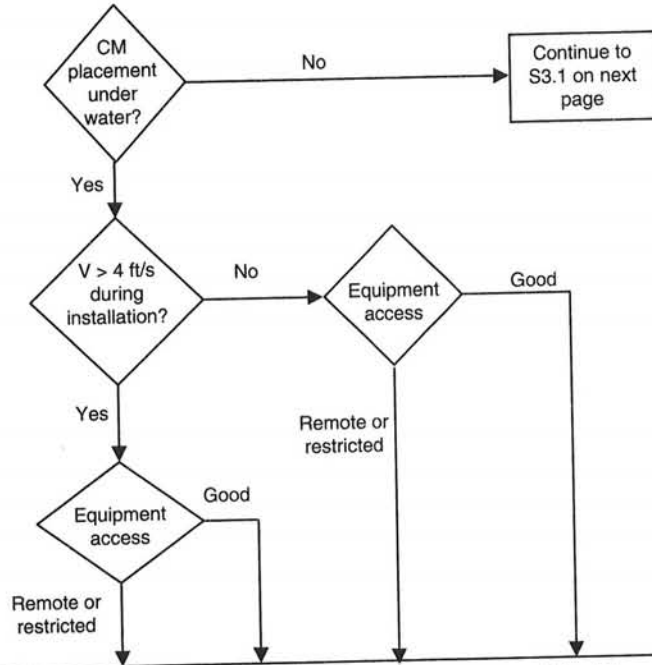

<u>Recommended values for S3</u>	<u>SF</u>	<u>DF</u>	<u>SF</u>	<u>DF</u>	<u>SF</u>	<u>DF</u>	<u>SF</u>	<u>DF</u>
Riprap	0	2	1	5	1	3	2	5
Partially Grouted Riprap	0	0	0	0	2	4	0	5
Articulating Concrete Blocks	0	0	1	1	2	2	0	4
Grout-Filled Bags	0	1	1	2	1	3	1	5
Grout-Filled Mattresses	0	0	0	0	3	3	0	4
Gabions, Gabion Mattresses	0	0	0	1	1	1	0	3

*Note: Armoring countermeasures not recommended for these conditions.

SF = Shallow Pier, e.g. Spread Footing DF = Deep Footing

Factor S3.1: Construction Considerations

No Underwater Placement

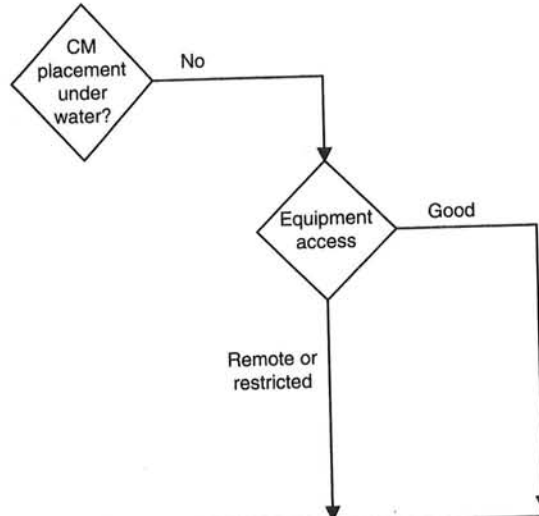

<u>Recommended values for S3</u>	<u>SF</u>	<u>DF</u>	<u>SF</u>	<u>DF</u>
Riprap	1	3	1	5
Partially Grouted Riprap	2	4	2	5
Articulating Concrete Blocks	2	3	5	5
Grout-Filled Bags	1	4	1	5
Grout-Filled Mattresses	3	4	5	5
Gabions, Gabion Mattresses	1	3	2	5

SF= Shallow Pier, e.g. Spread Footing DF= Deep Footing

Factor S4: Inspection and Maintenance

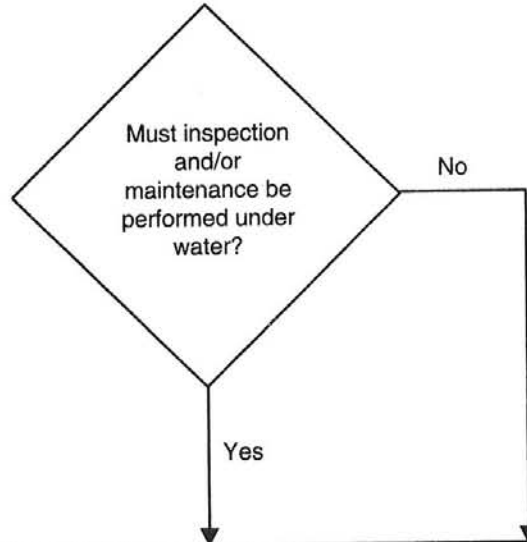

<u>Recommended values for S4</u>		
Riprap	5	5
Partially Grouted Riprap	4	5
Articulating Concrete Blocks	3	5
Grout-Filled Bags	2	5
Grout-Filled Mattresses	2	5
Gabions, Gabion Mattresses	1	5

APPENDIX D
RIPRAP INSPECTION RECORDING GUIDANCE

APPENDIX D

Riprap Inspection Recording Guidance

To guide the inspection of a riprap installation, a recording system is presented in this appendix. This guidance establishes numerical ratings from 0 (worst) to 9 (best). Recommended action items based on the numerical rating are also provided (Lagasse et al. 2006).

A single-digit code is used as indicated below to identify the current status of the rock riprap regarding its condition compared to the design intent, and the immediacy of need for maintenance activities to return it to the design condition.

This guidance covers riprap installations that may be: (1) located on stream banks for lateral stream stability purposes; (2) placed against bridge piers or abutments for protection against scour at the structure; (3) placed across the stream to provide vertical grade stabilization; or (4) other applications in riverine environments (e.g., guide banks or spurs).

Code Description

- U UNINSPECTABLE:
The riprap is uninspectable, due to burial by sediment, debris, or other circumstance. Until the condition of the riprap can be reliably determined, a plan of action should be developed that considers the degree of risk posed by potential failure of the installation.
- 9 THE RIPRAP INSTALLATION IS STABLE:
Riprap stones are angular to subangular with no evidence of deterioration or segregation of sizes; **and** the distribution of stone sizes and overall thickness of riprap layer conform to design specifications; **and** there is no evidence of displacement of individual stones.
- 8 THE RIPRAP INSTALLATION IS STABLE:
Riprap stones are angular to subangular with no evidence of deterioration or segregation of sizes; **and** the distribution of stone sizes and overall thickness of riprap layer conform to design specifications; **and** some displacement of individual stones is evident, but only smaller sized particles significantly smaller than the design d_{50} size have moved.
- 7 THE RIPRAP INSTALLATION IS STABLE:
Evidence of some deterioration of stones due to surficial weathering (abrasion, freeze-thaw or wet-dry spalling); **and** stone shape is primarily subangular.
OR
A minor decrease in overall layer thickness is evident, and/or particle displacement noted with displaced particles approaching the design d_{50} size; **and** the geotextile or granular filter has NOT been exposed.
- 6 THE RIPRAP INSTALLATION HAS EXPERIENCED EROSION:
Individual stones are primarily subrounded in shape due to surficial weathering; **and** the distribution of stone sizes still exhibits a d_{50} particle greater than the minimum allowable d_{50} size.
OR

Minor decrease in overall layer thickness is evident; **and** some particles greater than the design d_{50} size have been displaced; **and** the geotextile or granular filter has NOT been exposed.

- 5 THE RIPRAP INSTALLATION HAS EXPERIENCED EROSION:
Similar condition as Code 6, except that the geotextile or granular filter has been exposed in local areas, or around the periphery of the installation. The inspector should attempt to identify whether stone displacement has occurred due to gravity slump or slide, or by hydraulic forces.
- 4 THE RIPRAP INSTALLATION HAS EXPERIENCED SIGNIFICANT EROSION:
Individual stones are subrounded to rounded in shape due to significant deterioration, **and** the distribution of stone sizes exhibits a d_{50} particle smaller than the minimum allowable d_{50} size.
OR
Significant decrease in overall layer thickness is evident in local areas; **and** some particles greater than the design d_{50} size have been displaced; **and** the geotextile or granular filter has been exposed in local areas.
- 3 THE RIPRAP INSTALLATION IS UNSTABLE:
The riprap matrix consists primarily of stones smaller than the minimum allowable d_{50} particle size; **and** the overall layer thickness is less than 50% of specification.
OR
A significant portion of the particles greater than the design d_{50} size has been displaced, **and** the geotextile or granular filter has been exposed over more than 20% of the installation area.
- 2 THE RIPRAP INSTALLATION IS UNSTABLE:
The riprap matrix consists almost entirely of stones smaller than the minimum allowable d_{50} particle size; **and** the overall layer thickness is less than 2 particles thick.
OR
Most of the particles greater than the design d_{50} size has been displaced, **and** the geotextile or granular filter has been exposed over more than 50% of the installation area.
- 1 THE RIPRAP INSTALLATION IS ERODED AND CAN NO LONGER SERVE ITS FUNCTION. IMMEDIATE MAINTENANCE IS REQUIRED:
Most of the riprap matrix has been displaced or is missing; **and** native subgrade soil is exposed.
OR
Large patches or voids in the riprap matrix have been opened; **and** stones are no longer in contact with structural elements.
- 0 THE RIPRAP INSTALLATION IS ESSENTIALLY GONE AND SCOUR IS IMMINENT. IMMEDIATE MAINTENANCE IS REQUIRED:
The riprap has deteriorated to the point that it cannot perform its protective function even in minor events.

Particle Size Distribution. During inspection, the existing particle size distribution should be determined and compared with the design particle size distribution to assess whether the riprap particles have deteriorated over time. NCHRP Report 568 (Lagasse et al. 2006) and Design Guideline 4 provide guidance for determining particle size distribution in the field.

Recommended action.

Code U: The riprap cannot be inspected. A plan of action should be developed to determine the condition of the installation. Possible remedies may include: removal of debris, excavation during low flow, probing, or nondestructive testing using ground penetrating radar or seismic methods.

Codes 9, 8, or 7: Continue periodic inspection program at the specified interval.

Codes 6, 5, or 4: Increase inspection frequency. The rating history of the installation should be tracked to determine if a downward trend in the rating is evident. Depending on the nature of the riprap application, the installation of monitoring instruments might be considered.

Codes 3 or 2: The Maintenance Engineer's office should be notified and maintenance should be scheduled. The cause of the low rating should be determined, and consideration given to redesign and replacement. Materials other than standard riprap might be considered.

Code 1 or 0: The Maintenance Engineer's office should be notified immediately. Depending upon the nature of the riprap application, other local officials and/or law enforcement agencies may also need to be notified.

(page intentionally left blank)