

This document downloaded from  
**vulcanhammer.net**

since 1997,  
your source for engineering information  
for the deep foundation and marine  
construction industries, and the historical  
site for Vulcan Iron Works Inc.

Use subject to the “fine print” to the  
right.

Don't forget to visit our companion site <http://www.vulcanhammer.org>

All of the information, data and computer software ("information") presented on this web site is for general information only. While every effort will be made to insure its accuracy, this information should not be used or relied on for any specific application without independent, competent professional examination and verification of its accuracy, suitability and applicability by a licensed professional. Anyone making use of this information does so at his or her own risk and assumes any and all liability resulting from such use. The entire risk as to quality or usability of the information contained within is with the reader. In no event will this web page or webmaster be held liable, nor does this web page or its webmaster provide insurance against liability, for any damages including lost profits, lost savings or any other incidental or consequential damages arising from the use or inability to use the information contained within.

This site is not an official site of Prentice-Hall, the University of Tennessee at Chattanooga, Vulcan Foundation Equipment or Vulcan Iron Works Inc. (Tennessee Corporation). All references to sources of equipment, parts, service or repairs do not constitute an endorsement.

# ENCE 461

## Foundation Analysis and Design

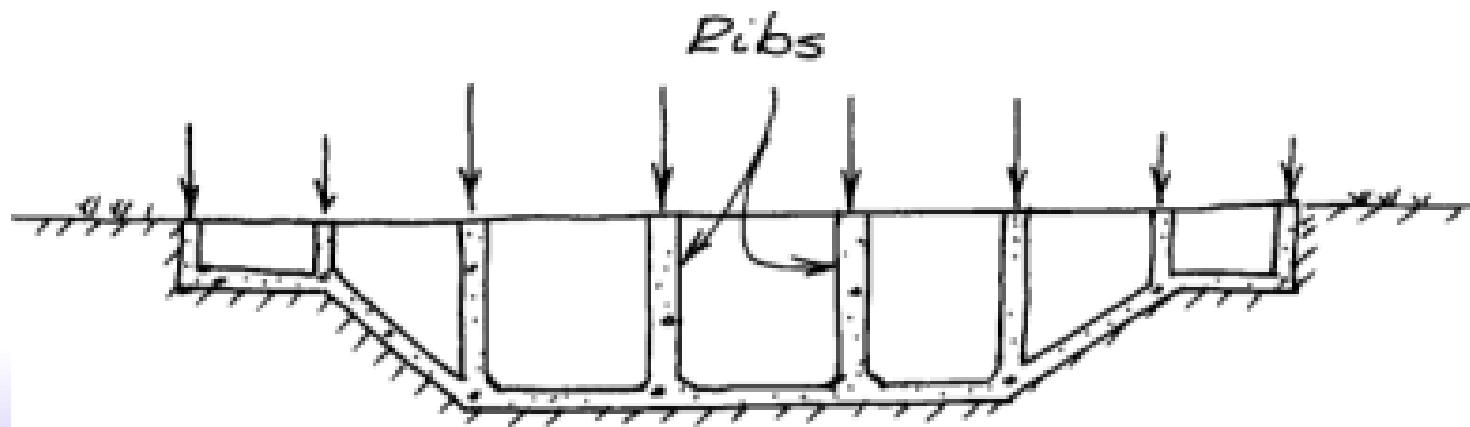

Waffle structure.  
(International Plaza)

Mat Foundations (Part II)

# Nonrigid Methods

- Nonrigid methods consider the deformation of the mat and their influence of bearing pressure distribution.
- These methods produce more accurate values of mat deformations and stresses
- These methods are more difficult to implement than rigid methods because of soil-structure interaction

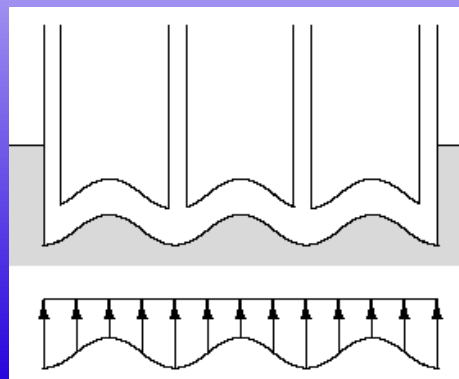

# Nonrigid Methods

- Coefficient of Subgrade Reaction
- Winkler Methods
- Coupled Method
- Pseudo-Coupled Method
- Multiple-Parameter Method
- Finite Element Method

# Coefficient of Subgrade Reaction

- Nonrigid methods must take into account that both the soil and the foundation have deformation characteristics.
- These deformation characteristics can be either linear or non-linear (especially in the case of the soils)
- The deformation characteristics of the soil are quantified in the coefficient of subgrade reaction, or subgrade modulus, which is similar to the modulus of elasticity for unidirectional deformation

# Coefficient of Subgrade Reaction

- Definition of Coefficient of Subgrade Reaction

$$k_s = \frac{q}{\delta}$$

- $k_s$  = coefficient of subgrade reaction, units of force/length<sup>3</sup> (not the same as unit weight!)
- $q$  = bearing pressure
- $\delta$  = settlement

# Coefficient of Subgrade Reaction

- Plate load test for coefficient of subgrade reaction

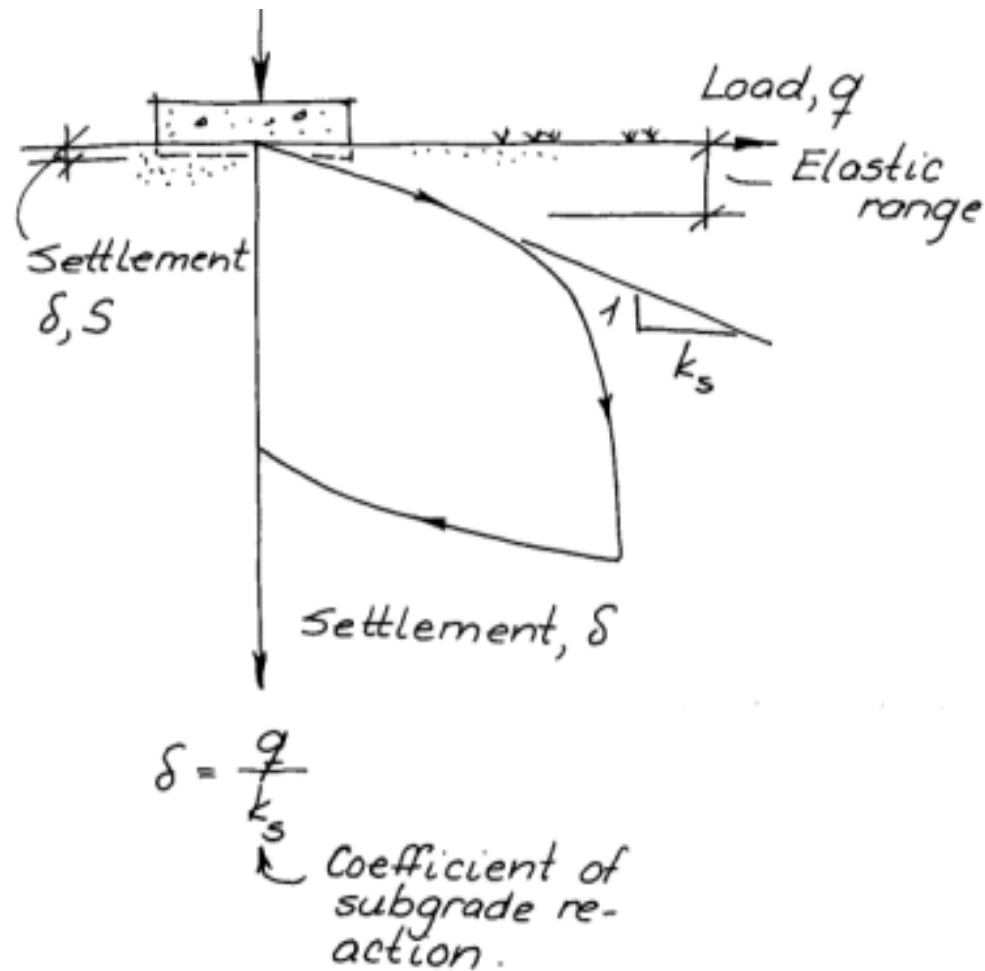

# Coefficient of Subgrade Reaction

- Application of coefficient of subgrade reaction to larger mats

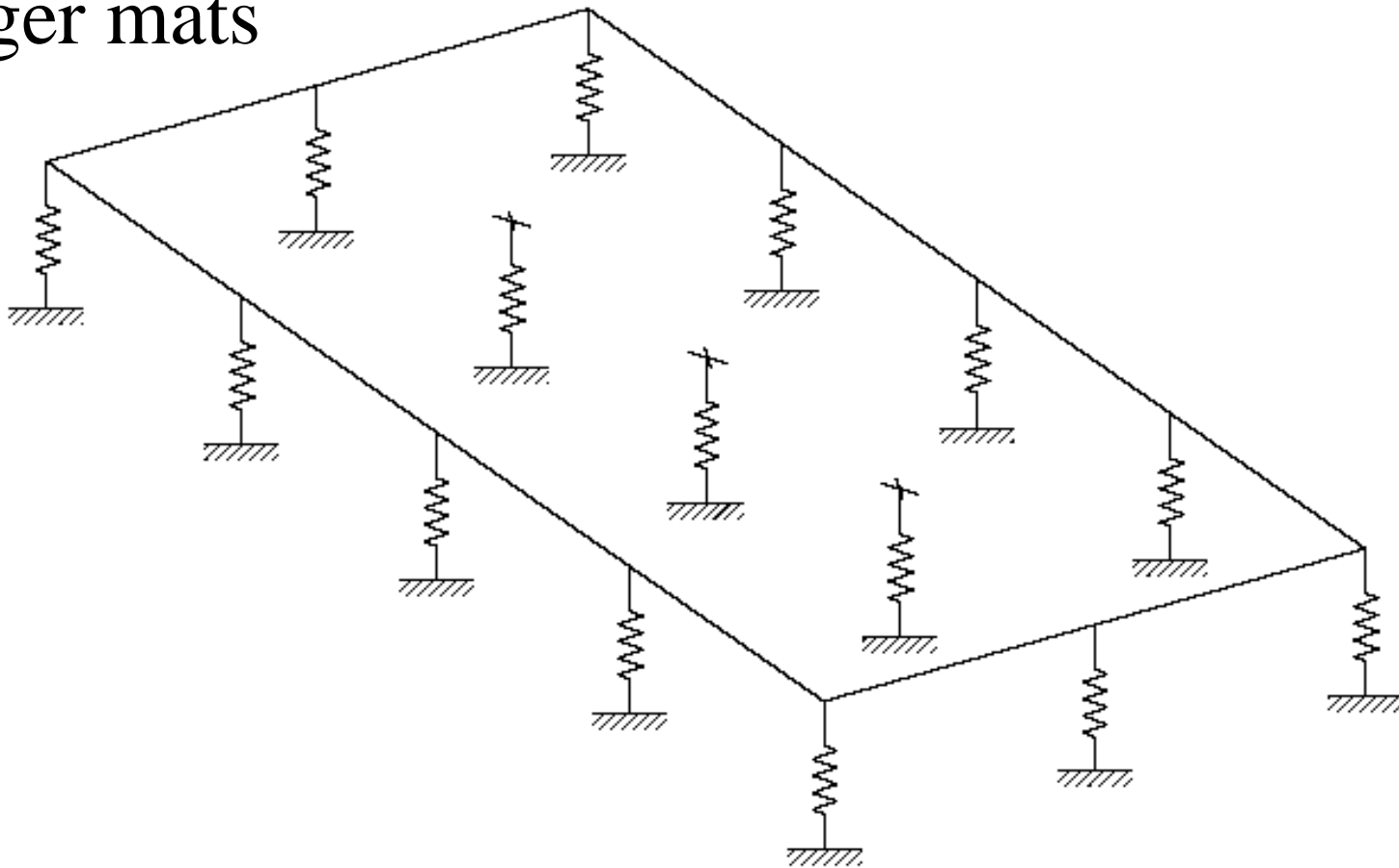

**Figure 10.6** The coefficient of subgrade reaction forms the basis for a “bed of springs” analogy to model the soil-structure interaction in mat foundations.

# Coefficient of Subgrade Reaction



Figure 10.6 The coefficient of subgrade reaction forms the basis for a "bed of springs" analogy to model the soil-structure interaction in mat foundations.

- Portions of the mat that experience more settlement produce more compression in the springs
- Sum of these springs must equal the applied structural loads plus the weight of the mat

$$\sum P + W_f - u_D = \int q dA = \int \delta k_s dA$$

# Winkler Methods

- The earliest use of these "springs" to represent the interaction between soil and foundation was done by Winkler in 1867; the model is thus referred to as the Winkler method
- The one-dimensional representation of this is a "beam on elastic foundation," thus sometimes it is called the "beam on elastic foundation" method
- Mat foundations represent a two-dimensional application of the Winkler method

# Beams on Elastic Foundations

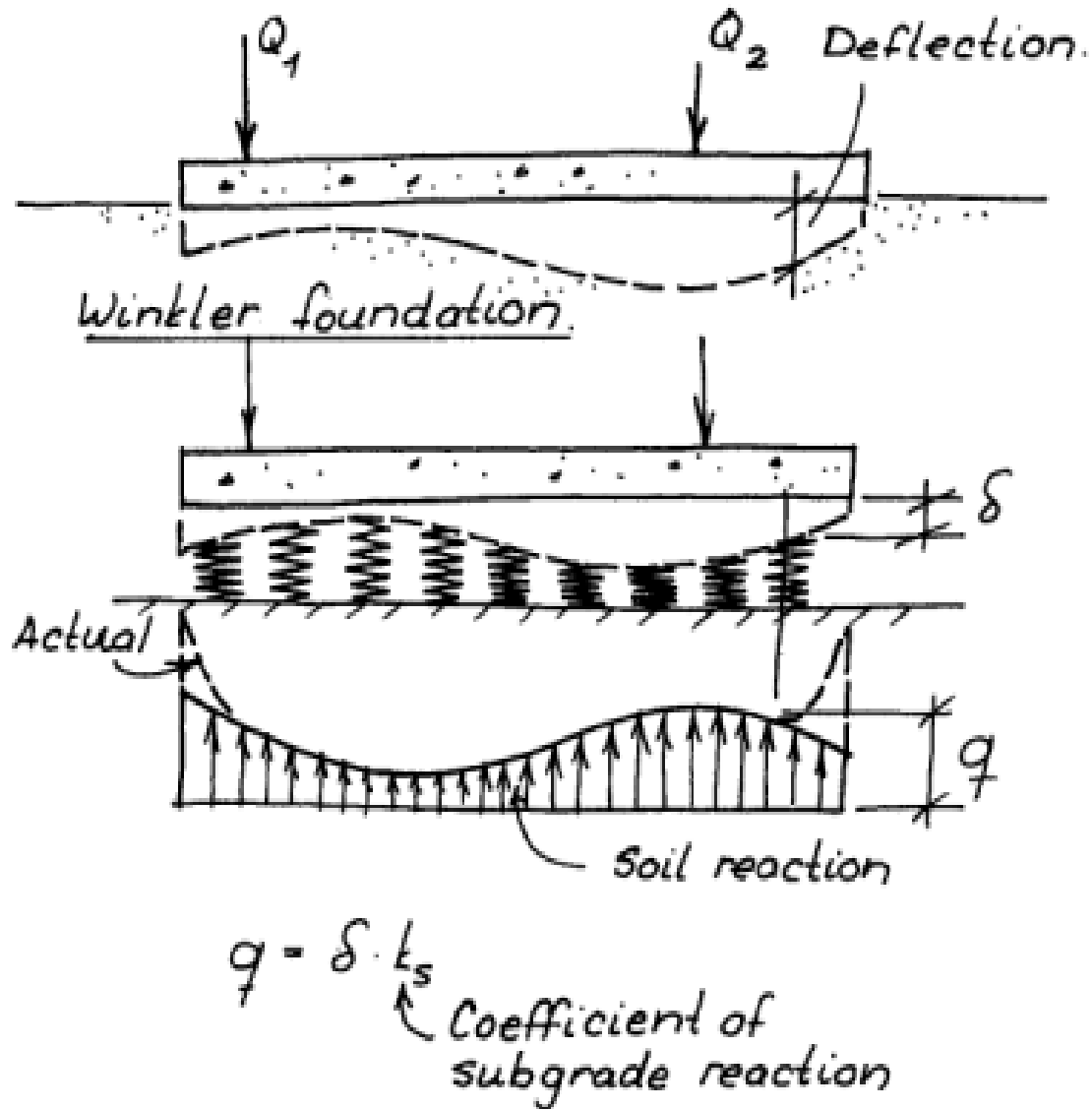

# Beams on Elastic Foundations

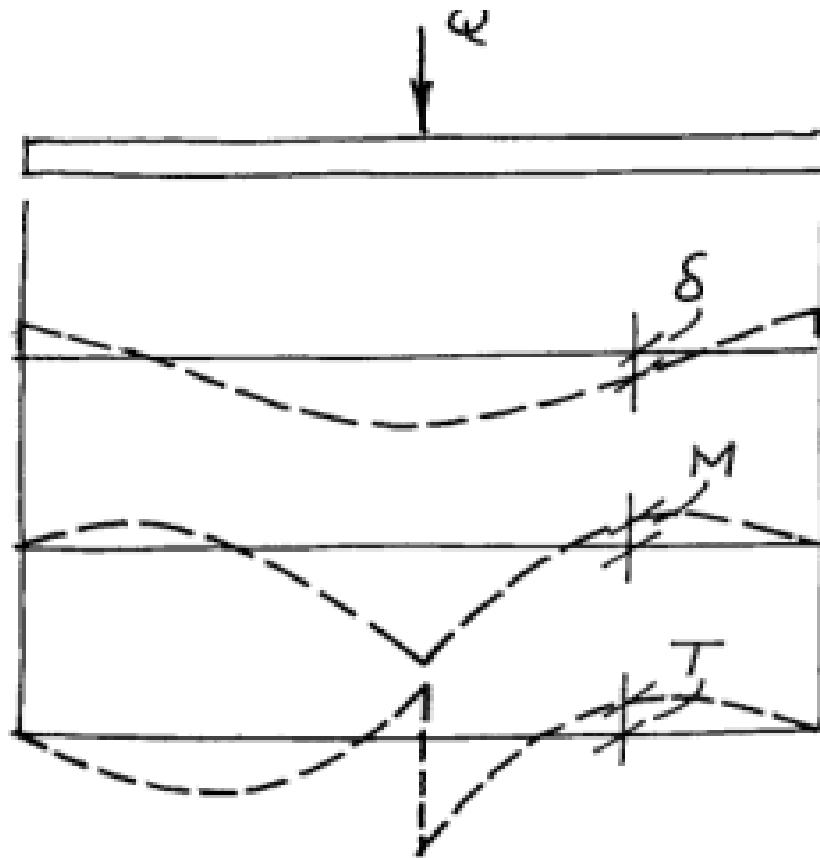

$\delta$ , deflection

$M$ , moment

$T$ , shear force

$$EI \frac{d^4 y}{dx^4} = q - - k_s B y$$

$$L L = \sqrt{\frac{k_s B L^4}{4 EI}}$$

# Beams on Elastic Foundations

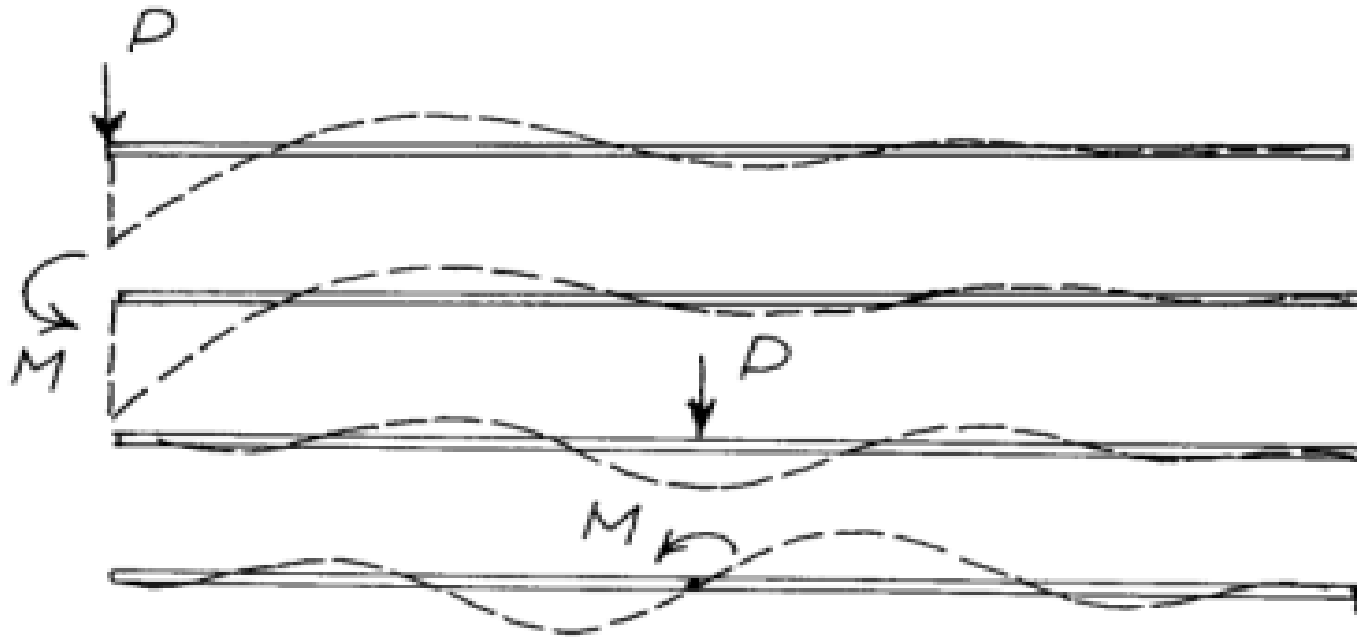

$$\Delta L = \frac{4}{\sqrt{\frac{k_3 B L^4}{4EI}}}$$

Shear force  
Moment  
Slope  
Deflection

# Application to Spread Footings

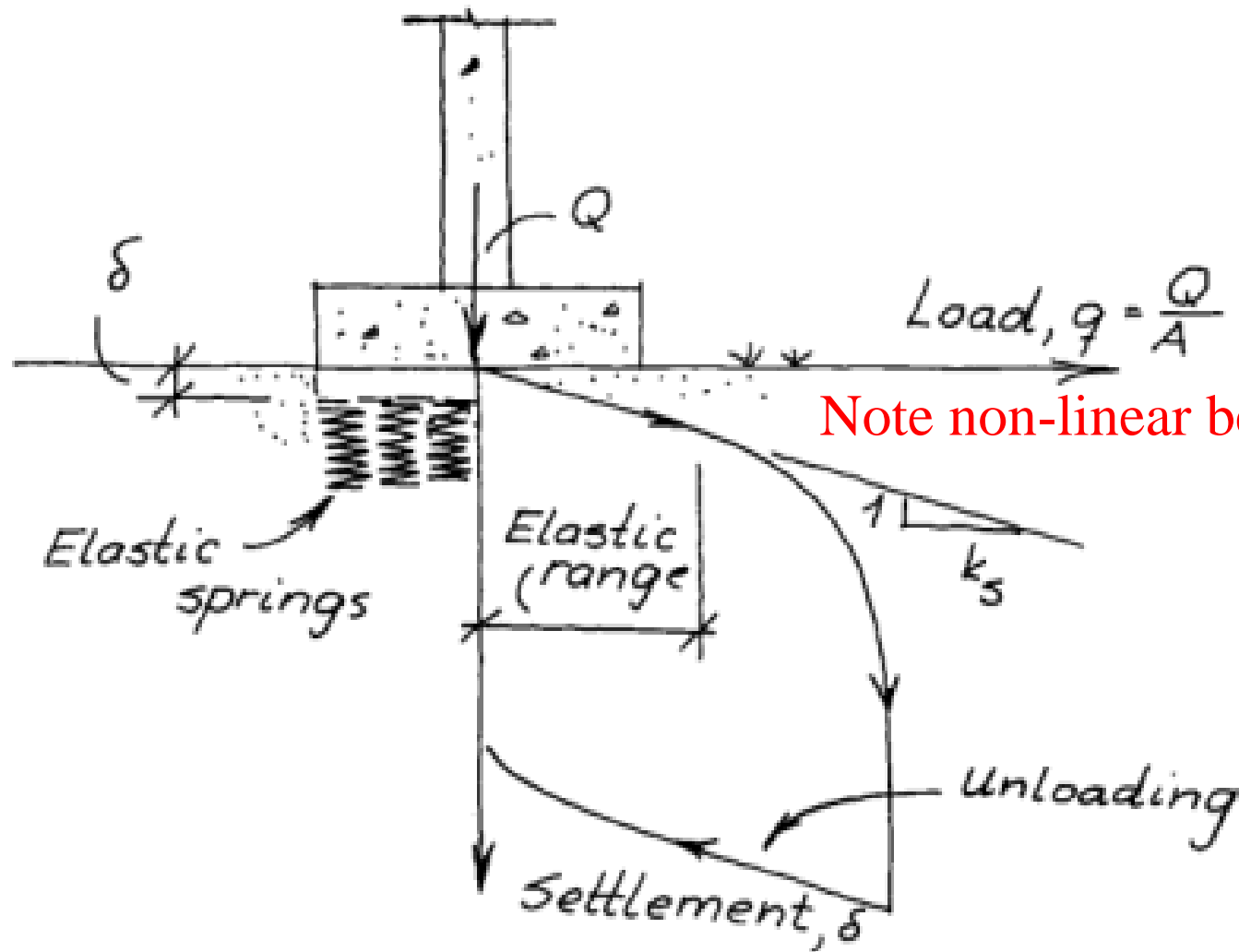

Note non-linear behaviour

$$\text{Settlement, } \delta = q/k_s$$

# Non-Linear Characteristics of Soil Deformation

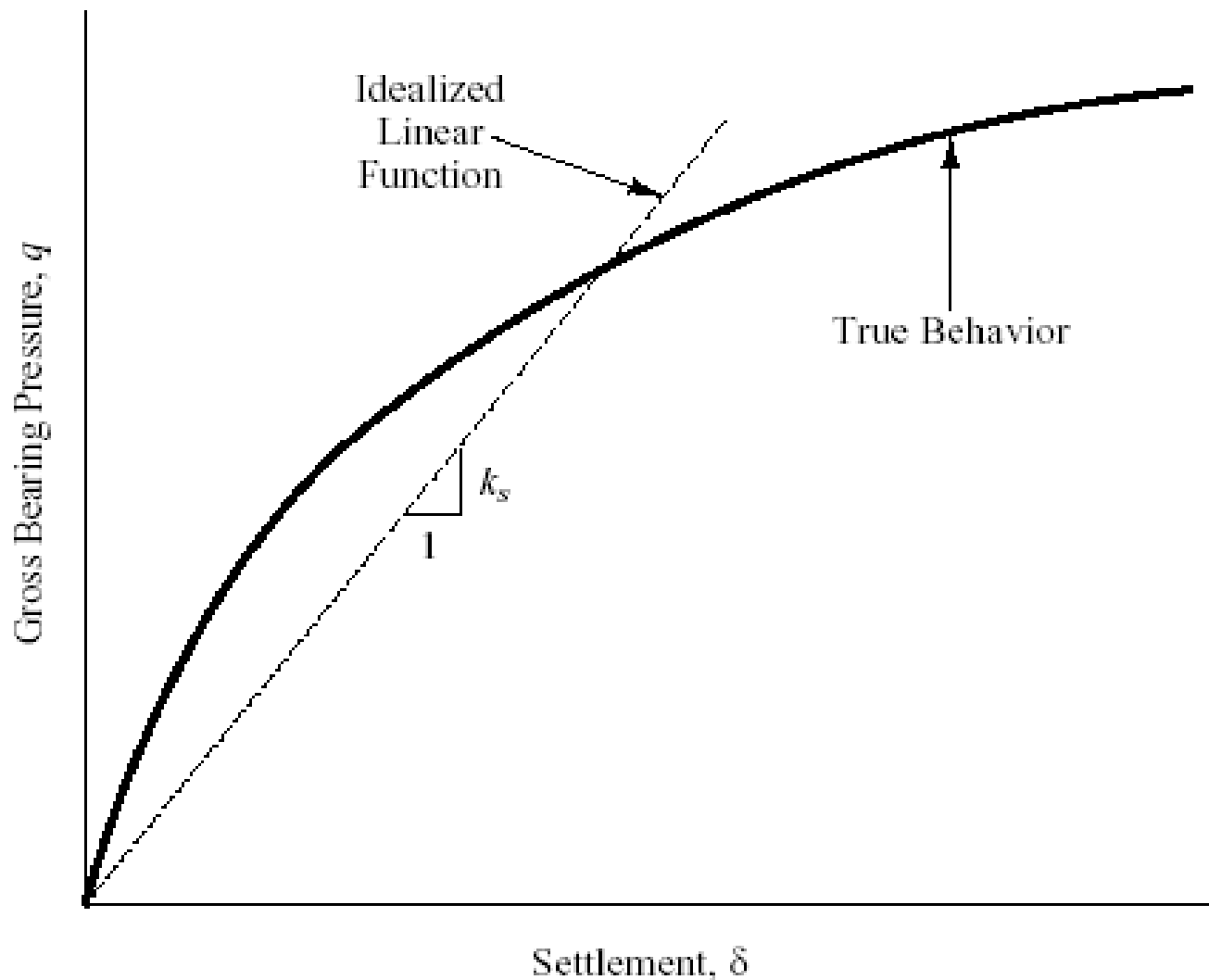

# Limitations of Winkler Method

- Load-settlement curves are not really linear; we must make a linear approximation to use the Winkler model
- Winkler model assumes that a uniformly loaded mat underlain by a perfectly uniform soil will uniformly settle into the soil.
  - Actual data show that such a mat-soil interaction will deflect in the centre more than the edges
  - This is one reason why we use other methods (such as Schmertmann's) to determine settlement

# Limitations of Winkler Method

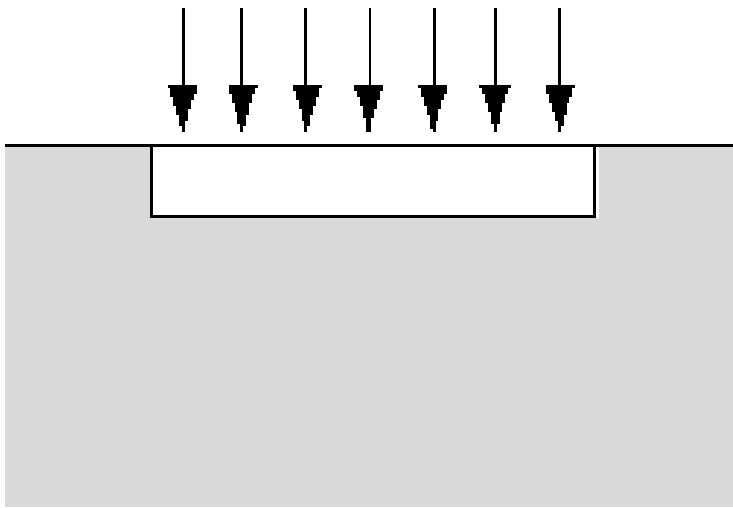

Per Winkler

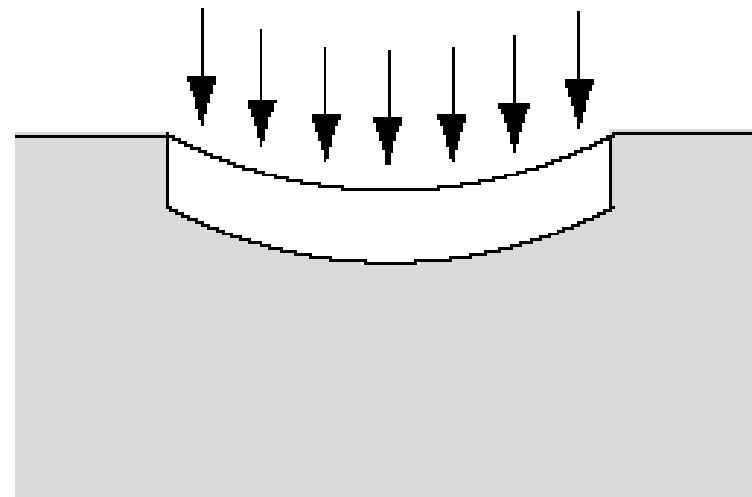

Actual

# Limitations of Winkler Method

- Soil springs do not act independently. Bearing pressure on one part of the mat influences both the "spring" under it and those surrounding it (due to lateral earth pressure)
- No single value of  $k_s$  truly represents the interaction between the soil and the mat
- The independent spring problem is in reality the largest problem with the Winkler model

# Coupled Method

- Ideally the coupled method, which uses additional springs as shown below, is more accurate than the Winkler method
- The problem with the coupled method comes in selecting the values of  $k_s$  for the coupling springs

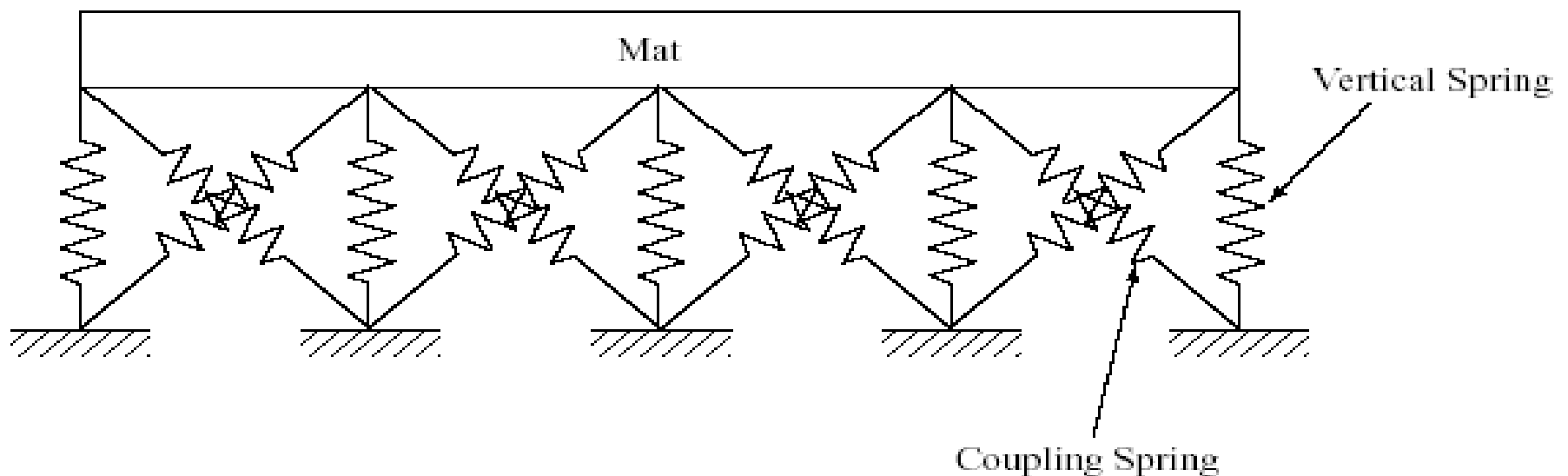

# Pseudo-Coupled Method

- An attempt to overcome both the lack of coupling in the Winkler method and the difficulties of the coupling springs
- Does so by using springs that act independently (like Winkler springs), but have different  $k_s$  values depending upon their location on the mat
- Most commercial mat design software uses the Winkler method; thus, pseudo-coupled methods can be used with these packages for more conservative and accurate results

# Pseudo-Coupled Method

- Implementation
  - Divide the mat into two or more concentric zones
    - The innermost zone should be about half as wide and half as long as the mat
  - Assign a  $k_s$  value to each zone
    - These should progressively increase from the centre
    - The outermost zone  $k_s$  should be about twice as large as the innermost zone
  - Evaluate the shears, moments and deformations using the Winkler method
  - Adjust mat thickness and reinforcement to satisfy strength and serviceability requirements

# Pseudo-Coupled Method

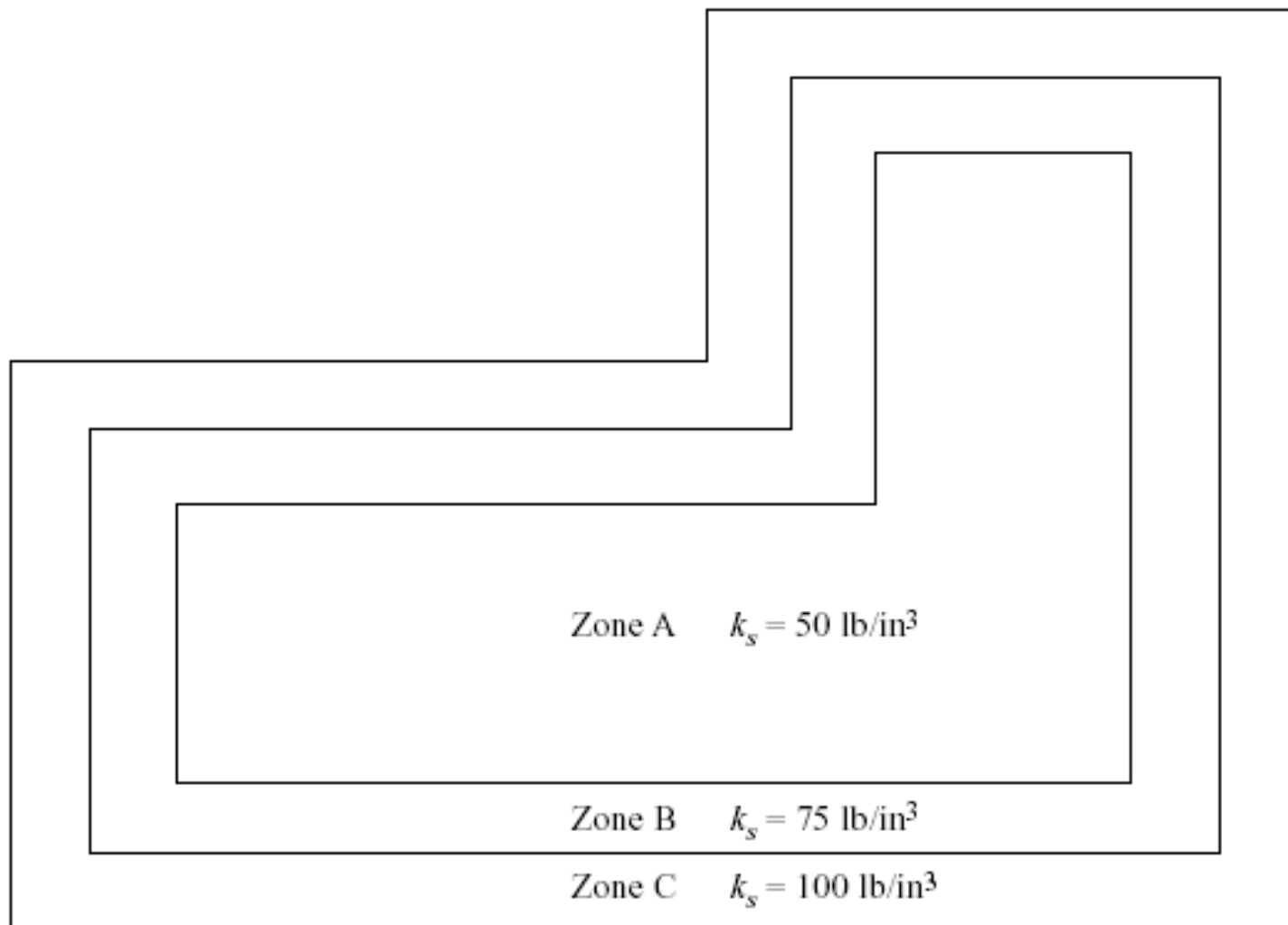

**Figure 10.10** A typical mat divided into zones for a pseudo-coupled analysis. The coefficient of subgrade reaction,  $k_s$ , progressively increases from the innermost zone to the outermost zone.

# Multiple-Parameter Method

- This method replaces the independently-acting linear springs of the Winkler method with springs and other mechanical elements
  - The additional elements define the coupling effects
- Method bypasses the guesswork involved in distributing the  $k_s$  values in the pseudo-coupled method; should be more accurate
- Method has not been implemented into software packages and thus is not routinely used on design projects

# Finite Element Method

- Models the entire soil-mat system in a three-dimensional way
- In theory, should be the most accurate method
- Method is not yet practical because
  - Requires large amount of computing power to perform
  - Difficult to determine soil properties in such a way as to justify the precision of the analysis, especially when soil parameters are highly variable
- Will become more in use as these problems are addressed

# Finite Element Method

- Finite element method is used for structural analysis
- Mat is modelled in a similar way to other plate structures with springs connected at the nodes of the elements
- Mat is loaded with column loads, applied line loads, applied area loads, and mat weight
- Usually superstructure stiffness is not considered (conservative)
  - Can be done but is rarely performed in practice

# Finite Element Method

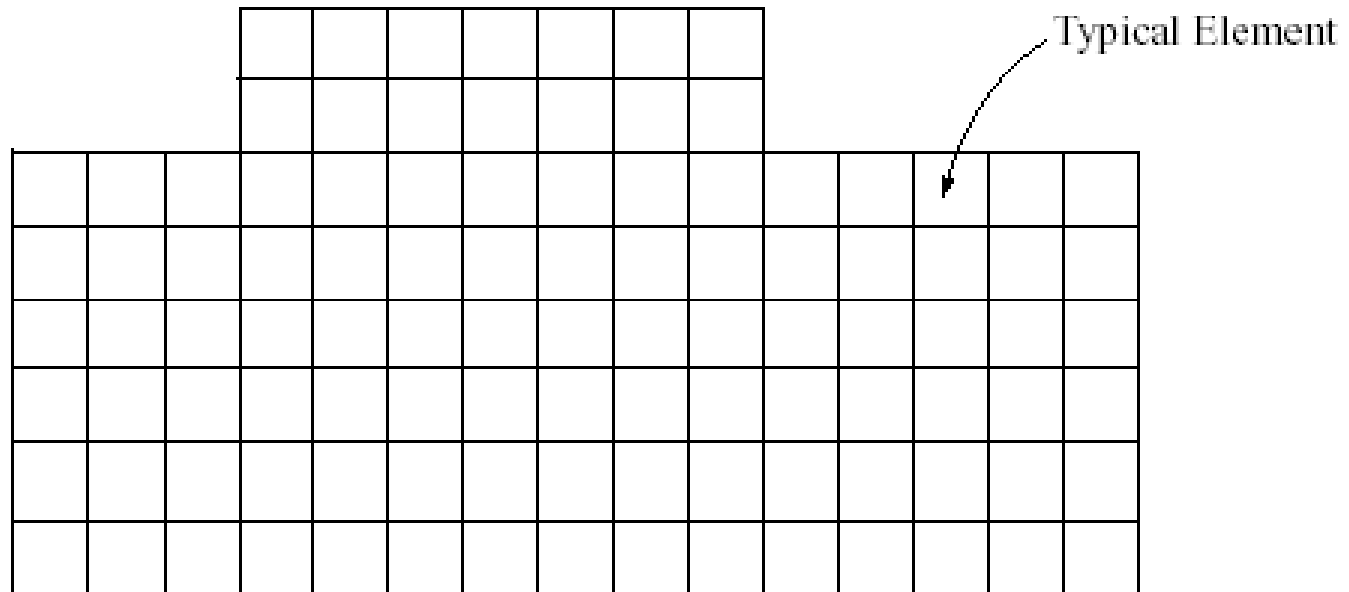

Plan

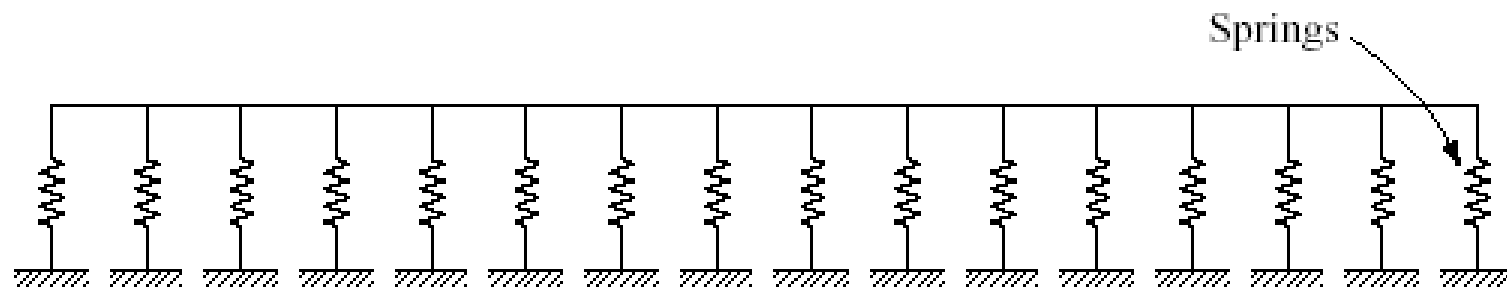

Profile

# Determining the Coefficient of Subgrade Reaction

- Not a straightforward process due to:
  - Width of the loaded area; wide mat will settle more than a narrow one because more soil is mobilised by a wide mat

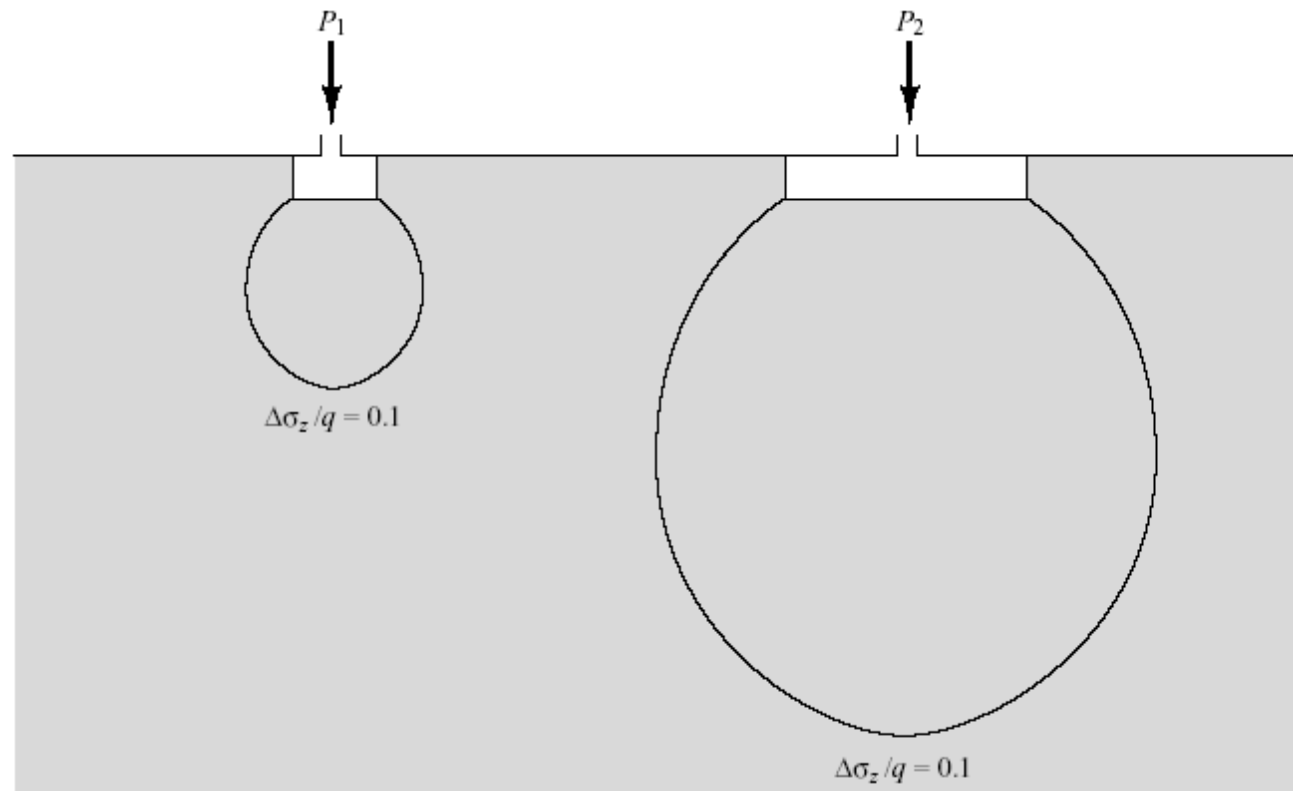

# Determining the Coefficient of Subgrade Reaction

- Not a straightforward process due to:
  - Shape of the loaded area: stresses beneath long, narrow loaded area is different from those below square loaded areas

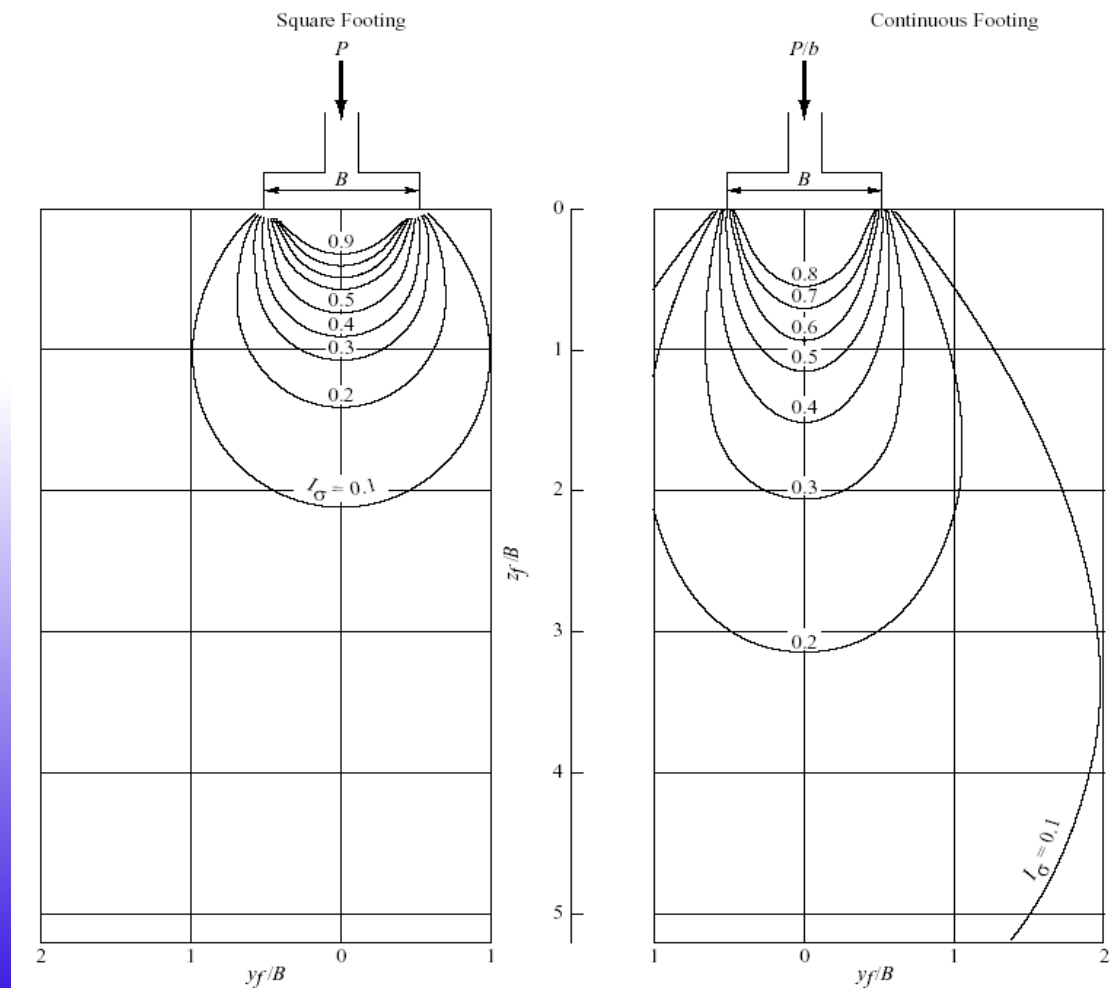

# Determining the Coefficient of Subgrade Reaction

- Not a straightforward process due to:
  - Depth of the loaded area below the ground surface
  - Change in stress in the soil due to  $q$  is a smaller percentage of the initial stress at greater depths

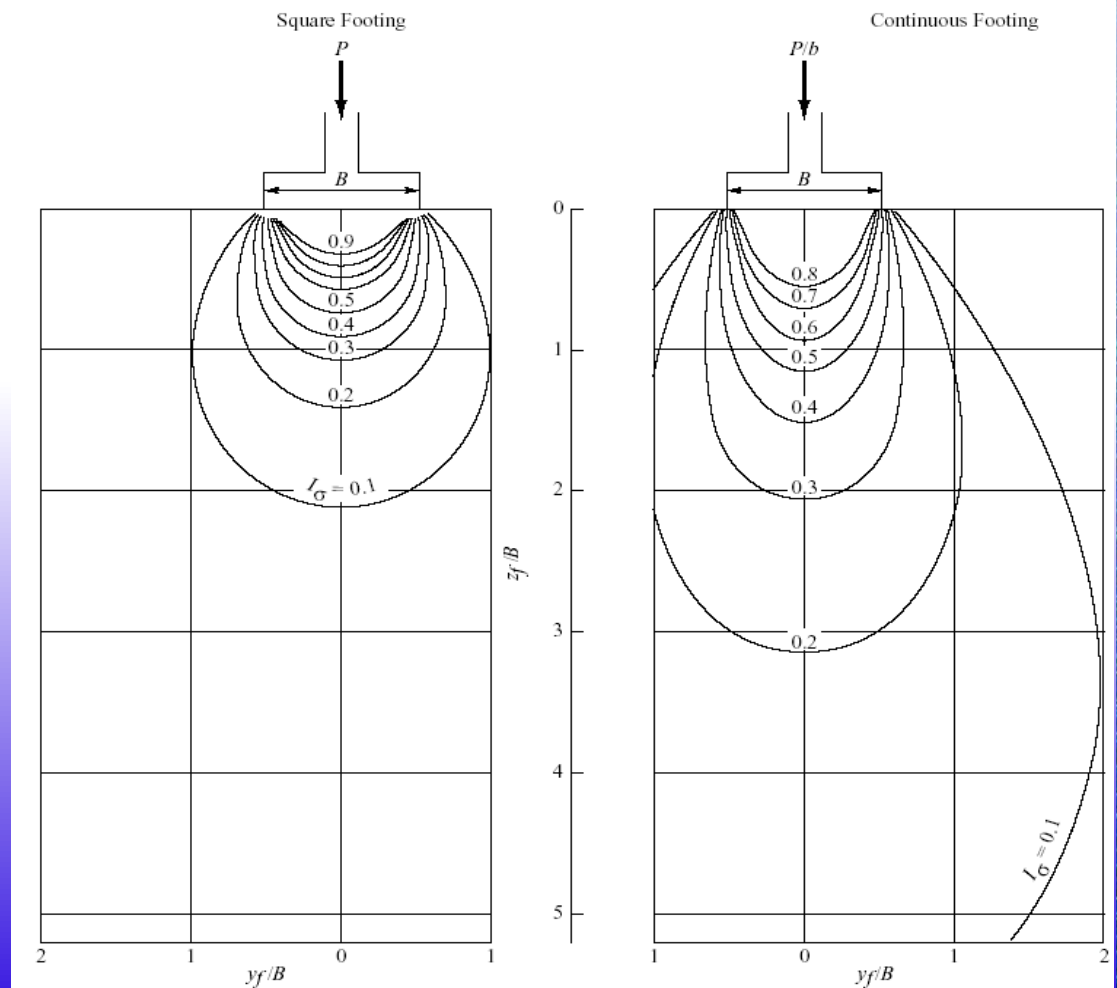

# Determining the Coefficient of Subgrade Reaction

- Not a straightforward process due to:
  - The position of the mat
    - To model the soil accurately,  $k_s$  needs to be larger near the edges of the mat and smaller near the centre
  - Time
    - With compressible (and especially cohesive compressible soils) mat settlement is a process which may take several years
    - May be necessary to consider both short and long term cases
  - Non-linear nature of soil deformation makes unique value of  $k_s$  non-existent

# Determining the Coefficient of Subgrade Reaction

- Methods used to determine coefficient
  - Plate load tests
    - Test results must be adjusted between the shape of the loading plate and the actual shape of the foundation
    - Adjustment must also be made for the size of the plate vs. the size of the foundation, and the influence of size on the depth of soil stress
    - Attempts to make accurate adjustments have not been very successful to date
  - Derived relationships between  $k_s$  and  $E_s$ 
    - Relationships developed are too limited in their application possibilities

# Determining the Coefficient of Subgrade Reaction

- Methods used to determine coefficient
  - Use settlement techniques such as Terzaghi's consolidation theory, Schmertmann's method, etc., and express the results in a  $k_s$  value
    - If using a pseudo-coupled value, use values of  $k_s$  in the centre of the mat which are half those along the perimeter
    - This methodology has the potential of eliminating the problems described earlier while at the same time yielding values of  $k_s$  which then can be used in a structural analysis of the mat with some degree of confidence

# Example of Determining Coefficient of Subgrade Reaction

- Given
  - Structure to be supported on a 30 m wide by 50 m long mat foundation
  - Average bearing pressure is 120 kPa
  - Average settlement determined  $\delta = 30$  mm using settlement analysis method
- Find
  - Design values of  $k_s$  used in a pseudo-coupled analysis

# Example of Determining Coefficient of Subgrade Reaction

- Solution
  - Compute average  $k_s$  for entire mat

$$k_s = \frac{q}{\delta}$$

$$k_s = \frac{120 \text{ kPa}}{0.030 \text{ m}} = 4000 \text{ kN / m}^2$$

# Example of Determining Coefficient of Subgrade Reaction

- Solution
  - Divide mat into three zones as shown

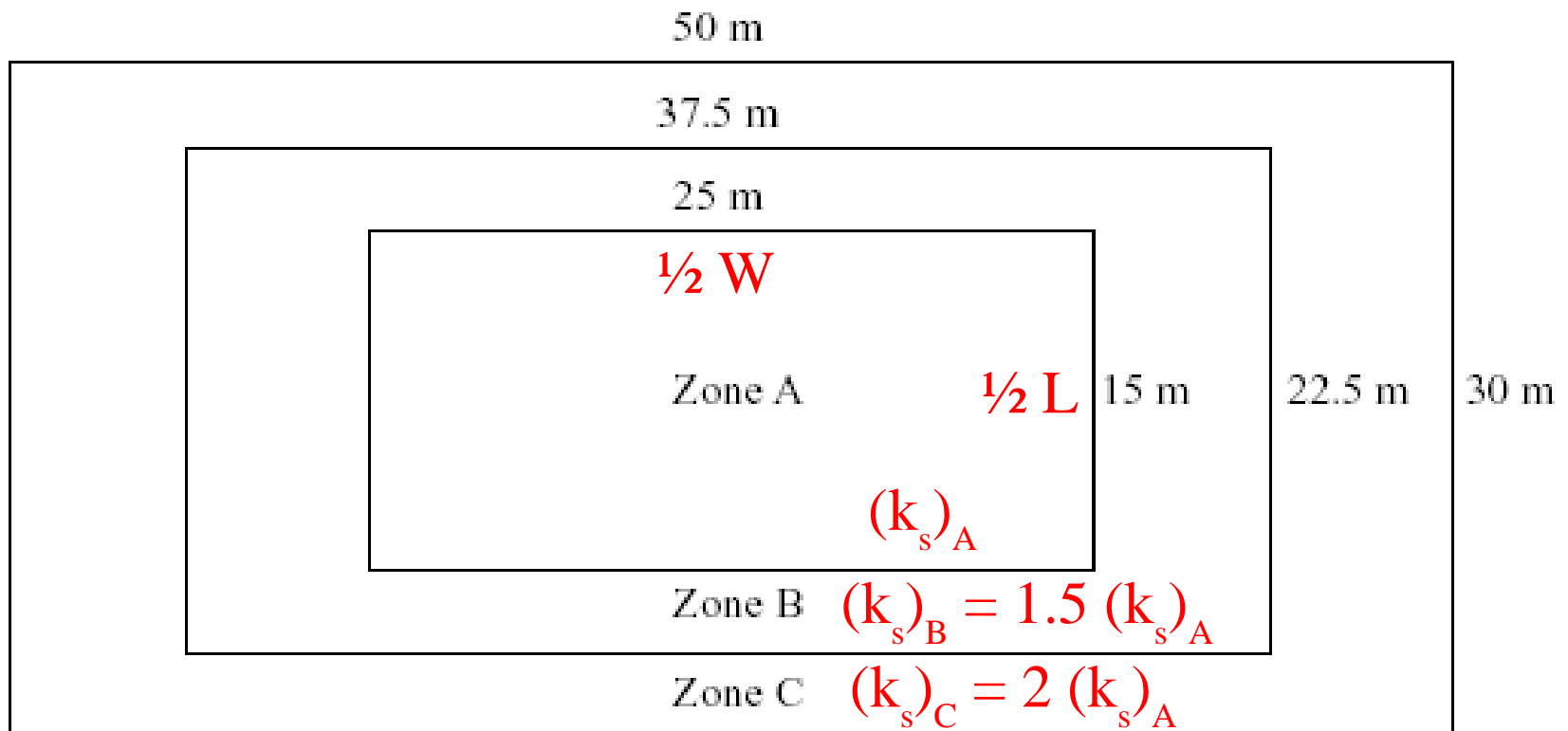

# Example of Determining Coefficient of Subgrade Reaction

- Solution

$$A_C = (50)(30) - 469 = 656 \text{ m}^2$$

- Compute the area of each zone

$$A_B = (37.5)(22.5) - 375 = 469 \text{ m}^2$$

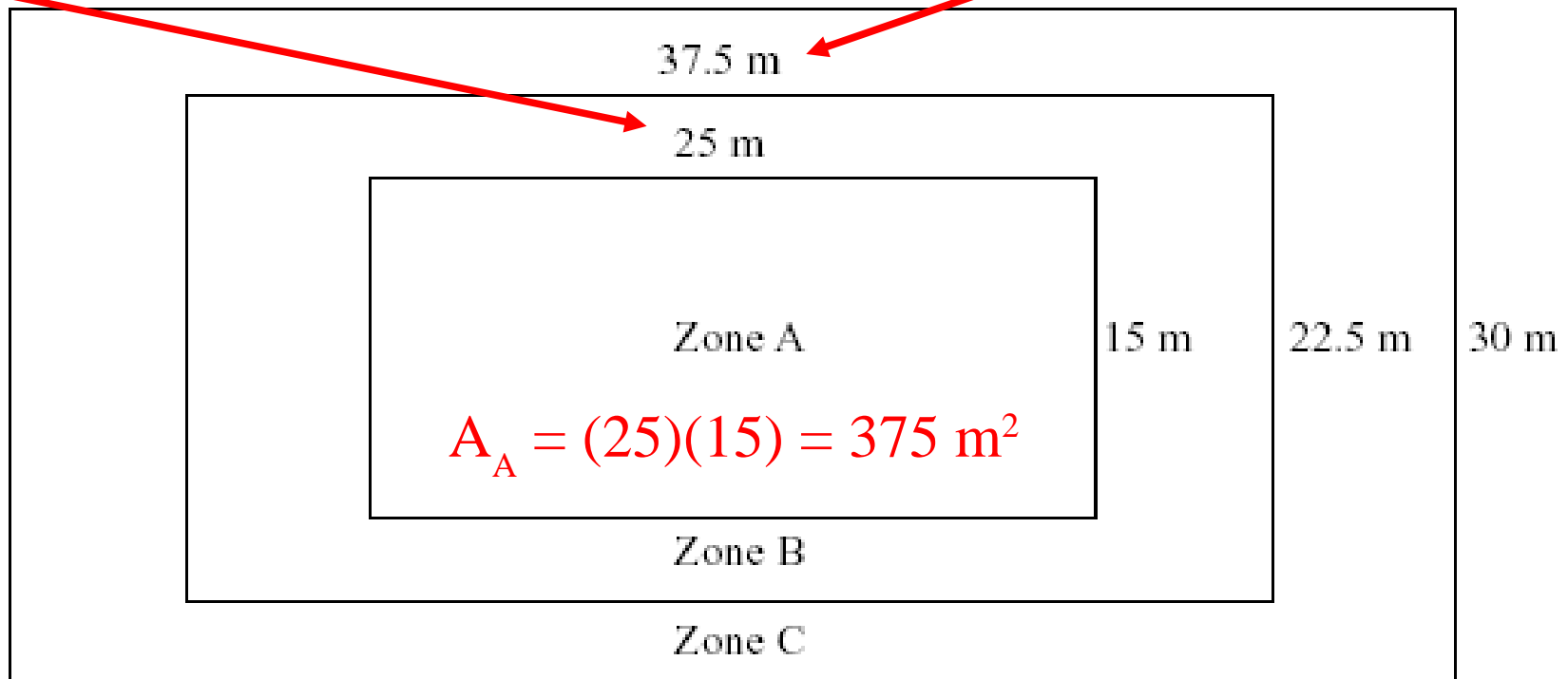

# Example of Determining Coefficient of Subgrade Reaction

- Solution

- Compute the design  $k_s$  values

$$A_A(k_s)_A + A_B(k_s)_B + A_C(k_s)_C = (A_A + A_B + A_C)(k_s)_{avg}$$
$$375(k_s)_A + (469)(1.5)(k_s)_A + (656)(2)(k_s)_A = 1500(k_s)_{avg}$$
$$2390(k_s)_A = 1500(k_s)_{avg}$$

$$(k_s)_A = 0.627(k_s)_{avg} \quad (k_s)_A = (0.627)(4000) = 2510 \text{ kN/m}^2$$

$$(k_s)_B = (0.627)(1.5)(4000) = 3765 \text{ kN/m}^3$$

$$(k_s)_C = (0.627)(2)(4000) = 5020 \text{ kN/m}^3$$

- ACI suggests varying  $k_s$  from  $\frac{1}{2}$  its computed value to 5 or 10 times the computed value, then base the structural design on the worst condition

# Structural Design of Mats

- Structural design requires two analyses
  - Strength
    - Evaluate these requirements using factored loads and LRFD design methods
    - Mat must have sufficient thickness  $T$  and reinforcement to safely resist these loads
    - $T$  should be large enough so that no shear reinforcement is required
  - Servicability
    - Evaluate using unfactored loads for excessive deformation at places of concentrated loads, such as columns, soil non-uniformities, mat non-uniformities, etc.
    - This is the equivalent of a differential settlement analysis
    - Mat must be made thicker if this is a problem

# Structural Design of Mats

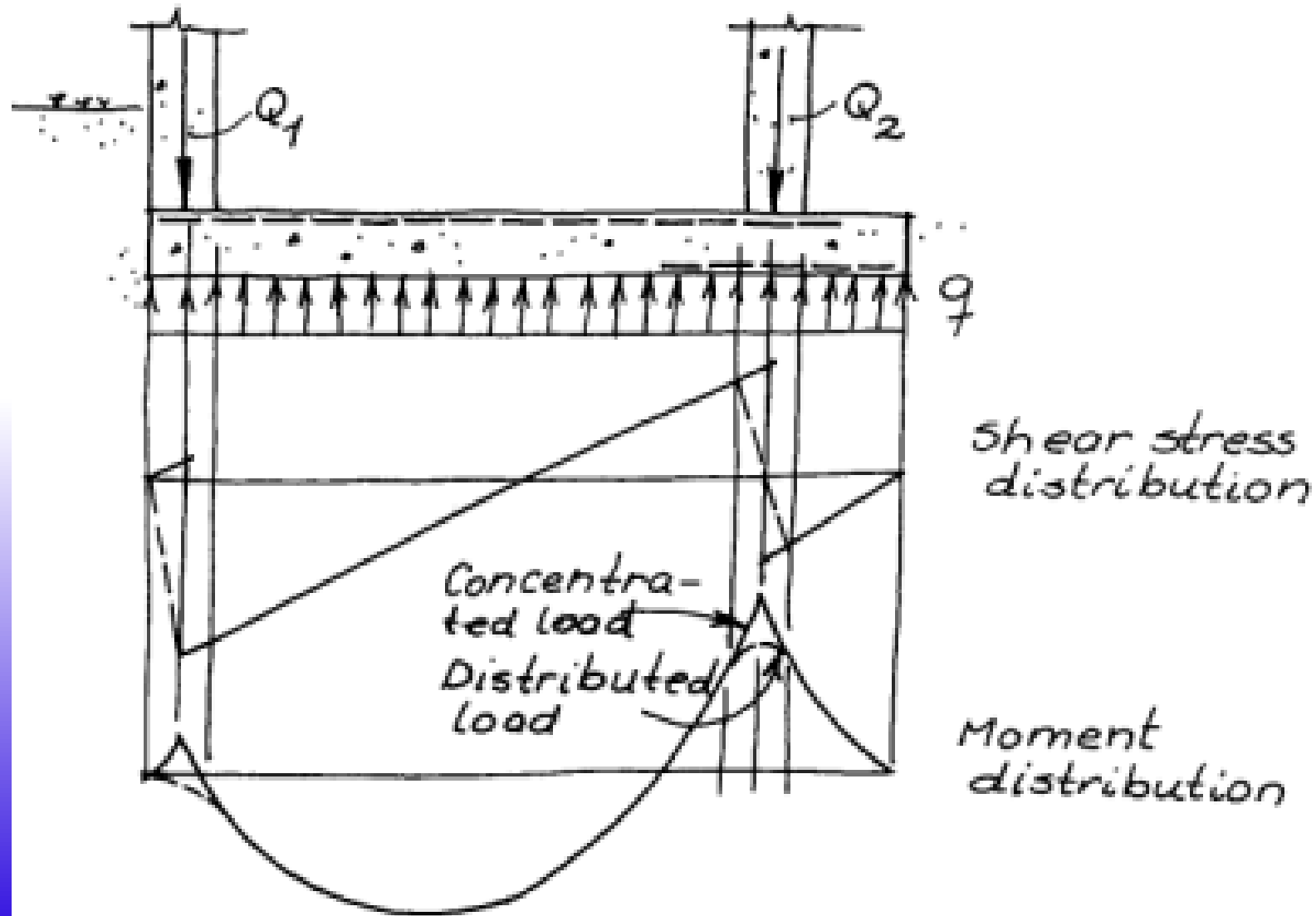

# Structural Design of Mats

Finite difference method.

$$\frac{\partial^4 w}{\partial x^4} + \frac{2 \partial^4 w}{\partial x^2 \partial x^2} + \frac{\partial^4 w}{\partial y^4} = \frac{q}{D} + \frac{D}{D(\partial_x \partial_y)}$$

Computer programs are available

Uncertainties:  $E_{\text{concrete}}, I_{\text{raft}}, k_s, E_s$

↑  
Coefficient of sub-grade reaction.

# Structural Design of Mats

- Closed form solutions
  - Once popular; however, with the advent of computers, have fallen out of favour
    - For example see <http://www.vulcanhammer.net/download/piletoe.pdf>
- Finite difference methods
- Finite element methods
  - Spring values as computed in the example can then be used in finite element analysis
  - The stiffer springs at the edges will encourage the foundation to sag in the centre, which is what we actually see in foundations

# Other Considerations in Mat Foundations

- Total settlement
  - "Bed of springs" solution should not be used to compute total settlement; this should be done using other methods
- Bearing capacity
  - Mat foundations generally do not have bearing capacity problems
  - With undrained silts and clays, bearing capacity needs to be watched
  - Methods for spread footings can be used with mat foundations, including presumptive bearing capacities

# Questions

